

Customer

Supplier

Company name
Editor
Phone number
E-mail

Fields of Application

Water supply systems.
Booster sets in high rise buildings and industry.
Water treatment.
Industrial washdown systems.
Fire extinguishing plants.
Boiler feed and condensate transfer.
Sanitary and cleaning installations.
For industrial applications and public services.
Water distribution services.
Industrial applications.
Shipbuilding, mining, power stations, filter units.
Irrigation plants.
Central heating systems.



Design Specification

The OMK Pump is a horizontal axis, radially split, ring section design multistage centrifugal pump of non-self priming type.

Impellers are between bearings, single entry, closed type and dynamically balanced. Impeller diameter will be corrected for optimal adherence to the required duty point.

The axial thrust is relieved by relieving boreholes in each impeller. The remaining thrust can be borne by large-sized bearings.

Pumps with exchangeable wear rings are available upon request.

The pump series consists of 5 sizes. OMK 32, 40, 50, 65 and 80. Stages are from 2 up to max. 14 stages.

Pump and motor are fitted on a common base plate and connected to each other via flexible coupling.

Normally, discharge part is at motor side on top, suction part is at dead end side on the right and rotation of direction is clockwise when viewed from driver.

Suction and discharge nozzles may be a choice of three 90° positions. By special request, it is possible to put the suction nozzle at the motor side. In this arrangement pump and motor rotation must be counter clockwise.

Technical Data

Suction Flanges	: DN50 - DN125 (PN25)
Discharge Flanges	: DN32 - DN80 (PN40)
Operating Pressure	: 40 bar
Flow Range	: 5 - 220 m ³ /h
Head Range	: 30 - 400 m
Temperature Range	: Up to 140 °C
Speed Range	: 1450 - 3600 rpm

Customer
Supplier

Company name
Editor
Phone number
E-mail

Operating data specification

Pumped fluid	Water		Rated flow	50	m ³ /h
Solids			Rated head	150	m
Kind			Geodetic head	0	m
Percentage of solid content	0		Available system NPSH		m
pH value			Inlet pressure (pin)	0	kPa
Temperature	20	°C	Altitude above sea level	100	m
Density	998.3	kg/m ³	Max. operating pressure	1330	kPa
Kin. viscosity	1.005	mm ² /s	Max. diff. pressure	1330	kPa
Vapour pressure	2.34	kPa			

Pump

Make	MAS DAF		Impeller type		
Pump type	OMK 50/ 3		Impeller construction		
Frame size			Impeller Ø		
Design			Max.	190	mm
Self priming	<input checked="" type="checkbox"/> No		designed	173	mm
Speed	2940	rpm	Min.	155	mm
Stages	3		Flow		
Suction port			Nominal	51.5	m ³ /h
Pressure rating	PN25		Max.	64.4	m ³ /h
Nominal pipe size	DN80		Min.	0	m ³ /h
Standard	DIN		Head		
Discharge port			Nominal	113	m
Pressure rating	PN40		Min.	99.1	m
Nominal pipe size	DN50		Max.	136	m
Standard	DIN		Shut off head	136	m
Shaft power	20.9	kW	NPSH3	2.71	m
Shaft power P2(Q=max.)	25.6	kW	Efficiency	69.5	%

Motor

Make/Type	22 KW-2900 RPM / 180M
Specific design	IE3 / 50 Hz / Pole pairs 1
Rated power	22 kW
Electric voltage	3~ 400 V
Speed	2950 rpm
Electric current	38 A
Frame size	180M
Degree of protection	IP 55
Type of protection	
Explosion protection	

Coupling

Make/Type	
Series	
Spacer length	mm
Frame size	

Materials

Pump		Shaft seal	Soft Packing
Pump Casing	GJL-250 (GG25)	Material code	
Impeller	GJL-250 (GG25)		
Shaft	A 276 Type 420 (X20Cr13)		
Bearing Housing	GJL-250 (GG25)		

Customer

Supplier

Company name
Editor
Phone number
E-mail

Power data referred to: Water; 20°C; 998.3kg/m³; 1.005mm²/s Sense of rotation Clockwise from the drive end

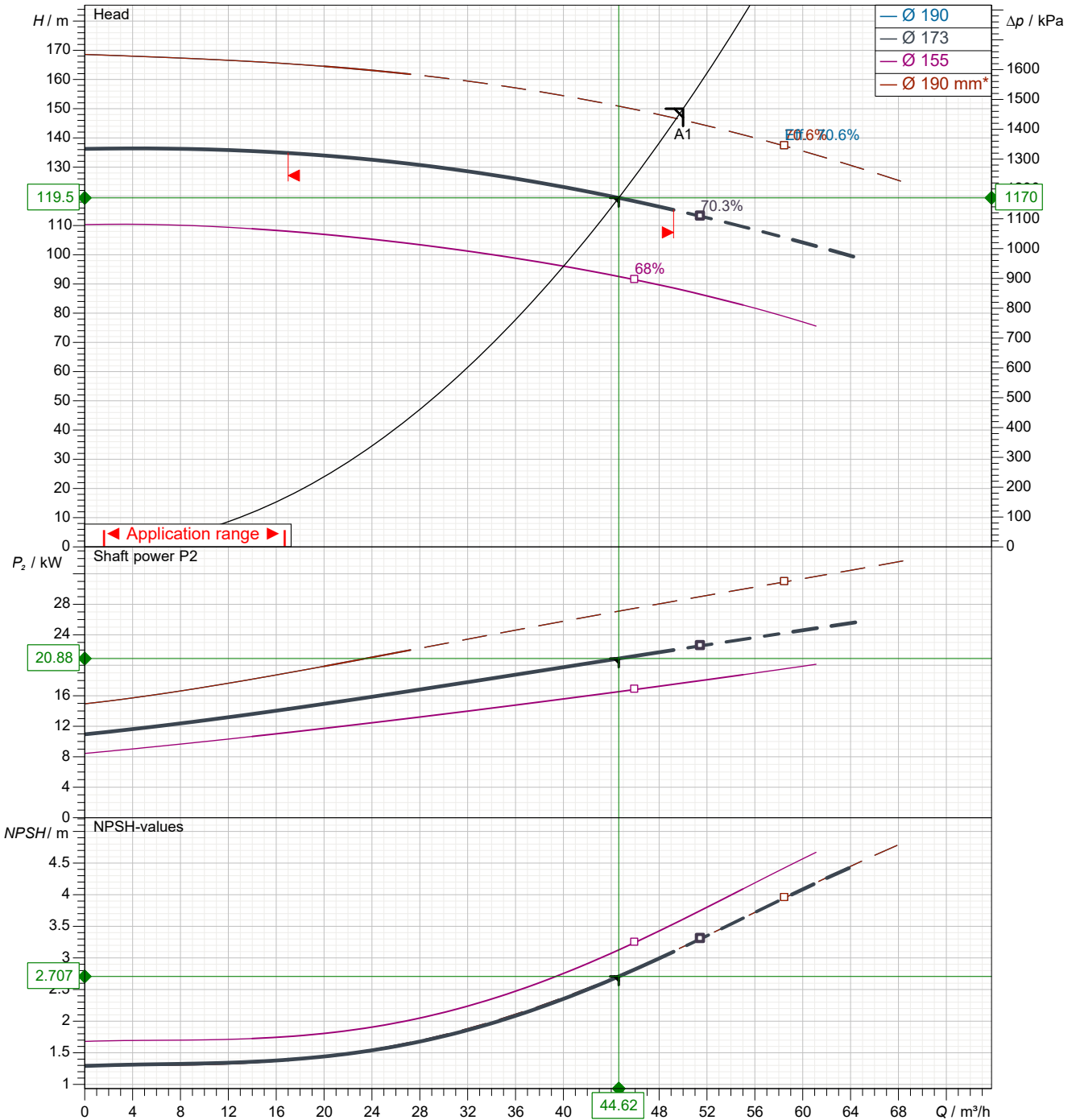

Pump curves in accordance with ISO 9906 2B

Pumped fluid	Water		Rated flow	50	m ³ /h
Temperature	20	°C	Rated head	150	m
Density	998.3	kg/m ³	Shaft power	20.9	kW
Kin. viscosity	1.005	mm ² /s	Speed	2940	rpm
Vapour pressure	2.34	kPa	NPSH3	2.71	m
Impeller Ø	173	mm	Efficiency	69.5	%

Subject to change

Projec

Issue date

Last update

2023-07-29

2023-07-29

Customer

Supplier

Company name
Editor
Phone number
E-mail

Performance curves

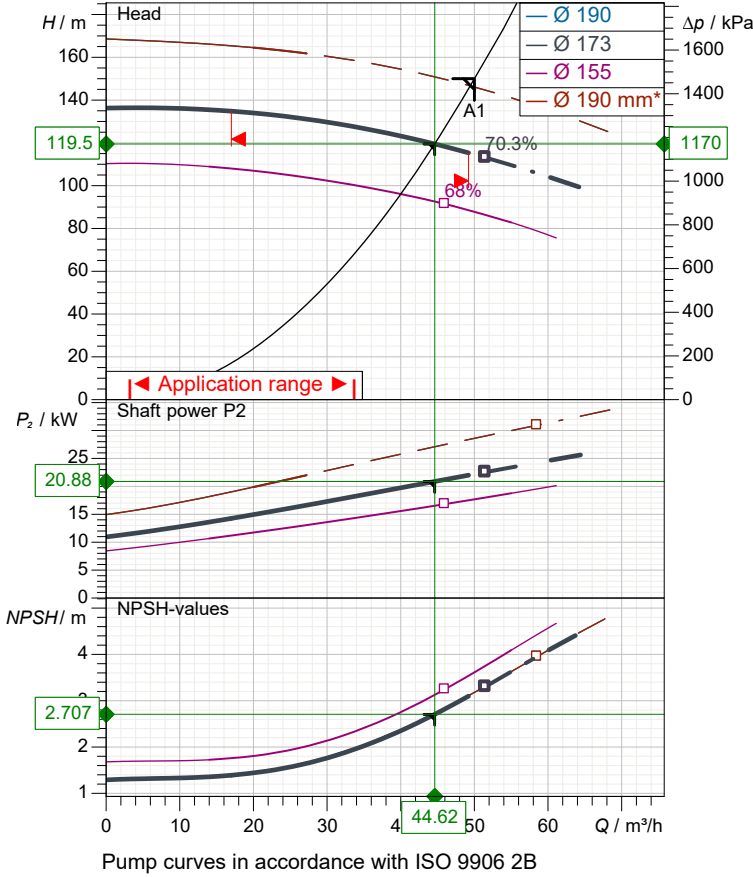

Pump

Make	MAS DAF
Pump type	OMK 50/ 3
Design	
Suction port	
Pressure rating	PN25
Nominal pipe size	DN80
Standard	DIN
Discharge port	
Pressure rating	PN40
Nominal pipe size	DN50
Standard	DIN

Operating data specification

Pumped fluid	Water	
Temperature	20	°C
Density	998.3	kg/m ³
Kin. viscosity	1.005	mm ² /s
Vapour pressure	2.34	kPa
Rated flow	50	m ³ /h
Rated head	150	m
Shaft power	20.9	kW
Speed	2940	rpm
NPSH3	2.71	m
Efficiency	69.5	%
Impeller Ø	173	mm

Motor

Make/Type	22 KW-2900 RPM / 180M
Specific design	IE3 / 50 Hz / Pole pairs 1
Rated power	22 kW
Speed	2950 rpm
Electric voltage	3~ 400 V
Electric current	38 A
Degree of protection	IP 55

Materials

Shaft seal	Soft Packing
Material code	

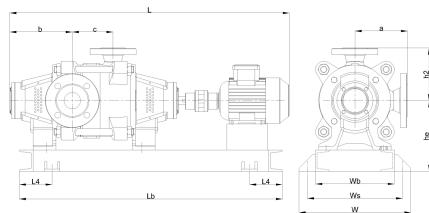

Dimensions	mm
a	210
b	223
c	266
h2	210
he	280
L	1480
L4	200
Lb	1400
w	480
wb	380
ws	430

Pump Casing	GJL-250 (GG25)
Impeller	GJL-250 (GG25)
Shaft	A 276 Type 420 (X20Cr13)
Bearing Housing	GJL-250 (GG25)

Customer

Supplier

Company name
Editor
Phone number
E-mail

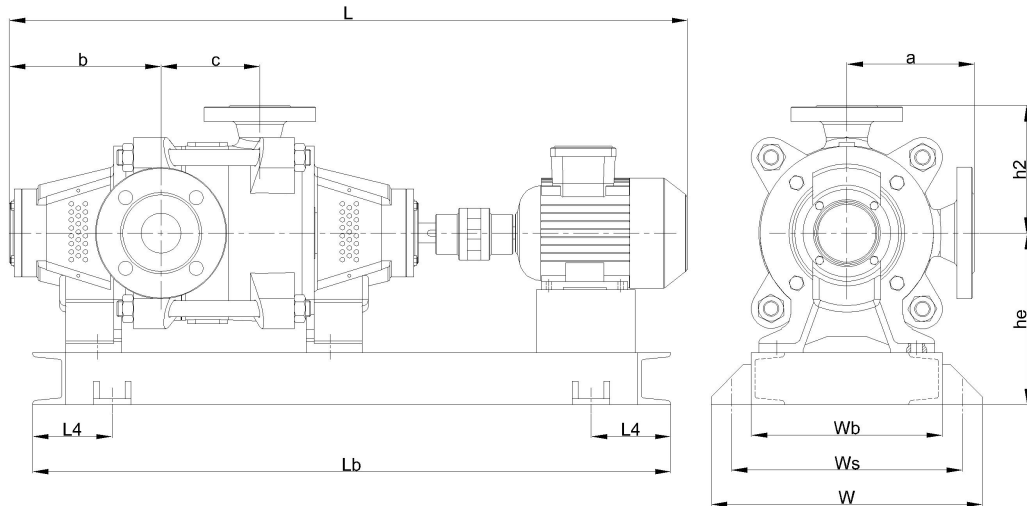

Dimensions	mm	Inlet / outlet	
a	210	Suction port	Discharge port
b	223	DN80	DN50
c	266	PN25	PN40
h2	210		
he	280		
L	1480		
L4	200		
Lb	1400		
w	480		
wb	380		
ws	430		

Customer

Supplier

Company name
Editor
Phone number
E-mail

motor data

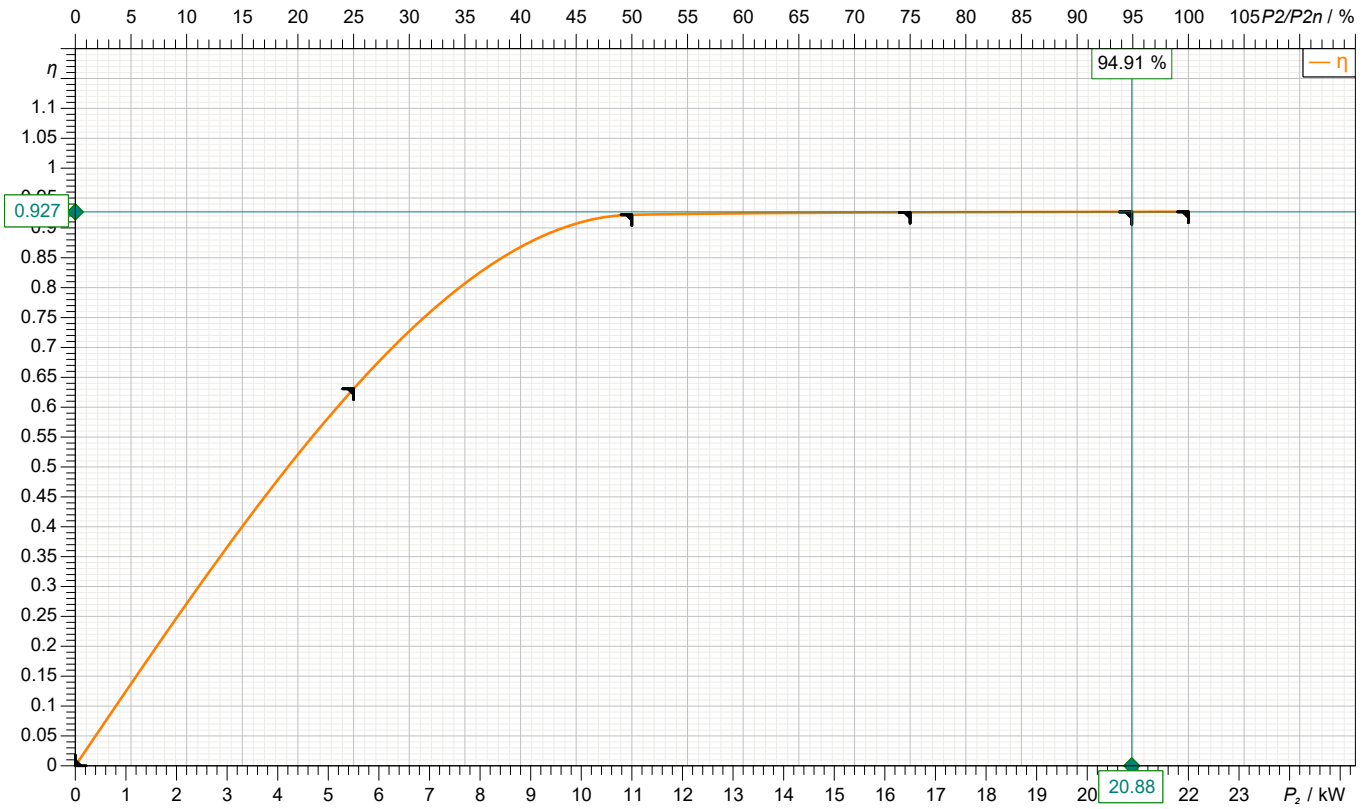

Symbol	No load	25 %	50 %	75 %	100 %	125 %
P_2 / kW	0	5.5	11	16.5	22	
P_i / kW		8.717	11.93	17.82	23.73	
η / %	0	63.09	92.2	92.6	92.7	

Motor

Make/Type	22 KW-2900 RPM / 180M	Degree of protection	IP 55
Specific design	IE3 / 50 Hz / Pole pairs 1	Type of protection	
Rated power	22 kW	Explosion protection	
Electric voltage	3~ 400 V	Service factor	1.15
Number of poles	2	Starting current	
Speed	2950 rpm	Starting torque	
Electric current	38 A	Moment of inertia	
Power factor	0.9	No. starts per hour	
Frame size	180M	Rated torque	71.2 Nm
Efficiency class	IE3	Insulation class	F (155C°)

Customer

Supplier

Company name
Editor
Phone number
E-mail

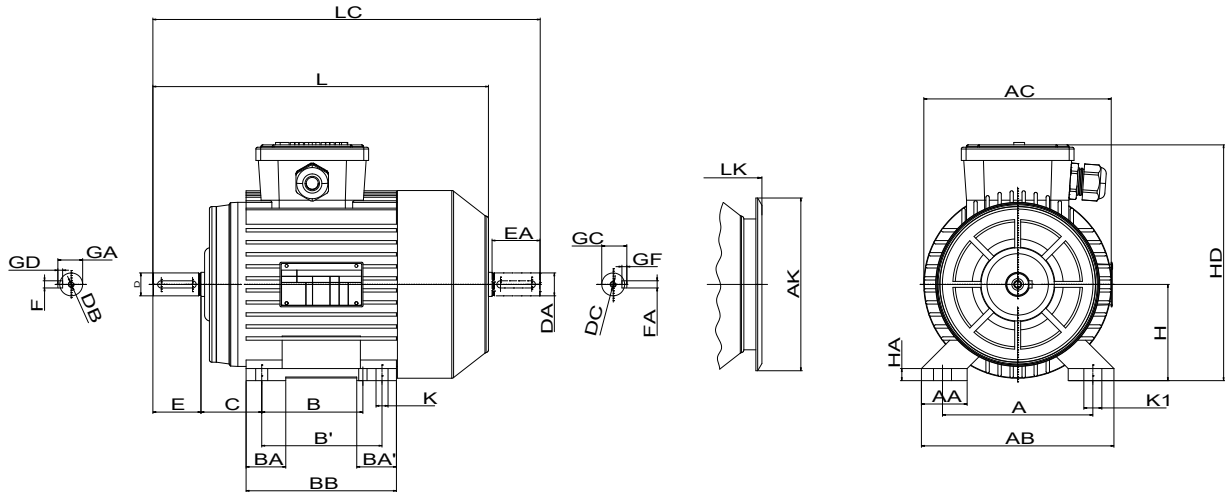

Dimensions	mm		
A	279	E	110
AA	68	EA	110
AB	354	FxGF	14X9
AC	348	FxGD	14X9
AK	303	GA	51.5
B	241	GC	51.5
B'	279	H	180
BA	57	HA	24
BA'	85	HD	421
BB	319	K	15
C	121	L	657
D	48	LC	773
DA	48	LK	714
DB	M16		
DC	M16		

Customer

Supplier

Company name
Editor
Phone number
E-mail

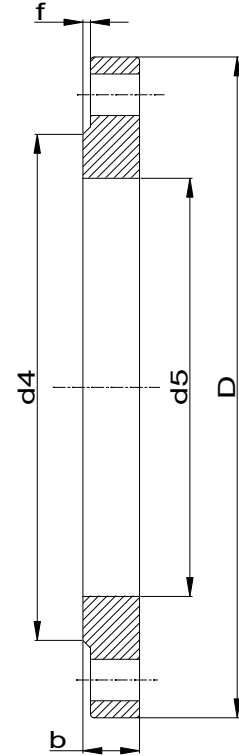
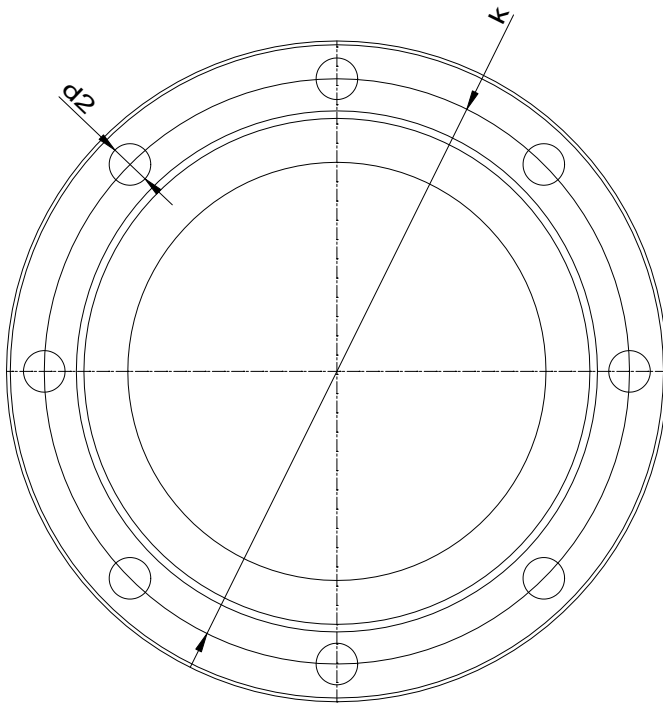

Suction connection

DN80
PN25

Discharge connection

DN50
PN40

Dimensions	mm
b	24
D	200
d2	18
d4	138
d5	90.5
DN	80
f	2
k	160
n	8

Dimensions	mm
b	20
D	165
d2	18
d4	102
d5	61.5
DN	50
f	2
k	125
n	4



Spare part list
OMK 50/ 3

Revision number

Page
9

Company name
Editor
Phone number
E-mail

Customer

Supplier

Subject to change

Projec

Issue date
2023-07-29

Last update
2023-07-29



Spare part list
OMK 50/ 3

Revision number

Page
10

Company name
Editor
Phone number
E-mail

Customer

Supplier

Subject to change

Projec

Issue date
2023-07-29

Last update
2023-07-29