

# DOSING PUMP USER MANUAL

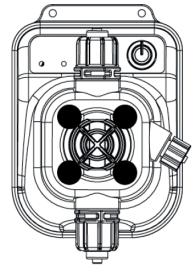
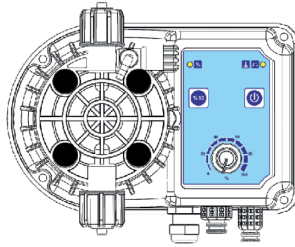
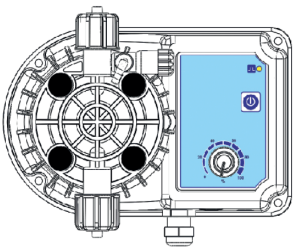

# Contents

---

<b>1</b>	<b>Contents</b>	
1	Contents	1
1.1	List of Pictures	2
2	Introduction	3
2.1	Explanation of Safety Warnings	3
2.2	User Competence	4
3	Safety and Responsibility	5
3.1	General Safety Warnings	5
3.2	Hazards arising from non-compliance with safety instructions	6
3.3	Safe operation	6
3.4	Personal protective equipment	6
3.5	Personnel competence	6
4	Appropriate and Desired Use	7
4.1	Notes about product warranty	7
4.2	Purpose of production	7
4.3	Principles	7
4.4	Prohibited dosage media	7
4.5	Foreseeable wrong use	7
4.5.1	Wrong assembly	7
4.5.2	Wrong installation	7
4.6	Wrong electrical wiring	7
5	Product Description	8
5.1	Product Data	8
5.2	General Specifications	8
5.3	Electrical Features	8
5.4	Scope of delivery	8
6	Technical Data	9
6.1	Operating Conditions and Limits	9
6.2	Electrical Data	9
6.3	Other Information	9
6.3.1	Raw Materials Based on Parts Used in Dosage Pump	9
7	Dimensions	10
7.1	Lara Series Pump Sizes	10
7.1.1	Lara Series Pump Assembly Hole Sizes	10
7.2	Nano Series Pump Sizes	11
7.2.1	Nano Series Pump Hanger Size	11
7.3	Nano Series Pump Assembly Hole Sizes	11
8	Mechanical Installation	12
8.1	Pump Assembly Position	12
9	Electrical Installation	13
9.1	Electrical Connection for DC Models	13
9.2	Electrical Connection for AC Models	13
10	Hydraulic Installation	14
10.1	Manual Venting Hydrolic Installation	14
10.2	Attaching Hose to Pump Head	14
10.1	Automatic Venting Hydrolic Installation	15
10.2	Attaching Hose to Pump Head	15
10.3	Priming	16
10.4	Check Valve and Ball Stroke Line	16
10.5	Suction line	17
10.6	Head Set 40 - 50	17
10.1	Automatic Venting Head Set	18
10.2	Head Set 3	18
11	Operation	19
11.1	Analogue Model Pump Details	19
11.2	LARA APS Function Settings	20
12	Service	21
12.1	Maintenance	21
13	Malfunction Cases	22
13.1	Mechanical Malfunctions	22
13.2	Electrical Malfunctions	22
13.3	Replacing the Fuse	22
14	Chemical Resistance List	23
15	Model List / Flow Pressure Graphic	24
15.1	Model List	24
15.2	Flow Pressure Graphic	25
16	Warranty / Standards	26
16.1	Warranty	26
16.2	Standards	26

**1.1 List of Pictures**

Picture 1 Lara Series Pump Size Front Part	10
Picture 2 Lara Series Pump Size Side Part	10
Picture 3 Lara Series Pump Size Rear Part	10
Picture 4 Lara Series Pump Assembly Hole Sizes	10
Picture 5 Nano Series Pump Size Front Part	11
Picture 6 Nano Series Pump Hanger Size	11
Picture 7 Nano Series Pump Size Side Part	11
Picture 8 Nano Series Pump Size Rear Part	11
Picture 9 Nano Series Pump Assembly Hole Sizes	11
Picture 10 Pump Wall Mount	12
Picture 11 Pump Wrong Assembly Position	12
Picture 12 Pump Correct Assembly Position	12
Picture 13 Electrical Connection for DC Models	13
Picture 14 Electrical Connection for AC Models	13
Picture 15 General Assembly of the Pump	14
Picture 16 Attaching Hose to Pump Head	14
Picture 17 General Assembly for Digital Models	15
Picture 18 Attaching Hose to Pump Head	15
Picture 19 Priming	16
Picture 20 Assembly Order of Check Valve and Ball Stroke Line	16
Picture 21 Suction Line Assembly Diagram	17
Picture 22 Head Set 40-50 Assembly Order	17
Picture 23 Head Set 40-50 Assembly Order	18
Picture 24 Head Set 3 Assembly Order	18
Picture 25 Analogue Pump Usage Functions	19
Picture 26 Maintenance Settings	21
Picture 27 Replacing the fuse	22

## Introduction

### 2 Introduction

Please read following information carefully and completely. This information shall ensure that you benefit from operating instructions at optimum level.

These instructions define the functions of technical data.

#### 2.1 Explanation of Safety Warnings

These operating instructions give information about the technical data and functions of the product. And provide detailed safety information.

Safety warnings and notes are categorized as below. Pictographs are used here as adapted for different circumstances. These pictographs are only for example.



#### **DANGER!**

**Type and source of danger**

**Result: Death or severe injury.**

Measures to be taken to prevent such danger.

Defines the danger that creates the threat directly. Causes death or severe injury unless prevented.



#### **WARNING!**

**Type and source of danger**

**Possible Result: Death or severe injury.**

Measures to be taken to prevent such danger.

Defines a possible dangerous situation. Causes death or grave injury unless prevented.



#### **CAUTION!**

**Type and source of danger**

**Possible Result: Light or insignificant injuries.**

**Material damage.**

Measures to be taken to prevent such danger.

Defines a possible dangerous situation. Causes light or insignificant injury unless prevented. Can also be used for material damage warning.



#### **NOTE!**

**Type and source of danger**

**Result: Causing damage to the product or individuals.**

Measures to be taken to prevent such danger.

Defines a possible damaging action. Causes damage to the product or individuals unless prevented.



#### **INFORMATION!**

**Operational tips and additional information**

**Source of information. Additional measures.**

Defines operational tips and other useful information. Not given for a dangerous or harmful situation.

## 2.2 User Competence



### WARNING!

Danger of injury in case of personnel incompetence!

Operator of device/facility is responsible for complying with competencies.

Incompetent personnel working with the device or keeping the device in danger zone might cause severe injuries or material losses.

- All operations should be handled by competent personnel
- Keep away incompetent personnel from danger zones

Training	Description
Informed Person	Defines a person that has been informed about possible hazards in case of unruly behaviors contrary to duties assigned, and informed about relevant situations and informed about necessary protection equipment and measures.
Trained User	Defines a person that meets the standards of an informed person and plus trained by the manufacturer or another authorized sales partner
Trained Expert	Defines a person that can recognize possible hazards and evaluate the duties assigned thanks to his/her knowledge of rules in addition to the training, information and experience in that field. The activities based on years of experience in that field can be taken into consideration while assessing someone as an expert.
Electricity Expert	Defines a person that can work in electrical facilities, and recognize and prevent possible dangers thanks to his/her knowledge of regulations and standards in place in addition to the training, information and experience. Electricity experts should have received training on the field of work and have knowledge on important standards and regulations. Electricity expert should fulfill the provisions of legal regulations for preventing accidents.
Customer Services	The service technicians that are trained and authorized for operations in the facility by the manufacturer are described as customer services.

## Safety and Responsibility

### 3 Safety and Responsibility

#### 3.1 General Safety Warnings

Following warnings are given for assisting you to eliminate possible dangers that might arise while using the product. Risk prevention measures are always valid independent of any special action. Safety instructions that give warning against certain activities or situations are given in relevant subsections.



#### DANGER

**Life-threatening danger due to electric shock**  
Falsely wired, exposed or damaged cables might injure you.

Replace damaged cables immediately.

Do not use extension cables.

Do not bury cables.

Fix cables to prevent damage to other equipment.



#### DANGER

Do not use the product in explosive environments.



#### WARNING

**Caustic burns due to dosage material or other types of burns!**

Dosage starts after connection to the mains power.

Connect dosage lines before connecting to mains power.

Make sure that all screws are tightened and sealed properly.



#### WARNING

While working on dosage head, valves and connections, you might get in touch with dosage liquid.

Use sufficient personal protective equipment.

Rinse the product with a liquid that doesn't bear any risk (e.g. water). Make sure that the liquid is in line with the dosage material.

Do not look at the exposed ends of attached pipe lines and valves without protective goggles.



#### WARNING

Product materials and system hydraulic parts should be compliant to dosage liquid. Make sure that the materials are suitable for the dosage material.



#### CAUTION

**Increased accident risk due to lack of qualification on personnel side!**

Product and accessories can only be mounted, operated and maintained by staff with sufficient qualifications.

Make sure that all actions are taken by personnel with sufficient and appropriate qualifications.

Prevent access to system by unauthorized persons.



#### CAUTION

**Personal injury and material damage hazard!**

Changing the dosage liquid might cause unforeseeable reactions.

In order to prevent chemical reactions, clean dosage pumps and hoses thoroughly.

### 3.2 Hazards arising from non-compliance with safety instructions

Non-compliance with safety instructions will bring risks not only for the staff but also for environment and the unit.

Here are some specific consequences:

Failure of vital functions in product and system,  
Failure of necessary maintenance and repair methods,  
Danger for individuals due to dangerous dosage material,  
Environmental hazard due to leaking materials.

### 3.3 Safe operation

There are more safety rules in addition to the safety instructions stated in this operating manual and they should be followed:

Accident prevention regulations safety and operating provisions  
Safety measures for using dangerous items  
Environmental protection provisions,  
Applicable standards and legislation.

### 3.4 Personal protective equipment

You might be exposed to dosage liquid. You should use relevant protective equipment depending on the type of work and degree of risk.

As minimum, following protective equipment is provided:



Protective  
Clothing



Protective  
Gloves



Protective  
Goggles

The operator should use protective equipment during these tasks:

Assigning,  
When device is working,  
Demounting, maintenance works, disposal.

### 3.5 Personnel competence

Any staff member working on the device should have specific knowledge and skills.

Anyone working on the device should meet following conditions:

- Participation in all training courses,
- Personal fitness to the specific task,
- Personal competence for the specific task,
- Training for the use of device,
- Safety equipment data and mode of operation
- This Operating Manual and especially the safety instructions relevant to this work with sub-sections,
- Knowledge on basic arrangements relevant to health, safety and accident-prevention.

All persons should have following qualifications as minimum:

- Receive training as expert to work on the product independently,
- Receive sufficient training to work on the product under the guidance and surveillance of a trained expert.

This Operating Manual differentiates user groups: (see User Competence Page 4)

---

## Appropriate and Desired Use

---

### 4 Appropriate and Desired Use

---

#### 4.1 Notes about product warranty

Undefined use of the product in any way might risk the function or desired protection of the product. This shall invalidate warranty claims!

Please remember that responsibility lies with the user in following cases:

- Use of the product in an inconsistent way with the section titled "appropriate and desired use" especially with regards to safety
- Unauthorized changes on the device by the user
  - User's choice of a dosage material different than the one stated in the order.
  - Failure of user to use dosage liquid under predetermined conditions with the manufacturer such as changed concentration, density, temperature, pollution, etc.

#### 4.2 Purpose of production

Dosage pumps are precision dosage devices designed for dosage release of acid, chlorine, liquid fertilizer, etc chemicals (pool, potable water, agricultural irrigation, etc.)

#### 4.3 Principles

- The manufacturer has checked and operated the device under specific conditions before delivery (in a specific density and temperature with a specific dosage material, under specific pipe dimensions, etc.).
- Since such conditions may vary on site under different usages, the capacity of the product should be measured during installation by the operator company.
- Information on usage and environment ([see Technical Data page 9](#)).
- Product materials and system hydraulic parts should be compliant to dosage material. Please remember that resistance of components shall vary depending on dosage material temperature and operating pressure.

- Product is not designed for outdoors unless appropriate protective measures are taken.
- Avoid liquid and dust leakage into product and also direct sunlight exposure.
- Do not operate the product in a potentially explosive environment unless there is EC Certificate of Conformity for potentially explosive atmospheres.

#### 4.4 Prohibited dosage media

Product **should not** be used for following materials and ingredients:

- Gaseous substances,
- Flammable materials,
- Radioactive substances,
- Solid materials.

#### 4.5 Foreseeable wrong use

You can find below information about unaccepted product practices or relevant equipment practices. This section has been designed to detect and prevent possible wrong uses beforehand.

Foreseeable wrong use will affect product life:

##### 4.5.1 Wrong assembly

Wrong or loose screwing.

##### 4.5.2 Wrong installation

Wrong installation of suction and stroke lines.

Wrong connection of pipes due to wrong material or improper connections.

Damage in pipe lines due to twisting or excessive tightening.

Use of damaged parts or exceeding the permitted pressure on suction and discharge sides.

#### 4.6 Wrong electrical wiring

Unsafe mains or mains voltage that do not comply with standards.

Wrong connection cables for mains voltage.

Installation where it is not possible to cut off power supply immediately or easily.



---

## 5 Product Description

---

### 5.1 Product Data

Dosage pumps are precision dosage devices designed for dosage release of acid, chlorine, liquid fertilizer, etc chemicals (pool, potable water, agricultural irrigation, etc.)

### 5.2 General Specifications

This operating manual is applicable to analogue dosage pumps. Installation, operation and service of all these pumping devices are different from each other (certain differences in technical data, malfunctions and repair).

### 5.3 Electrical Features

Device fulfills control duty by respecting user settings.

Device complies with electrical devices regulations.

Device complies with following standards:



TS EN 61000-6-1  
TS EN 61000-6-3  
IEC 60335-2-41  
IEC 60335-1  
EN 60332-41  
EN 60335-1

### 5.4 Scope of delivery

Dosage pump  
User's Manual  
Hose Set  
Suction Line Set 4x6  
Stroke set 4x6-1/2  
Assembly Set  
Hose PE 4x6 2 mt  
Hose PVC 4x6 2 mt 2 pieces

## Technical Data

### 6 Technical Data

#### 6.1 Operating Conditions and Limits

Ambient Temperature	0-45°C
Chemical temperature	0-45°C
Suction Line Max. Height	1,5 mt
Stroke Line Max. Distance	4 mt

#### 6.2 Electrical Data

LARA SERIES	AC	DC
Supply Voltage	AC 230V 50-60Hz	DC 12-28V
Power	17 W	25 W
Current RMS	0,5 A	2,1A
Fuse Current	2A	10A

NANO SERIES	AC
Supply Voltage	AC 230V 50-60Hz
Power	10 W
Current RMS	0,3 A,
Fuse Current	1A

### 6.3 Other Information

Lara Series Product Weight	2,2 kg
Lara Series Box Weight	3,1 kg
Nano Series Product Weight	1,7 kg
Nano Series Box Weight	2,2 kg
Protection Class	IP65

#### 6.3.1 Raw Materials Based on Parts Used in Dosage Pump

Parts Used	LARA Series	Nano Series
Pump Body	PP	
Check valves**	Suction Set	PP, Zirconium Ceramic Ball, Viton-EPDM* Oring
	Stroke Set	PP, Zirconium Ceramic Ball, Viton-EPDM* Oring
	Head Set	PVDF, Zirconium Ceramic Ball, Viton-EPDM* Oring
Diaphragm	PTFE	
Pump Head	PVDF	
O-rings	VITON, EPDM	
Suction Pipe	PVC	
Stroke pipe	PE	
Priming Pipe	PVC	

\*\*,\* may vary in different models.

**7 Dimensions**

Assembly holes are shown in following images.

Mark the surface on which the pump is to be installed in accordance with the template before starting assembly.

Make sure that the surface for pump installation is dry and clean.

**7.1 Lara Series Pump Sizes**

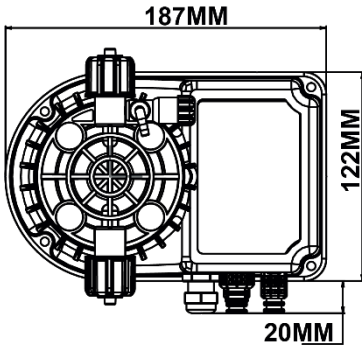

Picture 1 Lara Series Pump Size Front Part

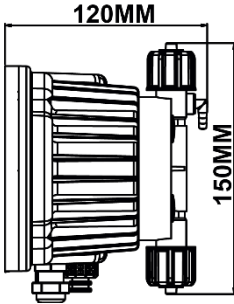

Picture 2 Lara Series Pump Size Side Part

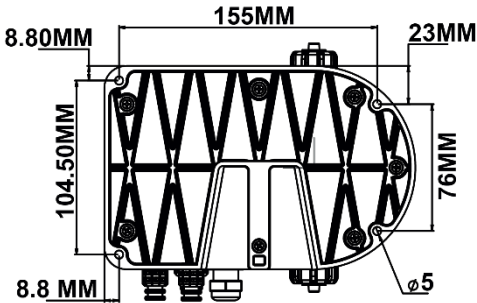

Picture 3 Lara Series Pump Size Rear Part

**7.1.1 Lara Series Pump Assembly Hole Sizes**

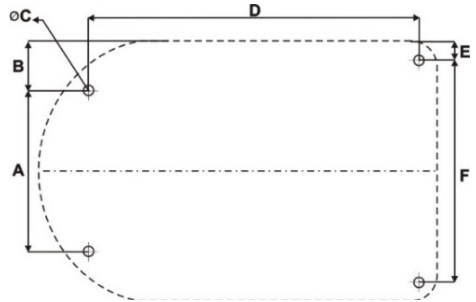

Picture 4 Lara Series Pump Assembly Hole Sizes

**Dimensions**

A	76mm
B	23mm
C	∅ 5mm
D	155mm
E	9mm
F	104mm

## Dimensions

### 7.2 Nano Series Pump Sizes

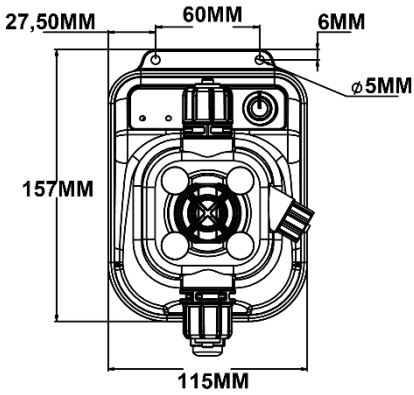

Picture 5 Nano Series Pump Size Front Part

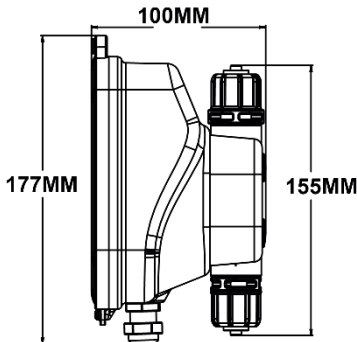

Picture 7 Nano Series Pump Size Side Part

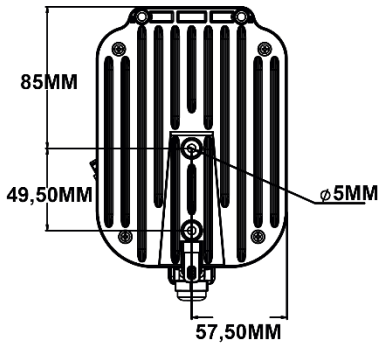

Picture 8 Nano Series Pump Size Rear Part

### 7.2.1 Nano Series Pump Hanger Size

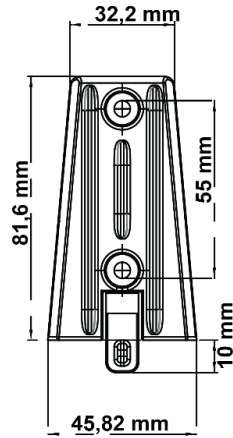

Picture 6 Nano Series Pump Hanger Size

### 7.3 Nano Series Pump Assembly Hole Sizes

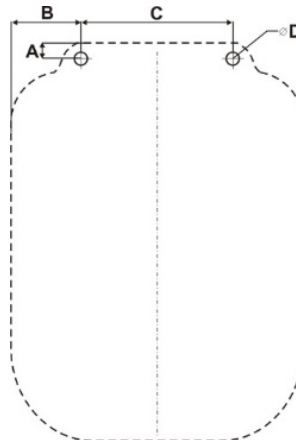

Picture 9 Nano Series Pump Assembly Hole Sizes

#### Dimensions

A	6mm
B	21,5mm
C	60mm
D	Ø 5mm

## 8 Mechanical Installation

Use the hole template in accordance with your pump's model to fix it to a wall  
 Mark the surface that you would like to fix the pump based on given sizes.  
 Drill maximum 7mm hole on the surface to drive in 8mm anchors that you will find among the accessories.  
 After driving in the anchors, place the pump in such a way that holes overlap.  
 Fix with screws.

### Recommended Screw sizes

NANO Series	2 Screws 4,2x50 (Cross Rec. Pan Head)
LARA Series	4 Screws 4,2x50 (Cross Rec. Pan Head)

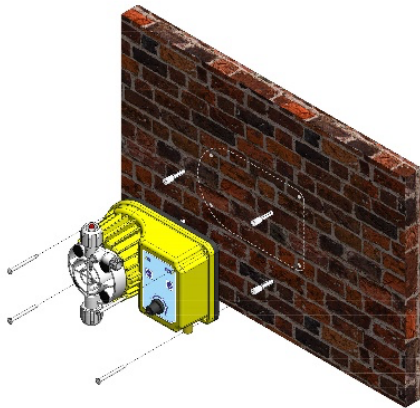

Picture 10 Pump Wall Mount

### 8.1 Pump Assembly Position

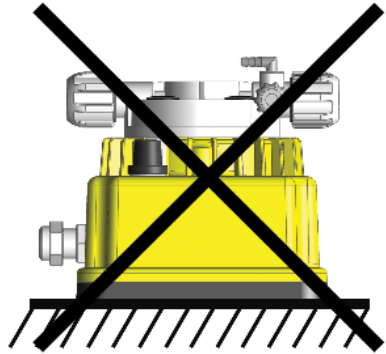

Picture11 Pump Wrong Assembly Position

WRONG ❌

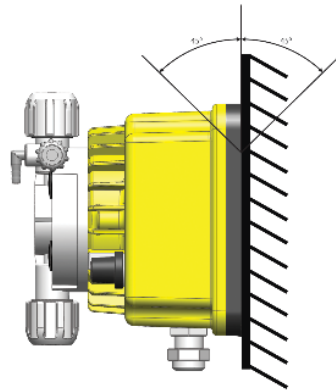

Picture12 Pump Correct Assembly Position

CORRECT ✓



### WARNING

Place the dosage pump vertically  $\pm 45^\circ$ . Fix the pump to a wall or any other vertical surface through two holes on the hanger.

## Electrical Installation

### 9 Electrical Installation

#### 9.1 Electrical Connection for DC Models

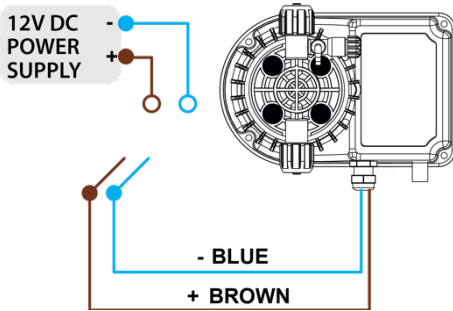

Picture 13 Electrical Connection for DC Models

Electrical connection of 12-28V dosage pump is as seen here.

Brown cable should be connected to + end of power supply whereas blue cable should be connected to - end.

If the cable length on the pump is short, the additional cable should be selected minimum  $1,5\text{mm}^2$ .

#### 9.2 Electrical Connection for AC Models

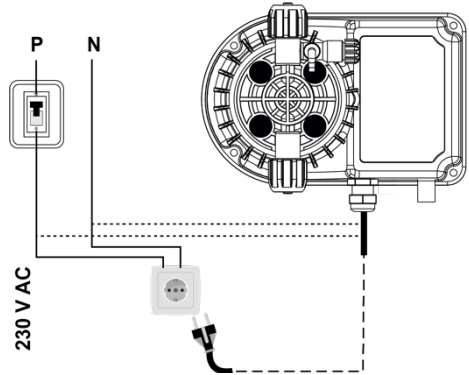

Picture 14 Electrical Connection for AC Models

Electrical connection of LARA and NANO model dosage pumps should be made as seen here.

There is no need for earthing line connection in LARA and NANO model dosage pumps.

If the pump is to be powered using the socket electrical cable on it, then you should choose a wall plug protected with security box.

If the cable length on the pump is short, the additional cable should be selected minimum  $0,75\text{mm}^2$ .

### 10 Hydraulic Installation

#### 10.1 Manual Venting Hydrolic Installation

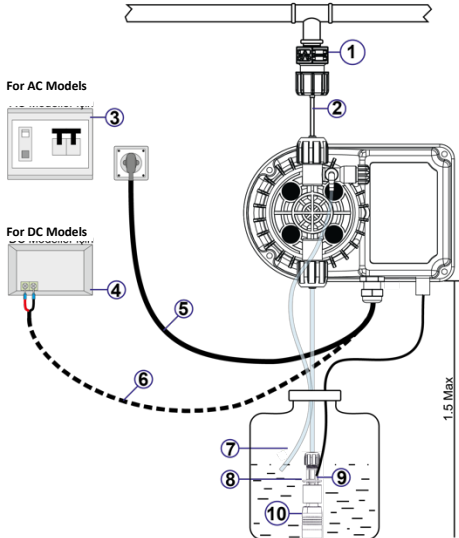

Picture 15 General Assembly of the Pump

- 1) Pumping Line
  - 2) Stroke Line Hose
  - 3) Safety Fuse
  - 4) DC Power Supply
  - 5) AC Power Supply Cable
  - 6) DC Power Supply Cable
  - 7) Priming Hose
  - 8) Suction Line Hose
  - 9) Liquid Level Sensor Cable
  - 10) Suction line
- General assembly of the device should be performed as shown above.
  - Distance between suction line and pump, placed inside the liquid tank, should be maximum 1,5 meters.
  - Assembly should be completed before electrical connection has been made.
  - Electrical connection should be in such a distance not to be affected by liquid or chemicals.

- Device should be placed in a distance that provides ease of use and reading for user's access.
- To make your device long lasting and properly operating, assembly site should not be wet or humid.
- The connection marked with straight line no. 5 is the electrical connection of dosage pump that operates on 230 V AC voltage while no. 6 is for 12-28V DC powered dosage pump.

#### 10.2 Attaching Hose to Pump Head

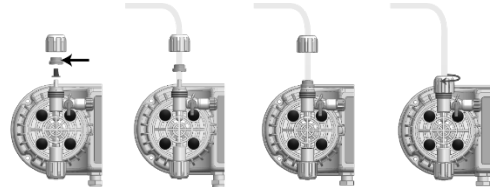

Picture 16 Attaching Hose to Pump Head



Output union (marked with arrow on pump head) should always be on the side of chemical dosing part of the pump head.

Suction union, on the other hand, should be on lower side of the pump.

Remove Union covers.

Remove safety plugs that have been added at production stage.

After passing pipes through union covers, place them on conical tips on unions and tighten the union covers and lock.



**CAUTION**

Remove red protection plugs before hose connection.

## Hydraulic Installation

### 10.1 Automatic Venting Hydrolic Installation

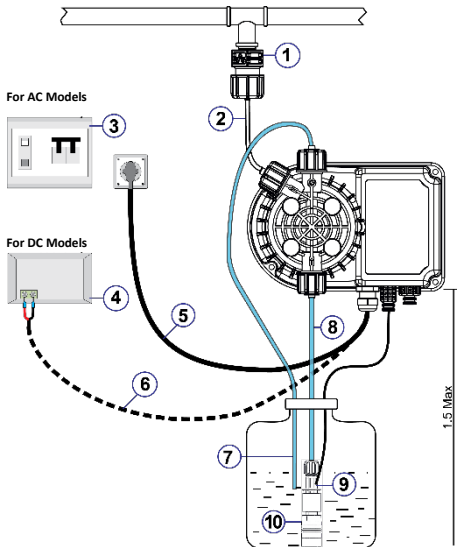

Picture 17 General Assembly for Digital Models

- 1 ) Pumping Line
- 2 ) Stroke Line Hose
- 3 ) Safety Fuse
- 4 ) DC Power Supply
- 5 ) AC Power Supply Cable
- 6 ) DC Power Supply Cable
- 7 ) Priming Hose
- 8 ) Suction Line Hose
- 9 ) Liquid Leve Sensor Cable
- 10) Suction line

General assembly of the device should be performed as shown above.

Distance between suction line and pump, placed inside the liquid tank, should be maximum 1,5 meters.

Assembly should be completed before electrical connection has been made.

Electrical connection should be in such a distance not to be affected by liquid or chemicals.

Device should be placed in a distance that provides ease of use and reading for user's access.

To make your device long lasting and properly operating, assembly site should not be wet or humid.

The connection marked with straight line no. 5 is the electrical connection of dosage pump that operates on 230 V AC voltage while no. 6 is for 12-28V DC powered dosage pump.

### 10.2 Attaching Hose to Pump Head

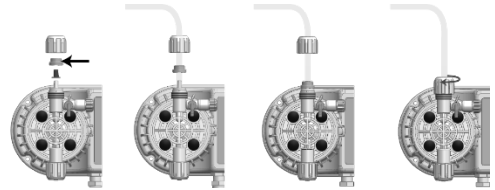

Picture 18 Attaching Hose to Pump Head

Output union (marked with arrow on pump head) should always be on the side of chemical dosing part of the pump head.

Suction union, on the other hand, should be on lower side of the pump.

Remove Union covers.

Remove safety plugs that have been added at production stage.

After passing pipes through union covers, place them on conical tips on unions and tighten the union covers and lock.



#### CAUTION

Remove red protection plugs before hose connection.



### 10.3 Priming

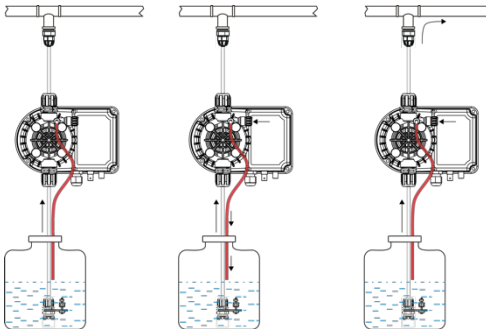

Picture 19 Priming

Before commissioning the pump, air in the pump head should be bled.

For this, attach the PVC hose that you can find among the accessories to the air bleed union on dosage pump, whose assembly and wiring should be completed beforehand, and then send the output to chemical tank

Loosen the air bleed union.

Start the pump.

Check whether chemical is resupplied to the tank from the hose connected to air bleed union.

Priming is over.

Close tight the priming union.

This can not be manually done in models equipped with automatic priming feature.

### 10.4 Check Valve and Ball Stroke Line



#### WARNING

Stroke line should always be placed on upper part of pump marked with arrow (↑). All parts of the stroke line should be attached in the order and direction as shown below. Your pump will not pump if order or direction of parts is changed.

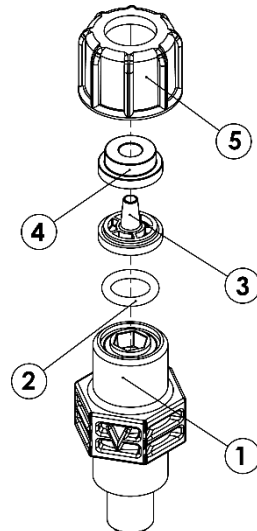

Picture 20 Assembly Order of Check Valve and Ball Stroke Line

No	Description	Unit
1	STROKE BODY 1 PP	1
2	ORING 11,15x2,62	1
3	HOSE TIP 4X6 PP	1
4	HOSE PRESS 4X6 PP	1
5	UNION COVER 2 PP	1

# Hydraulic Installation

## 10.5 Suction line



### WARNING

Suction line should always be attached to lower part of the pump and dipped into chemical tank  
 All parts of the suction line should be attached in the order and direction as shown below.  
 Your pump will not absorb if order or direction of parts is changed.

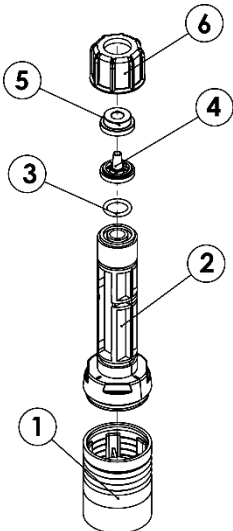

Picture 22 Head Set 40-50 Assembly Order

No	Description	Unit
1	SUCTION FILTER BODY 1 PP	1
2	STROKE BODY 1 PP	1
3	ORING 11x2 VITON	2
4	HOSE TIP 4X6 PP	1
5	HOSE PRESS 4X6 PP	1
6	UNION COVER 2 PP	1

## 10.6 Head Set 40 - 50



### WARNING

All parts of the head set 40 and 50 should be attached in the order and direction as shown below.  
 Your pump will not release chemical if order or direction of parts is changed.

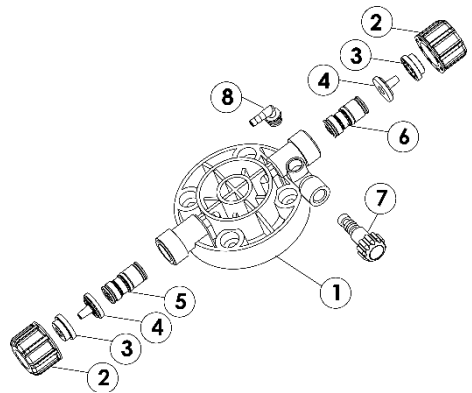

Picture 21 Suction Line Assembly Diagram

No	Description	Unit
1	PUMP HEAD	1
2	UNION COVER	2
3	HOSE PRESS	2
4	HOSE END	2
5	CARTRIDGE SET SUCTION	1
6	CARTRIDGE SET STROKE	1
7	PRIMING UNION	1
8	PRIMING HOSE END	1

### 10.1 Automatic Venting Head Set



#### WARNING

All parts of the head set 40 and 50 should be attached in the order and direction as shown below.

Your pump will not release chemical if order or direction of parts is changed.

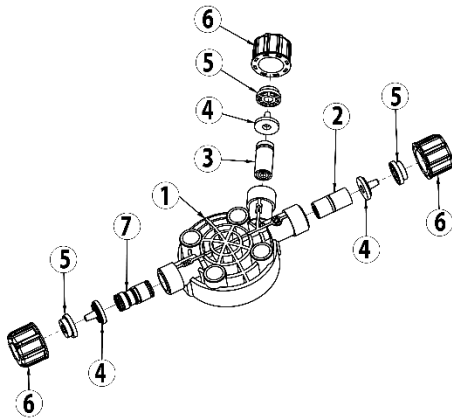

Picture 23 Head Set 40-50 Assembly Order

No	Description	Unit
1	AUTOMATIC VENTING PUMP HEAD	1
2	CHECKVALVE SET FOR AUTOMATIC VENTING	1
3	CHECKVALVE SET FOR DISCHARGE	1
4	HOSE END	3
5	HOSE PRESS	3
6	UNION COVER	3
7	CARTRIDGE SET SUCTION	1

### 10.2 Head Set 3



#### WARNING

All parts of the head set 3 should be attached in the order and direction as shown below.

Your pump will not release chemical if order or direction of parts is changed.

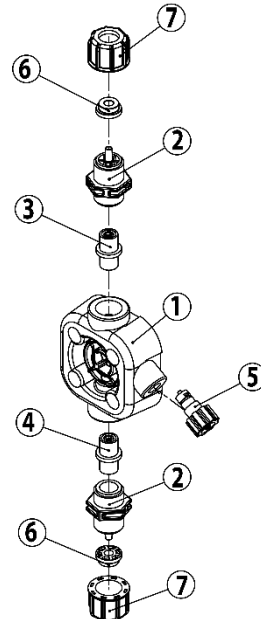

Picture 24 Head Set 3 Assembly Order

No	Description	Unit
1	PUMP HEAD 3 PP GRI	1
2	UNION 4X6 PP	2
3	BALL HOUSING STROKE BODY PP	1
4	BALL SUCTION BODY PP	1
5	UNION PRIMING 1 PP	1
6	HOSE PRESS 4X6 PP	2
7	UNION COVER 2 PP	2

## Operation

### 11 Operation

Your dosage pump operates with a Teflon (PTFE) diaphragm connected to an electromagnet driven with a direct current. When electromagnet pulls the piston, pressure is generated on pump head and released from dosage liquid output valve in a pressurized manner.

Once electricity pulse is interrupted, a spring brings back the piston and liquid enters through input valve.

Easy to use and no need for pump oiling. Consequently, it's maintenance-free.

Materials in pump body are specially manufactured to protect against toxic and acidic substances.

Pumps have been manufactured in various capacities to operate under max 20 Bar pressure between 0 and 20 lt/hour.

Pump capacities are easily adjustable through capacity control pots on them in analogue models.

### 11.1 Analogue Model Pump Details

You can adjust pump capacities of analogue models using the potentiometers on them. You can also mount liquid level sensor to level sensor input to stop operation of the pump when the liquid is consumed up.

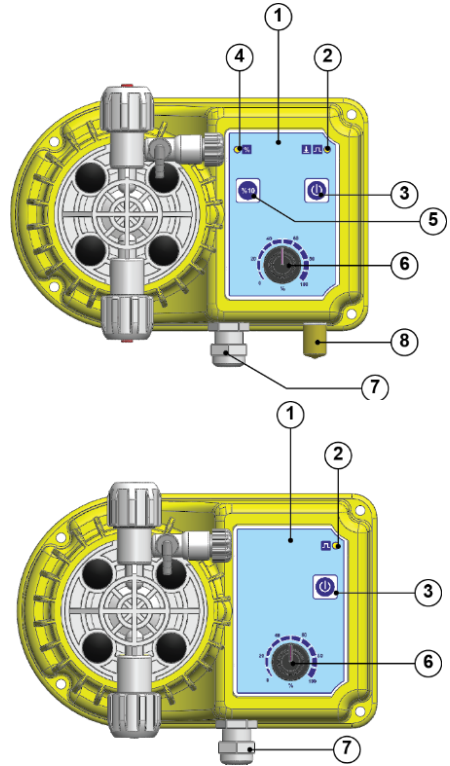

Picture 25 Analogue Pump Usage Functions

No	Description
1	Panel Label
2	Stroke and Level LED
3	On Off Button
4	10% Mode Indication LED
5	10% Mode On Off Button
6	Capacity Control Pot
7	Electrical Connection Union
8	Liquid Level Sensor Input

**11.2 LARA APS Function Settings**

Press 10% button no. 5 in LARA APS models to operate the pump with 10% capacity. LED no. 4 will light when pump is on 10% capacity.

In LARA APS models, Liquid level sensor and Flow Sensor operation mode setting parameter can be selected as normally open or normally closed. To adjust sensor operation type, press and hold 10% button no. 5 until level LED blinks fast. Sensor operation mode will be open when level LED is on, and closed when it is off. Press 10% button no. 5 for switching between open and closed mode. Press Power (Enter) to confirm and save and exit from setting parameter, pump will return to normal operation mode.

## Service

### 12 Service



#### WARNING

Disconnect the power before any service action on the device.

Use 5x20 mm mini cartridge fuse.

If there is a failure in power cable, have it replaced by authorized service.

### 12.1 Maintenance

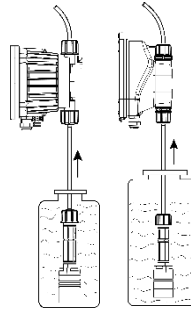

Picture 26 Maintenance Settings

**Before deactivating the device at the end of the season;**

Dismantle stroke line pipe from pumping line.

Remove the suction pipe from liquid tank with the drain and place into clean water.

Operate the pump for 5-10 minutes.

If the cleaning has not been made before deactivating the device at the end of season while using sodium hypochlorite, there might be a solid calcium layer on surfaces of the pump that contacts the chemical.

#### **To clean;**

Dismantle stroke line pipe from pumping line.

Remove the suction pipe from liquid tank with the drain and place into clean water.

Operate the pump for 5-10 minutes.

Turn off the pump and dip the filter into hydrochloric acid and wait until acid cleans it.

Restart the pump and operate it for 5 minutes while keeping the suction filter and pumping union in the same tank.

Repeat the process with water.

Reconnect the pump



#### CAUTION

Check the liquid level in chemical tank periodically so that you are not running the pump without dosage liquid.

Check pump operation with at least 5 hours intervals.

Hydraulic parts should be cleaned periodically however it depends on application type how frequently.

**13 Malfuction Cases**

**13.1 Mechanical Malfuctions**

If the system is fully silent, probably there is an electrical or electronic failure rather than a mechanical one.

If there is a loss in dosage liquid in fixed interval, then the union covers might be loose or pumping line pipe might be cracked or there might be cracks in diaphragm (although quite rare) or 4 screws holding the pump head might be loose.

If there is air formation when pump is not in use, then check all check valves in the system and replace if necessary.

**13.2 Electrical Malfuctions**

If LEDs do not light

Check power cable.

Make sure that only authorized staff or service intervenes in all malfuctions in the power cable. Key should be on.

If your pump is operated on AC power supply, electrical values will be as follows;

AC 230V 50-60Hz

Check pump fuse. If it is faulty and if your pump is on AC voltage, replace it with 2A cartridge fuse. If the new fuse is also blowing, contact the pump dealer.



**CAUTION**

Selection of Fuse Based on Supply Voltage  
 12-28V DC      10A 5x20 cartridge fuse  
 Lara 230 V AC   2A 5x20 cartridge fuse  
 Nano 230 V AC   1A 5x20 cartridge fuse



**CAUTION**

If the problem is none of those or if there is a different problem, contact the pump dealer

**13.3 Replacing the Fuse**



**WARNING**

Disconnect the power before any service action on the device.



**WARNING**

Use 2A cartridge fuse in AC Dosage pumps.  
 Use 10A cartridge fuse in DC Dosage pumps.

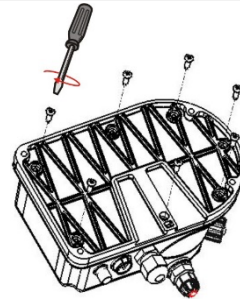

Picture 27 Replacing the fuse

Remove the screws on the back cover with appropriate screwdriver to replace the pump fuse.

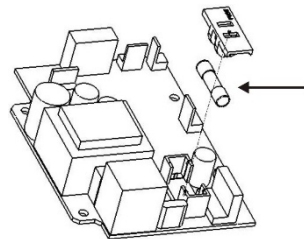

Replace the cartridge fuse on the electronic card with the new one.

Make sure that electronic card is not damaged. Your pump will not operate if the electronic card is damaged.

Failures due to user's fault on the electronic card are not covered by the guarantee.

Then close the pump back cover.

## Chemical Resistance List

### 14 Chemical Resistance List

Chemical	Formula	Glass	PVDF	PP	PVC	SS316	PMMA	Hastelloy	PTFE	FPM	EPDM	NBR	PE	Neoprene	Silicone
Acetic Acid, Max 75%	CH <sub>3</sub> COOH	2	1	1	1	1	3	1	1	3	1	3	1	3	1
Aluminium Sulphate	Al <sub>2</sub> (SO <sub>4</sub> ) <sub>3</sub>	1	1	1	1	1	1	1	1	1	1	1	1	1	1
Amines	R-NH <sub>2</sub>	1	2	1	3	1	---	1	1	3	2	4	1	---	---
Calcium Hydroxide	Ca(OH) <sub>2</sub>	1	1	1	1	1	1	1	1	1	1	1	1	1	1
Calcium Hypochlorite	Ca(OCl) <sub>2</sub>	1	1	1	1	3	1	1	1	1	1	3	1	2	2
Copper Sulphate	CuSO <sub>4</sub>	1	1	1	1	1	1	1	1	1	1	1	1	1	1
Ferric Chloride	FeCl <sub>3</sub>	1	1	1	1	3	1	1	1	1	1	1	1	1	2
Hydrofluoric Acid 40%	HF	3	1	1	2	3	3	2	1	1	3	3	1	3	3
Hydrochloric Acid	HCl	1	1	1	1	3	1	1	1	1	3	3	1	2	2
Hydrogen Peroxide 30%	H <sub>2</sub> O <sub>2</sub>	1	1	1	1	1	3	1	1	1	2	3	1	2	1
Nitric Acid 65%	HNO <sub>3</sub>	1	1	2	3	2	3	1	1	1	3	3	2	3	3
Phosphoric Acid 50%	H <sub>3</sub> PO <sub>4</sub>	1	1	1	1	2	1	1	1	1	1	3	1	2	1
Potassium Permanganate 10%	KMnO <sub>4</sub>	1	1	1	1	1	1	1	1	1	1	3	1	---	---
Sodium Bisulphate	NaHSO <sub>3</sub>	1	1	1	1	2	1	1	1	1	1	1	1	1	1
Sodium Carbonate	Na <sub>2</sub> CO <sub>3</sub>	2	1	1	1	1	1	1	1	2	1	1	1	1	1
Sodium Hydroxide	NaOH	2	1	1	1	1	1	1	1	2	1	2	1	1	2
Sodium Hypochlorite 12,5%	NaOCl + NaCl	1	1	2	1	3	1	1	1	1	1	2	1	1	2
Sulphuric Acid 85%	H <sub>2</sub> SO <sub>4</sub>	1	1	1	1	2	3	1	1	1	3	3	1	3	3
Sulphuric Acid 98,5%	H <sub>2</sub> SO <sub>4</sub>	1	1	3	3	3	3	1	1	1	3	3	3	3	3

1 :Resistant

2 :Good

3 :Non-Resistant



**15 Model List / Flow Pressure Graphic**

**15.1 Model List**

MODEL	Max/L t	Max/ P	Stroke/mi n	ml/Strok e	Supply Voltage	Wat t	Weigh t	Body	Max Ambient Temperatur e	Max Chemical Temperatur e
	Lt/h	Bar	Stroke	ml	Volt	W	kg	IP	°C	°C
LARA A LARA APS	2	10	120	0.278	12-28 VDC	25	2.2	65	0-45	0-40
	2	10	150	0.222	230V AC	17				
	5	7		0.555						
	5	5	120	0.694	12-28 VDC	25				
	10	5	150	1.111	230V AC	17				
	2	20		0.222						
NANO	2	10	180	0.185	230V AC	10	1.7			
	5	5		0.463						
	0.5	5		0.046						

# Model List / Flow Pressure Graphic

## 15.2 Flow Pressure Graphic

### LARA 10L/5B

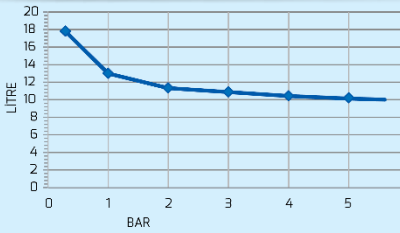

### LARA 5L/7B

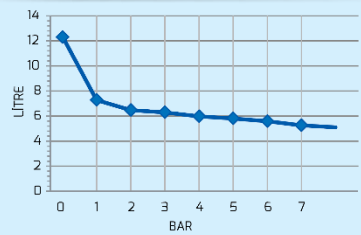

### LARA 2L/20B

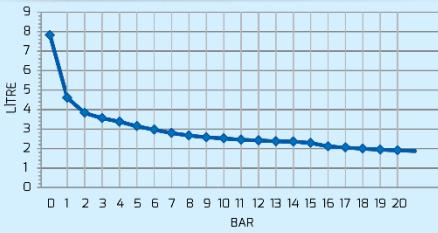

### LARA 2L/10B

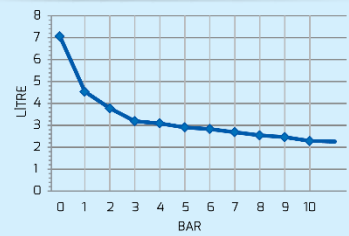

### NANO 5L/5B

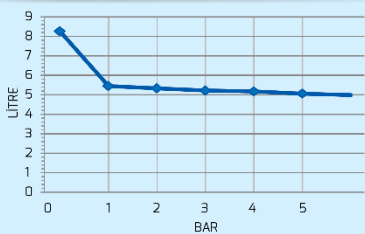

### NANO 2L/10B

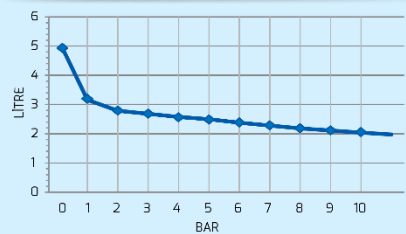

### NANO 0,5L/5B

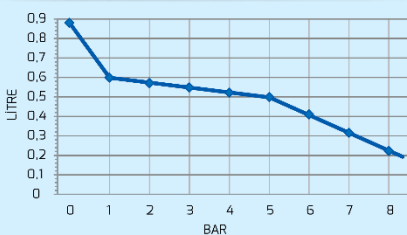

---

## 16 Warranty / Standards

---

### 16.1 Warranty

Dosage Pump is under warranty for 2 years against damages arising from material and manufacturing faults according to legal regulations.

Damages arising from normal wear, overloading or undue usage are not covered by warranty.

Damages from material or manufacturing faults shall be compensated by repairing or replacing faulty part or the device completely.

Claims of warranty shall be accepted only if device is returned to the supplier or authorized service in full shape **without disassembly**.



#### CAUTION

Warranty Certificate should be filled and approved by the dealer where you buy the device. Please have the certificate stamped by the dealer and keep it.

### 16.2 Standards



TS EN 61000-6-1

TS EN 61000-6-3

IEC 60335-2-41

IEC 60335-1

EN 60332-41

EN 60335-1

