



Franklin Electric

SUBMERSIBLE PUMPS FOR SEWAGE

ED-EGT/EGF, FWS-FWC, FGR AND FLV SERIES



INDEX

ED-EGT/EGF SERIES - DRAINAGE PUMPS 50 HZ

ED - Stainless steel drainage submersible pumps for dirty water	6
Features & benefits	6
Pump identification code.....	6
General features	6
Spare parts and materials.....	8
Dimensions and weights.....	8
Installation.....	9
ED Hydraulic performance at 50 Hz \approx 2900 l/min	10
Features & benefits	11
Pump identification code.....	11
General features	12
Design features.....	13
Spare parts and materials.....	14
Dimensions and weights.....	14
Installation.....	15
EGT/EGF hydraulic performance at 50 hz \approx 2900 l/min.....	16

FWS-FWC SERIES - WASTEWATER LIFT PUMPS 50 HZ

Pump identification code.....	18
32FWS V Series 50 HZ	19
Features & benefits	19
General features	20
Dimensional drawings.....	21
Technical data	22
Hydraulic performance at 50 Hz.....	22
Performance curves at 50 Hz.....	23
Installation.....	24
40FWS V Series 50 HZ	25
Features & benefits	25
General features	26
Dimensional drawings.....	27
Technical data	28
Hydraulic performance at 50 Hz.....	28
Performance curves at 50 Hz.....	29
Installation.....	30
50FWS V Series 50 HZ	31
Features & benefits	31
General features	32
Dimensional drawings.....	33
Technical data	34
Hydraulic performance at 50 Hz.....	34
Hydraulic performance at 50 Hz.....	35
Installation.....	36

Franklin Electric S.r.l. reserves the right to amend specification without prior notice.

For the most up-to-date product information, visit franklinwater.eu.

50FWC V Series 50 HZ	37
Features & benefits	37
General features	38
Dimensional drawings	39
Technical data	40
Hydraulic performance at 50 Hz	40
Hydraulic performance at 50 Hz	41
Installation	42
50FWC M Series 50 HZ	43
Features & benefits	43
General features	44
Dimensional drawings	45
Technical data	46
Hydraulic performance at 50 Hz	46
Hydraulic performance at 50 Hz	47
Installation	48
50FWC V4 Series 50 HZ	49
Features & benefits	49
General features	50
Dimensional drawings	51
Technical data	52
Hydraulic performance at 50 Hz	52
Hydraulic performance at 50 Hz	53
Installation	54
65FWC V Series 50 HZ	55
Features & benefits	55
General features	56
Dimensional drawings	57
Technical data	58
Hydraulic performance at 50 Hz	58
Hydraulic performance at 50 Hz	59
65FWC M Series 50 HZ	61
Features & benefits	61
General features	62
Dimensional drawings	63
Technical data	64
Hydraulic performance at 50 Hz	64
Hydraulic performance at 50 Hz	65
Installation	66
65FWC V4 Series 50 HZ	67
Features & benefits	67
General features	68
Dimensional drawings	69
Technical data	70
Hydraulic performance at 50 Hz	70
Hydraulic performance at 50 Hz	71
Installation	72

Franklin Electric S.r.l. reserves the right to amend specification without prior notice.

For the most up-to-date product information, visit franklinwater.eu.



80FWC M4 Series 50 HZ	73
Features & benefits	73
General features	74
Dimensional drawings	75
Technical data	76
Hydraulic performance at 50 Hz	76
Hydraulic performance at 50 Hz	77
80FWC V4 Series 50 HZ	79
Features & benefits	79
General features	80
Dimensional drawings	81
Technical data	82
Hydraulic performance at 50 Hz	82
Hydraulic performance at 50 Hz	83
100FWC M4 Series 50 HZ	85
Features & benefits	85
General features	86
Dimensional drawings	87
Technical data	88
Hydraulic performance at 50 Hz	88
Hydraulic performance at 50 Hz	89
Installation	90
FGR SERIES - PUMPS WITH GRINDER UNIT 50 HZ	
Pump identification code	92
40FGR Series 50 HZ	93
Features & benefits	93
General features	94
Dimensional drawings	95
Technical data	96
Hydraulic performance at 50 Hz	96
Performance curves at 50 Hz	97
Installation	98
50FGR Series 50 HZ	99
Features & benefits	99
General features	100
Dimensional drawings	101
Technical data	102
Hydraulic performance at 50 Hz	102
Performance curves at 50 Hz	103
Installation	104
FLV SERIES - D.C. MOTOR SUBMERSIBLE WASTE WATER LIFT PUMPS 50 HZ	
Pump identification code	106
40FLV Series	107
Features & benefits	107
General features	108
Dimensional drawings	109
Technical data	110
Hydraulic performance at 50 Hz	110
Performance curves at 50 Hz	111
Installation	112

Franklin Electric S.r.l. reserves the right to amend specification without prior notice.

For the most up-to-date product information, visit franklinwater.eu.

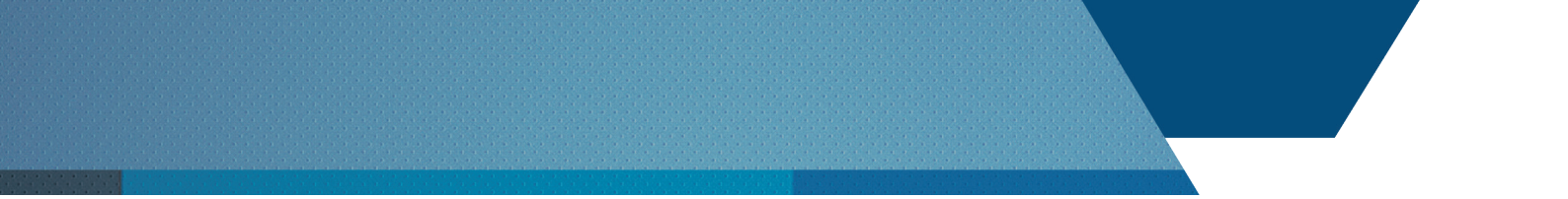

ED-EGT/EGF Series - Drainage pumps 50 Hz



ED – STAINLESS STEEL DRAINAGE SUBMERSIBLE PUMPS FOR DIRTY WATER

FEATURES & BENEFITS

APPLICATIONS



For clean and dirty water, containing solids up to 35 mm grain size



The construction with smooth surfaces in rolled-stainless steel and easy access for cleaning is suitable for certain uses in the food industry

FOR CLEAN AND DIRTY WATER, SOLIDS UP TO 35 MM

- Containing solids up to 35 mm grain size
- Stainless steel pump casing and impeller
- Vertical delivery port
- Double mechanical seal in oil chamber
- Dry winding motor, designed in accordance with: EN 60034-1; EN 60335-1, EN 60335-2-41

PUMP IDENTIFICATION CODE

ED 7 T 400 50

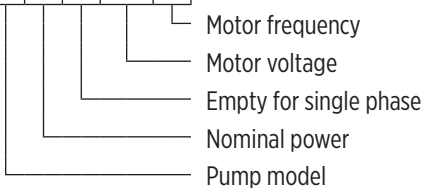

GENERAL FEATURES

Model	ED	
Max. head	13	
Flow [m ³ /h]	up to 26 m ³ /h	
Liquid temperature range [°C]	up to 35 °C	
Minimum immersion depth	248 mm	
Maximum immersion depth:	5 m	
Maximum solids size:	35 mm	
Power cable:	Single-phase	H07RN-F, 3G1 mm ² , length 10 m (5 m for ED5), with plug Cel-UnaL 47166 / Schuko
	Three-phase	H07RN-F, 4G1 mm ² , length 10 m (5 m for ED5), without plug
Motor power [kW]:	0.55 - 0.9 kW	
Motor type:	2-pole induction motor, 50 Hz (n ≈ 2900 rpm)	
Motor standard voltage:	Single-phase	230 V ± 10 %; with float switch and thermal protector
	Three-phase	400 V ± 10 %
Protections:	Insulation class: F Protection: IPX8 (for continuous immersion) Triple impregnation humidity-proof dry winding	
Capacitor:	Built-in for single phase version	
Float switch:	Included in single phase version	

00140020EN 09/2023

HYDROPOMPE

DESIGN FEATURES

Power cable with plug on single-phase pumps

Handle in polypropylene, with frame in stainless steel

Easy inspection of the capacitor area

Easy adjustment of the float switch: to allow the adjustment of start/stop pump levels

Ring against accidental extraction of the cable

G 1 ½ vertical, upward delivery port for installation in small pits, without the need for an elbow on the pump

The double shaft seal with oil chamber separates the motor from the water and provides further protection against accidental operation when dry

Totally in stainless steel all parts in contact with the pumped liquid both internal and external are in stainless steel AISI 304

Shaft in chrome-nickel stainless steel

ED
The two-passage impeller construction is particularly suitable for liquids containing solids up to 35 mm grain size.

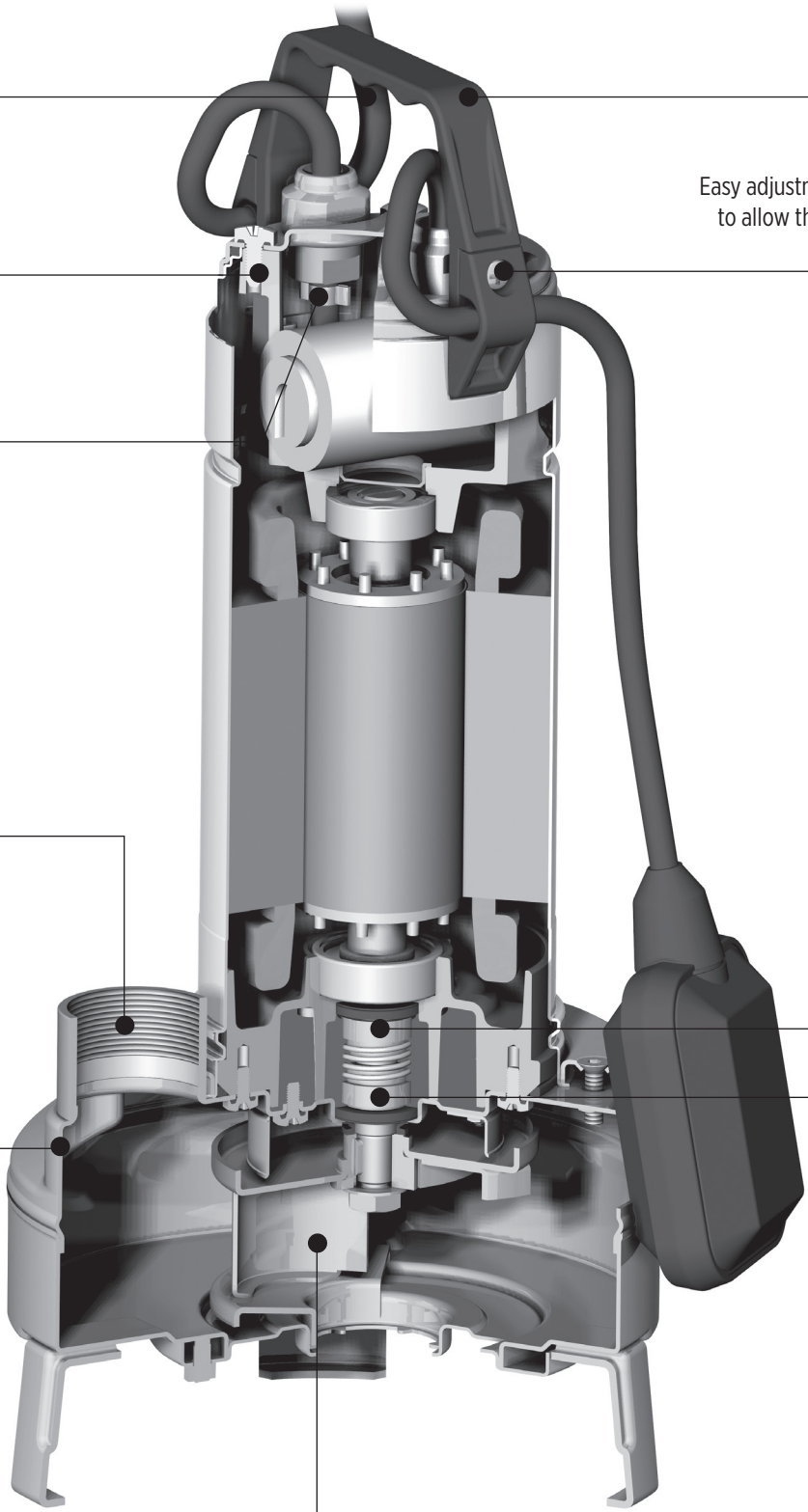

SPARE PARTS AND MATERIALS

Parts description	Material	Standard	
		ASTM/AISI	DIN/EN
Pump casing / Impeller Motor jacket / Jacket cover Casing cover / Shaft	Chrome-nickel steel	AISI 304	1.4301 / EN 10088
Handle	Polypropylene (with frame in AISI 304)	-	-
Upper mechanical seal / Lower mechanical seal	Ceramic alumina / Carbon / NBR	-	-
Seal lubrication oil	Oil for food / Pharmaceutical machinery	-	-

DIMENSIONS AND WEIGHTS

Pump model	Dimensions [mm]			h min	
	fM	h max	h min	Single-phase	Three-phase
ED 5	433	508	248	12	10.3
ED 9	458	533	273	14	12.5

DIMENSIONAL DRAWINGS

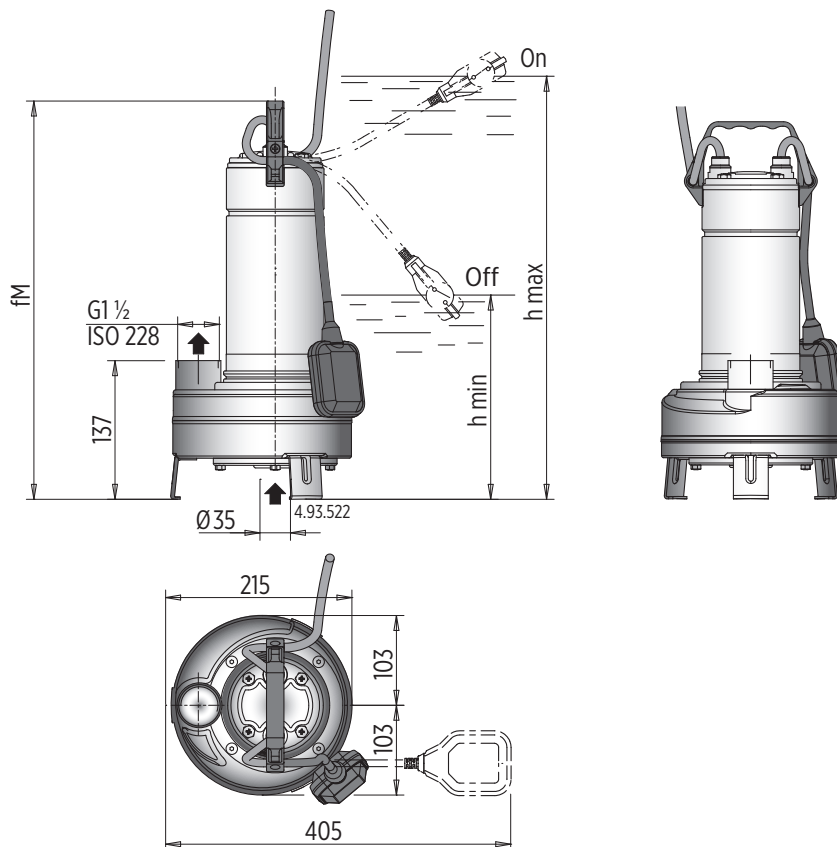

00130114 02/2018

INSTALLATION

STATIONARY INSTALLATION

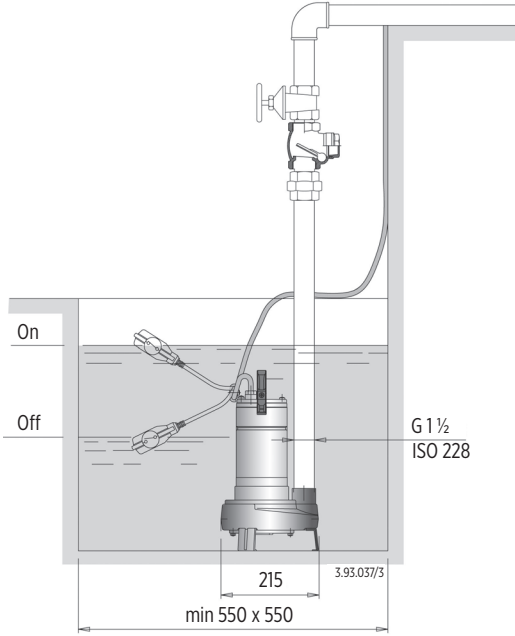

TRANSPORTABLE INSTALLATION

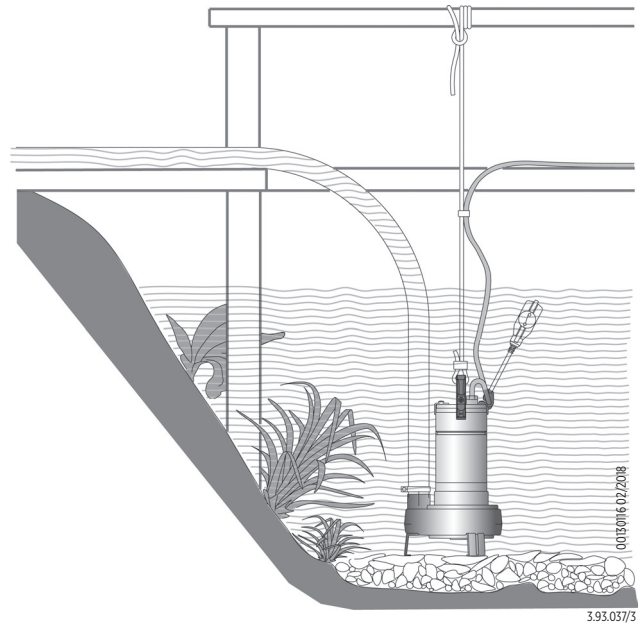

CONNECTION EXAMPLES

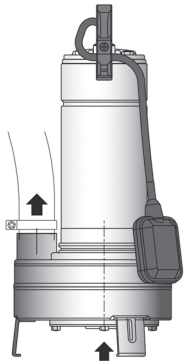

Pump with hoesetail seat and clamp
(locally available)

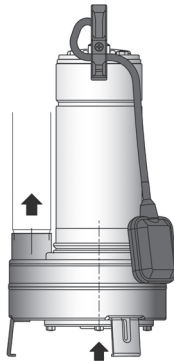

Pump with pipe screwed into the
delivery port

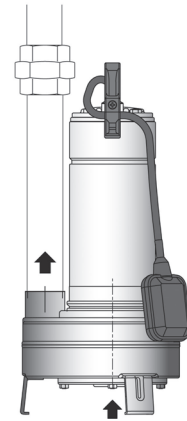

Pump with pipe and union
(locally available)

0033017EN 02/2018

ED HYDRAULIC PERFORMANCE AT 50 HZ ≈ 2900 1/MIN

Pump model	1x230 V			P ₁	P ₂		Q = Delivery											
	Capacitor						l/min	50	100	150	200	250	300	350	400	433		
	[A]	[μf]	[Vc]	[kW]	[kW]	[HP]	m ³ /h	0	3	6	9	12	15	18	21	24	26	
ED 5	4.6	16	450	1	0.55	0.75	10.4	9	8	7.1	6.3	5.4	4.4	3.2	-	-		
ED 9	6.6	25	450	1.45	0.9	1.2	12.9	11.6	10.5	9.5	8.7	7.8	6.9	5.9	4.7	4		

P₁ : Max absorbed power

P₂ : Motor nominal power

Density ρ = 1000 Kg/m³

Viscosity kinematic ν = max 20 mm²/sec

Pump model	3x230 V		P ₁	P ₂		Q = Delivery											
	3x400 V					l/min	50	100	150	200	250	300	350	400	433		
	[A]	[kW]	[kW]	[HP]	m ³ /h	0	3	6	9	12	15	18	21	24	26		
ED 5 T	2.8	1.6	1	0.55	0.75	10.4	9	8	7.1	6.3	5.4	4.4	3.2	-	-		
ED 9 T	4	2.3	1.45	0.9	1.2	12.9	11.6	10.5	9.5	8.7	7.8	6.9	5.9	4.7	4		

P₁ : Max absorbed power

P₂ : Motor nominal power

Density ρ = 1000 Kg/m³

Viscosity kinematic ν = max 20 mm²/sec

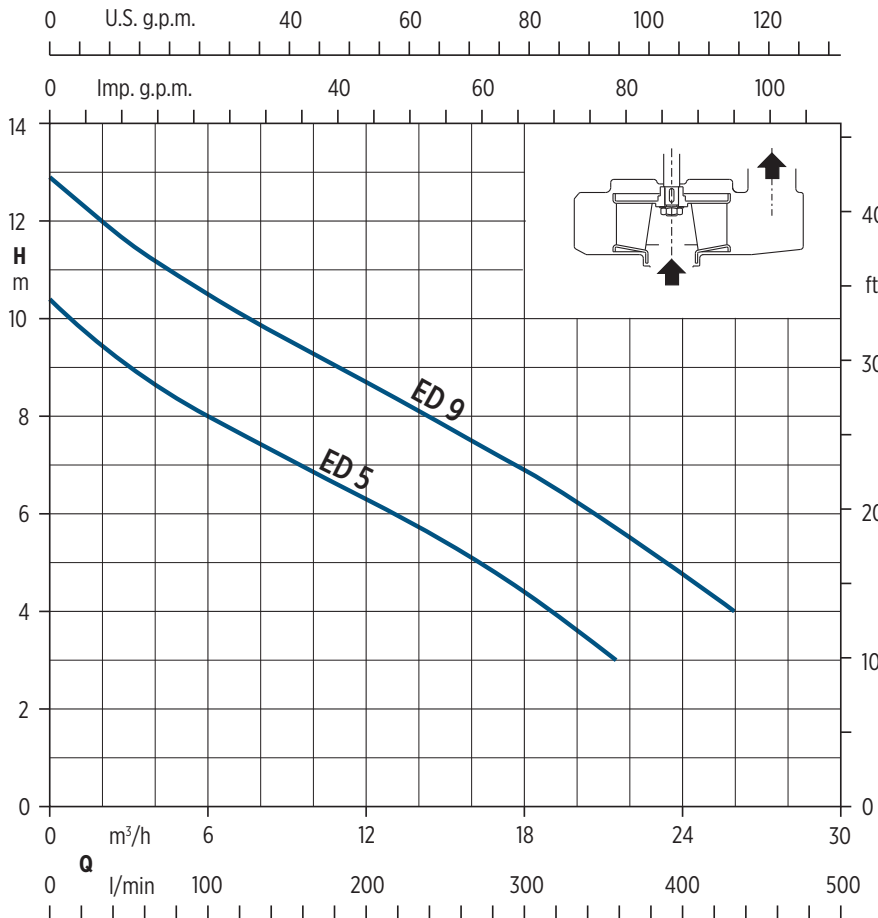

00120124 02/2018

EGT/EGF – SUBMERSIBLE DRAINAGE PUMP FOR DIRTY WATER

FEATURES & BENEFITS

APPLICATIONS



Domestic or industrial waste water, dirty water containing solids up to 50 mm grain size, for liquids which are compatible with the pump materials



Draining rooms, tank drainage



Extraction of water from ponds, streams or pits and for rainwater collection

FOR DIRTY WATER, SOLIDS UP TO 50 mm

- Containing solids up to 50 mm grain size, for liquids which are compatible with the pump materials
- Free-flow (Vortex) impeller construction
- Cast iron pump casing and impeller with epoxy cataphoresis treatment
- Vertical delivery port (G 2")
- Double mechanical seal in oil chamber, to protect against dry-running
- Silicon carbide mechanical seal version on request
- Dry winding motor, designed in accordance with: EN 60034-1; EN 60335-1, EN 60335-2-41

PUMP IDENTIFICATION CODE

7	T	400	50	F	SIC
---	---	-----	----	---	-----

Mechanical seal version: Silicon carbide / Silicon carbide (on request)

F for pump with float switch (Empty without float switch)

Motor frequency

Motor voltage

Empty for single phase

Nominal power

Pump model

EGT: with vertical threaded delivery port G 2"

EGF: with horizontal flanged and threaded delivery port G 2" - DN50

0014002ZEN 02/2018

GENERAL FEATURES

Model		EGT	EGF
Max. head		15	
Flow [m ³ /h]		up to 26 m ³ /h	
Liquid temperature range [°C]		up to 35 °C	
Minimum immersion depth		275 mm	
Maximum immersion depth:		5 m	
Maximum solids size:		50 mm	
Power cable:	Single-phase	H07RN-F, 3G1 mm ² , length 10 m, with plug Cel-UneL 47166	
	Three-phase	H07RN-F, 4G1 mm ² , length 10 m (5 m for ED5), without plug	
Motor power [kW]:		0.55 - 1.5 kW	
Motor type:		2-pole induction motor, 50 Hz (n ≈ 2900 rpm)	
Motor standard voltage:	Single-phase	230 V ± 10 %; with float switch and thermal protector	
	Three-phase	400 V ± 10 %	
Protections:		Insulation class: F Protection: IPX8 (for continuous immersion) Triple impregnation humidity-proof dry winding	
Capacitor:		Built-in for single phase version	
Float switch:		Included in single phase version	

DESIGN FEATURES

Cable length 10 m, pump single-phase with plug

Handle in polypropylene, with frame in stainless steel

Easy inspection of the capacitor area

Easy adjustment of the float switch to allow the adjustment of start/stop pump levels

Ring against accidental extraction of the cable

The double shaft seal with oil chamber separates the motor from the water and provides further protection against accidental operation when dry

Relief valve: the pump is fitted to a relief valve for air release around the impeller granting a proper pump priming also after long standstill periods

Maximum flexibility of connection:

- Flange DN 50 PN 10 EN 1092-2
- N. 4 M8 holes on Ø 90 for duck foot coupling SA-G2"
- G 2" ISO 228

Chamber with food / Pharmaceutical machinery oil

Impeller with epoxy cataphoresis treatment for a greater protection against corrosion

Pump casing with epoxy cataphoresis treatment joined to the external paint for a greater protection against the corrosion

Shaft in chrome-nickel stainless steel

The free-flow impeller (vortex) construction is particularly suitable for liquids containing solids up to 50 mm grain size

EGT

G 2" vertical, upward delivery port for installation in small pits, without the need for an elbow on the pump.

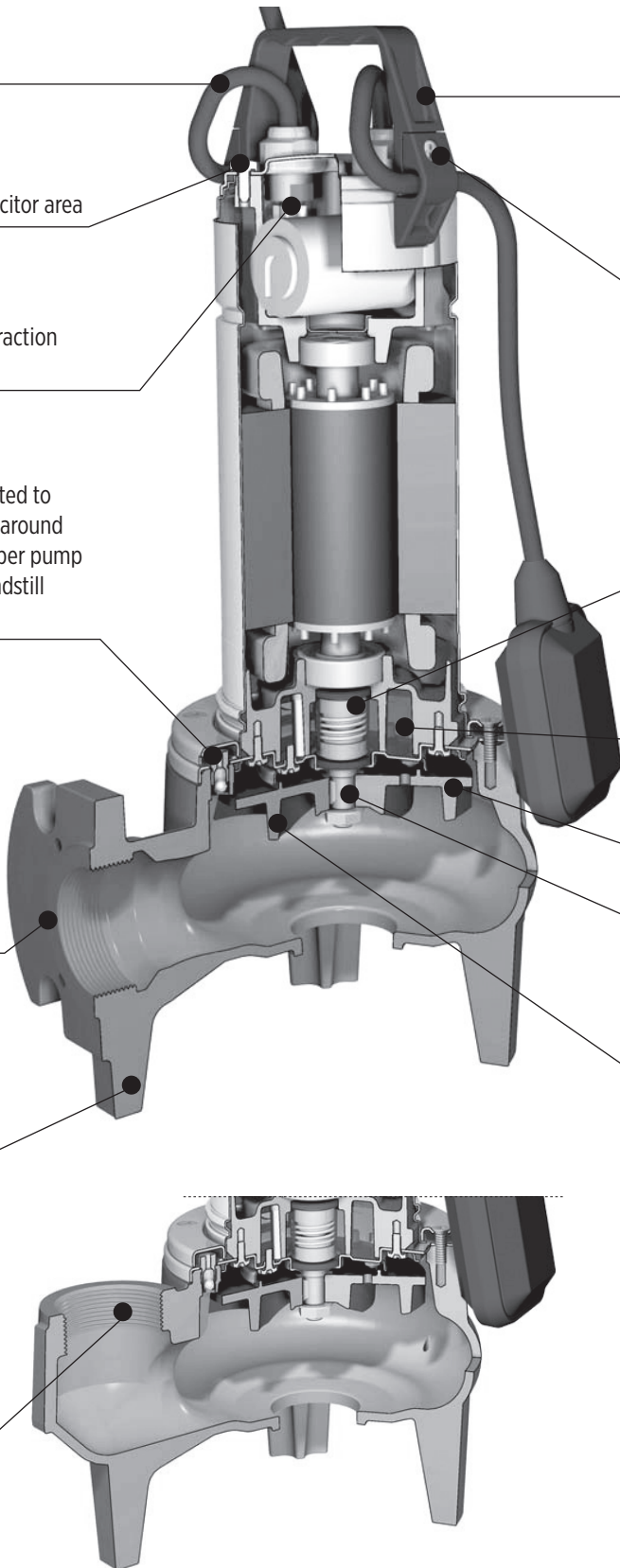

SPARE PARTS AND MATERIALS

Parts description	Material	Standard	
		ASTM/AISI	DIN/EN
Pump casing / Impeller	Cast iron GJL 200	-	EN 1561
Strainer / Motor jacket / Jacket cover Casing cover / Shaft	Chrome-nickel steel	AISI 304	1.4301 / EN 10088
Handle	Polypropylene (with frame in AISI 304)	-	-
Upper mechanical seal / Lower mechanical seal	Ceramic alumina / Carbon / NBR	-	-
Seal lubrication oil	Oil for food / Pharmaceutical machinery	-	-

DIMENSIONS AND WEIGHTS

Pump model	Dimensions [mm]			h min	
	H	h max	h min	Single-phase	Three-phase
EGT 7 (T)	460	535	275	16	15
EGT 9 (T)	485	560	300	17.8	15.8
EGT 11 (T)	505	580	320	20.3	18.8
EGT 15 T	505	580	320	-	20.3
EGT 15	535	610	350	21.8	-

Pump model	Dimensions [mm]			h min	
	H	h max	h min	Single-phase	Three-phase
EGF 7 (T)	460	535	275	16.2	15.2
EGF 9 (T)	485	560	300	18	16
EGF 11 (T)	505	580	320	20.5	19
EGF 15 T	505	580	320	-	20.5
EGF 15	535	610	350	22	-

DIMENSIONAL DRAWINGS

EGT

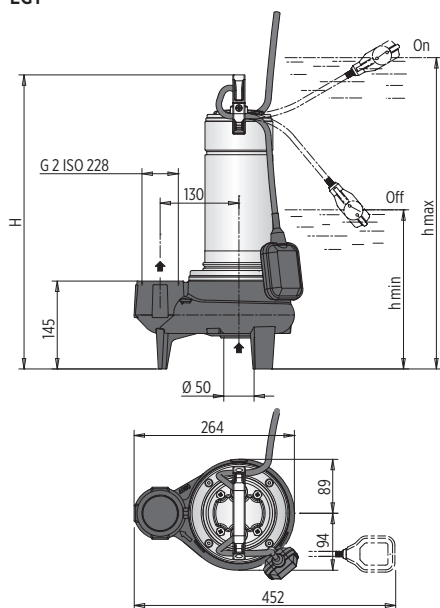

EGF

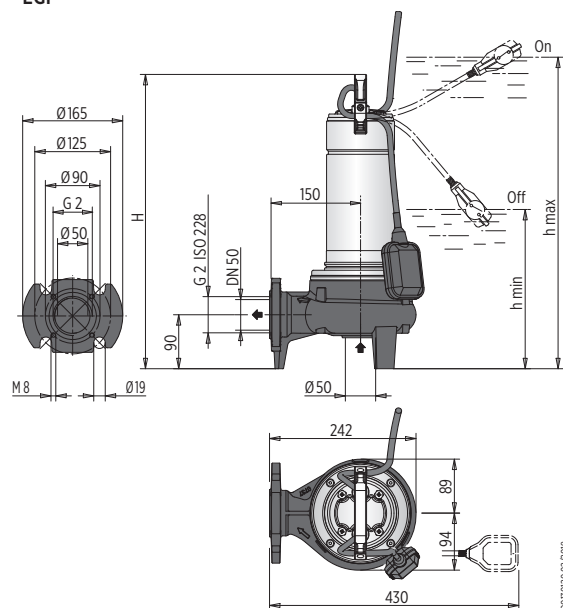

000020/02/2018

INSTALLATION

STATIONARY INSTALLATION

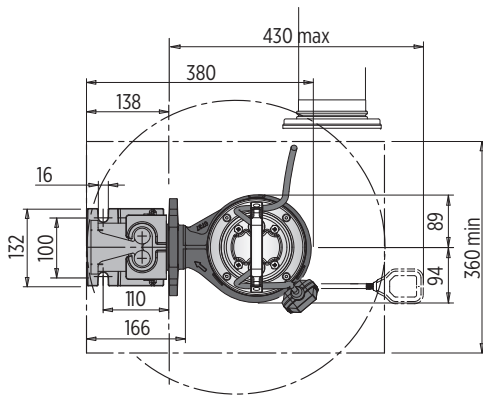
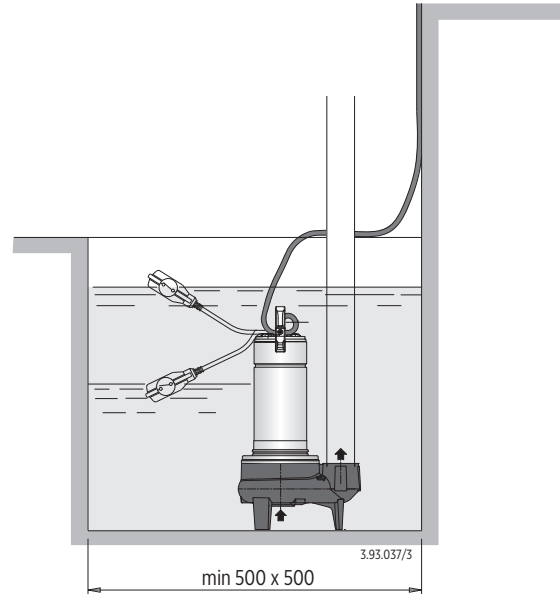
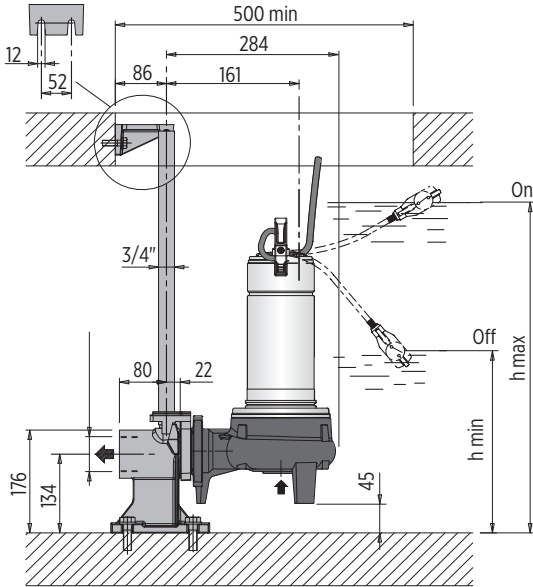

00130021 02/2018

Pump model	EGT	
	Dimensions [mm]	
	h max	h min
EGT 7 (T)	535	275
EGT 9 (T)	560	300
EGT 11 (T)	580	320
EGT 15 T	580	320
EGT 15	610	350

Pump model	EGF	
	Dimensions [mm]	
	h max	h min
EGF 7 (T)	535	275
EGF 9 (T)	560	300
EGF 11 (T)	580	320
EGF 15 T	580	320
EGF 15	610	350

CONNECTION EXAMPLES

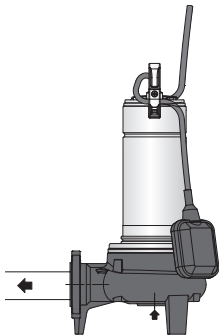

Pump with threaded ports:
pipes screwed into the ports

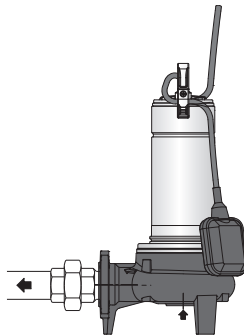

Pump with threaded ports:
pipes with union couplings (locally available)

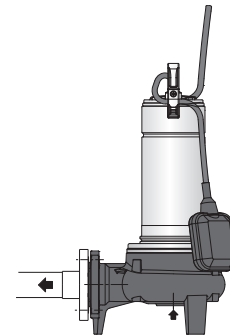

Pump with DN 50 flanged ports:
pipes with counter-flanges

00130122EN 02/2018

EGT/EGF HYDRAULIC PERFORMANCE AT 50 HZ ≈ 2900 1/MIN

Pump model	1x230 V			P ₁	P ₂		Q = Delivery											
	Capacitor				[kW]	[HP]	l/min	50	100	150	200	250	300	350	400	500	550	600
	[A]	[μF]	[Vc]		[kW]	[HP]	0	3	6	9	12	15	18	21	24	30	33	36
EGT/F 7	4.8	16	450	1.1	0.75	1	9.3	8.8	8.3	7.7	7	6.2	5.3	4.3	3.2	2.2	-	-
EGT/F 9	6.6	25	450	1.45	0.9	1.2	11	10.5	10	9.3	8.6	7.8	7	6.2	5.2	4.2	1.8	-
EGT/F 11	8.4	30	450	1.8	1.1	1.5	12.8	12.2	11.6	11	10.3	9.5	8.6	7.7	6.7	5.7	3.3	2
EGT/F 15	12	35	450	2.2	1.5	2	15	14.4	13.7	13	12.2	11.3	10.4	9.5	8.5	7.4	4.5	3.5

P₁ : Max absorbed power

P₂ : Motor nominal power

Density ρ = 1000 Kg/m³

Viscosity kinematic ν = max 20 mm²/sec

Pump model	3x230 V		P ₁	P ₂		Q = Delivery											
	3x400 V			[kW]	[HP]	l/min	50	100	150	200	250	300	350	400	500	550	600
	[A]	[A]		[kW]	[HP]	0	3	6	9	12	15	18	21	24	30	33	36
EGT/F 7 T	3.1	1.8	1.1	0.75	1	9.3	8.8	8.3	7.7	7	6.2	5.3	4.3	3.2	2.2	-	-
EGT/F 9 T	4	2.3	1.45	0.9	1.2	11	10.5	10	9.3	8.6	7.8	7	6.2	5.2	4.2	1.8	-
EGT/F 11 T	5.2	3	1.8	1.1	1.5	12.8	12.2	11.6	11	10.3	9.5	8.6	7.7	6.7	5.7	3.3	2
EGT/F 15 T	6.9	4	2.2	1.5	2	15	14.4	13.7	13	12.2	11.3	10.4	9.5	8.5	7.4	4.5	3.5

P₁ : Max absorbed power

P₂ : Motor nominal power

Density ρ = 1000 Kg/m³

Viscosity kinematic ν = max 20 mm²/sec

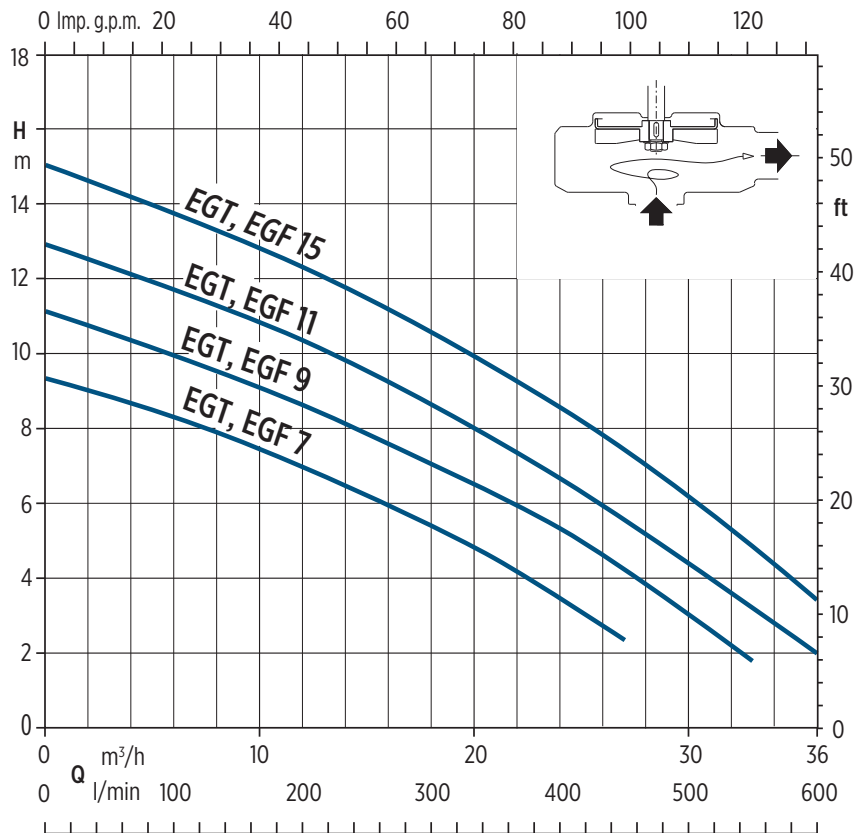

002026 09/2023

FWS-FWC Series - Wastewater lift pumps 50 Hz



FWS-FWC SERIES - WASTEWATER LIFT PUMPS 50 HZ

PUMP IDENTIFICATION CODE

50 | FW... | - | V | - | 5 | 2 | - | 1,8 | T | - | G | - | F

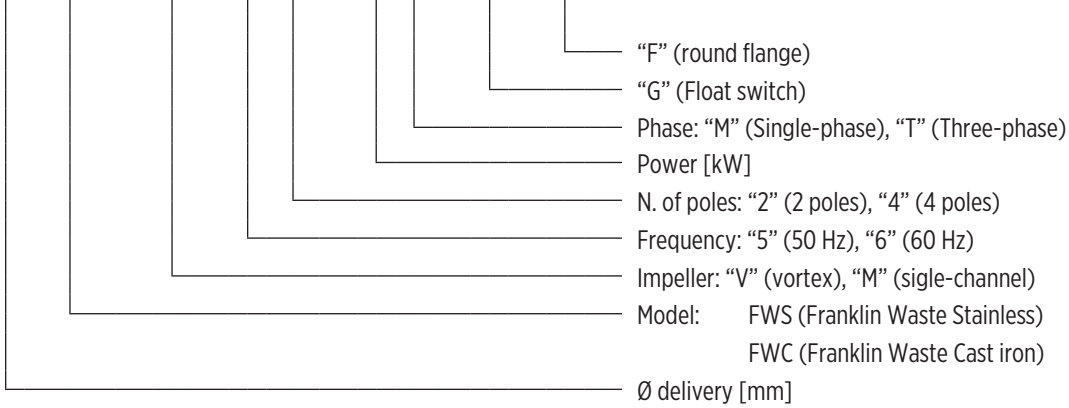

0014006 11/2022



32FWS V SERIES 50 HZ

FEATURES & BENEFITS

APPLICATIONS



Pumping of clear non-loaded fluids



Extraction of water from ponds, streams or pits and for rainwater collection



Wastewater



MARKETS



STAINLESS STEEL AND CAST IRON SUBMERSIBLE WASTEWATER LIFT PUMPS

Submersible electric pump particularly suitable for the emptying of basements, garages, cellars and flooded premises.

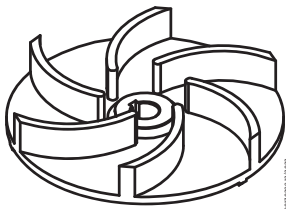

VORTEX IMPELLER

GENERAL FEATURES

Materials/Constr.design		
Vortex impeller		Cast iron EN GJL200
External casing		Stainless steel AISI304
Pump body		Cast iron EN GJL200
Cover		Cast iron EN GJL200
Mechanical seal	motor side	Seal ring
	pump side	Graphite/Alumina
Motor shaft		Stainless steel AISI416
Power cable		10 m H07RN-F type, 3G1 mm ² and SCHUKO plug
Motor		
Constr.design		asynchronous squirrel cage-type oil filled
Type		2 poles; 50 Hz
Insulation class		F
Protection degree		IP68
Voltage	Single-phase	230V ±6% built-in overheating protection, built in capacitor, float switch as optional
Limits of use		
Maximum liquid temperature		+40 °C
pH of pumped liquid		6 - 10
Liquid density		1,0 kg/dm ³
Maximum immersion depth:		5 m
Min. immersion depth for continuous service		250 mm
Free passage		30 mm
Max. number of starting/hour		20
Construction options		

- 60 Hz version
- Different voltages
- Food-grade white oil

DIMENSIONAL DRAWINGS

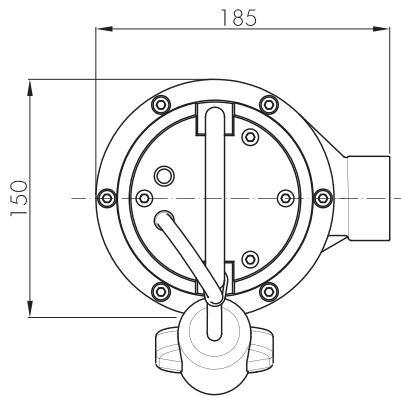
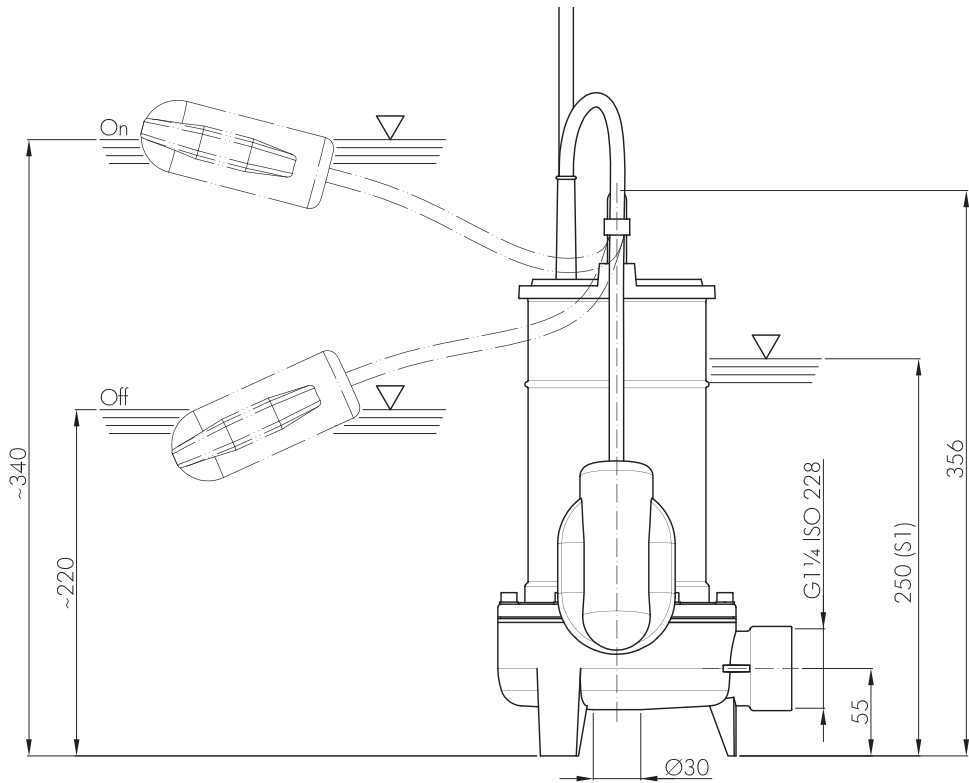

00130276 12/2022

Packaging		
Pump model	Dimensions [mm]	Weight [kg]
32 FWS V	225x180x450	11,5

Pallet		
Dimensions [mm]	N° of pumps	Weight [kg]
1200x800x800	32	400

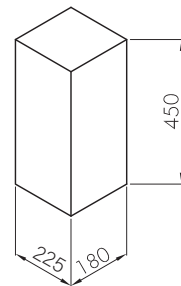
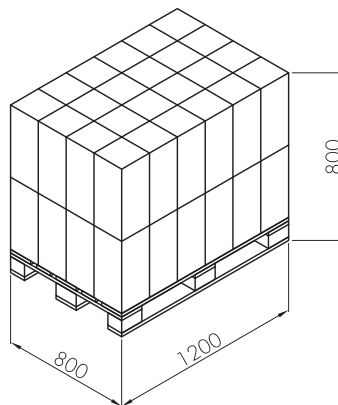

00130288 02/2023

TECHNICAL DATA

Pump model	Motor absorbed power P ₁	Rated power P ₂		Voltage	Rated current	Phase	Power cable		Float switch	Running capacitor	Delivery port	Weight [kg]
	[kW]	[kW]	[HP]	[V]	[A]		Length [m]	Type		[μF]		
32FWS-V-52-0,3M	0,57	0,3	0,4	230	2,8	1~	10	3G1	-	8	G1¼	11
32FWS-V-52-0,3M-G	0,57	0,3	0,4	230	2,8	1~	10	3G1	•	8	G1¼	11

“-” = not available

“•” = available

HYDRAULIC PERFORMANCE AT 50 HZ

Pump model	Phase	Q = Delivery							
		l/sec 0	0,5	1	1,5	2	2,5	3	3,5
		m ³ /h 0	1,8	3,6	5,4	7,2	9	10,8	12,6
		US gpm 0	7,9	15,8	23,7	31,7	39,6	47,5	55,5
		H = Total meters head of water column [m]							
32FWS-V-52-0,3	1~	7,6	6,9	6,3	5,5	4,6	3,5	2,5	1,2

PERFORMANCE CURVES AT 50 HZ

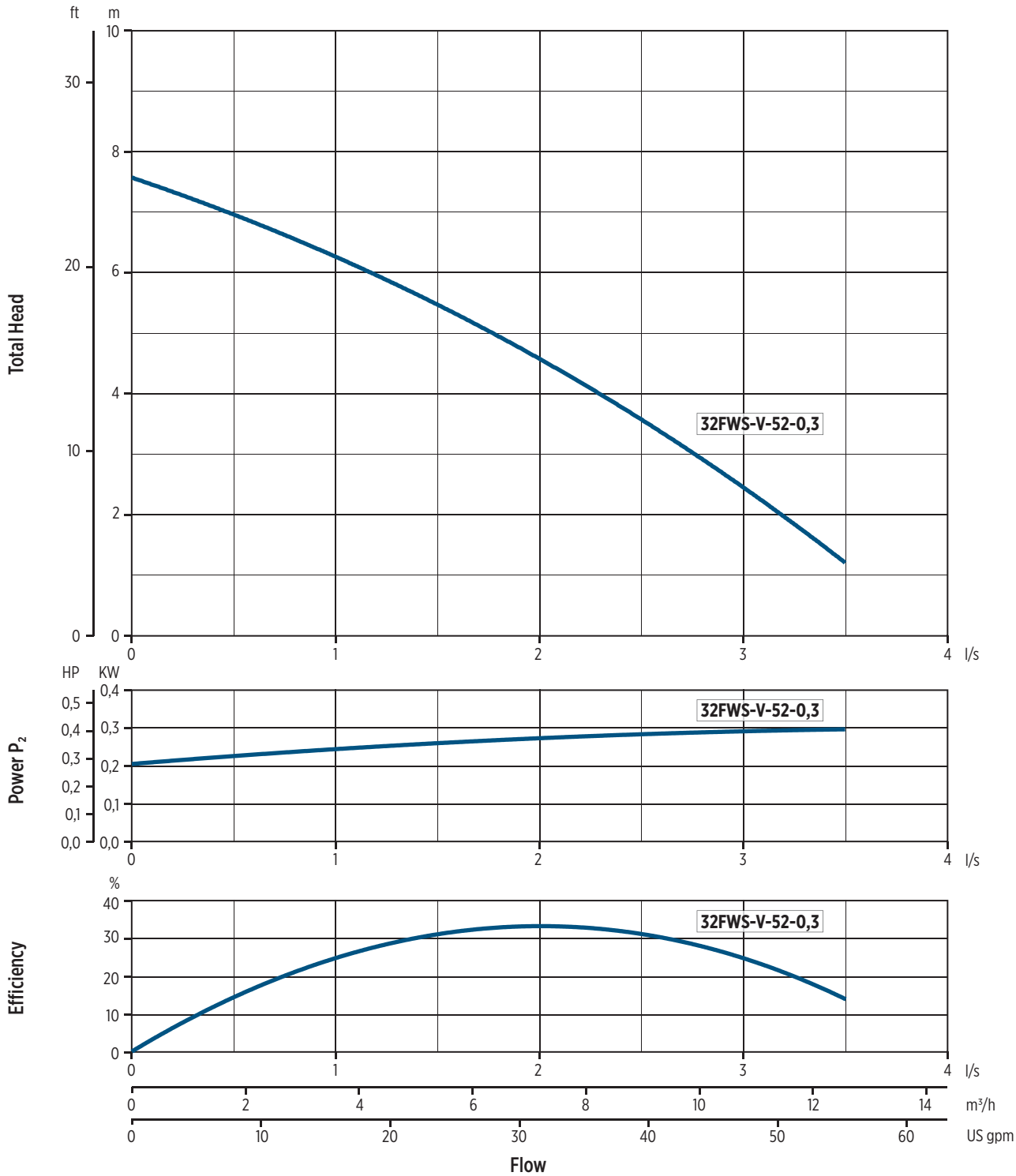

0020092 12/2022

INSTALLATION

INSTALLATION INSTRUCTIONS

TRANSPORTABLE INSTALLATION

Transportable as emergency pump with connection to the hose and for free installation in the well.

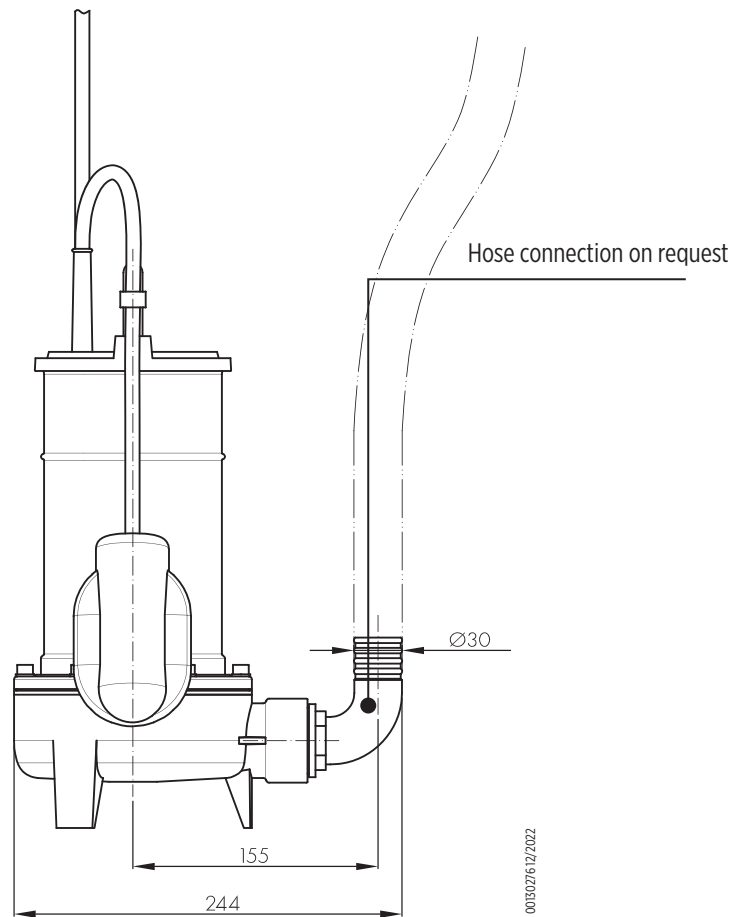

40FWS V SERIES 50 HZ

FEATURES & BENEFITS

APPLICATIONS



Pumping of clear non-loaded fluids



Extraction of water from ponds, streams or pits and for rainwater collection



Wastewater



MARKETS



STAINLESS STEEL AND CAST IRON SUBMERSIBLE WASTEWATER LIFT PUMPS

Submersible electric pump particularly suitable for the emptying of basements, garages, cellars and flooded premises.

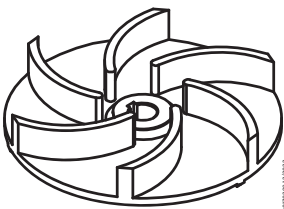

VORTEX IMPELLER

GENERAL FEATURES

		Materials/Constr.design
Vortex impeller		Cast iron EN GJL200
External casing		Stainless steel AISI304
Pump body		Cast iron EN GJL200
Cover		Cast iron EN GJL200
Mechanical seal	motor side	Seal ring
	pump side	Graphite/Alumina
Motor shaft		Stainless steel AISI416
Power cable	Type	10 m H07RN-F type
	Single-phase	3G1mm ² with SCHUKO plug (CEE 7/VII)
	Three-phase	4G1 mm ²
		Motor
Constr.design		asynchronous squirrel cage-type oil filled
Type		2 poles; 50 Hz
Insulation class		F
Protection degree		IP68
Voltage	Single-phase	230 V ±6% built-in overheating protection, built in capacitor, float switch as optional
	Three-phase	230V ±10%, 400V ±10%
		Limits of use
Maximum liquid temperature		+40 °C
pH of pumped liquid		6 - 10
Liquid density		1,0 kg/dm ³
Maximum immersion depth:		5 m
Min. immersion depth for continuous service		280 mm
Free passage		20 mm
Max. number of starting/hour		20
		Construction options

- 60 Hz version
- Different voltages
- Food-grade white oil
- Silicon carbide (SiC/SiC) mechanical seal

DIMENSIONAL DRAWINGS

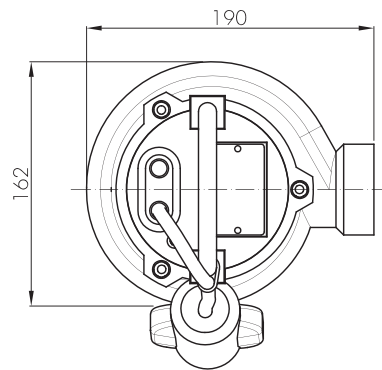
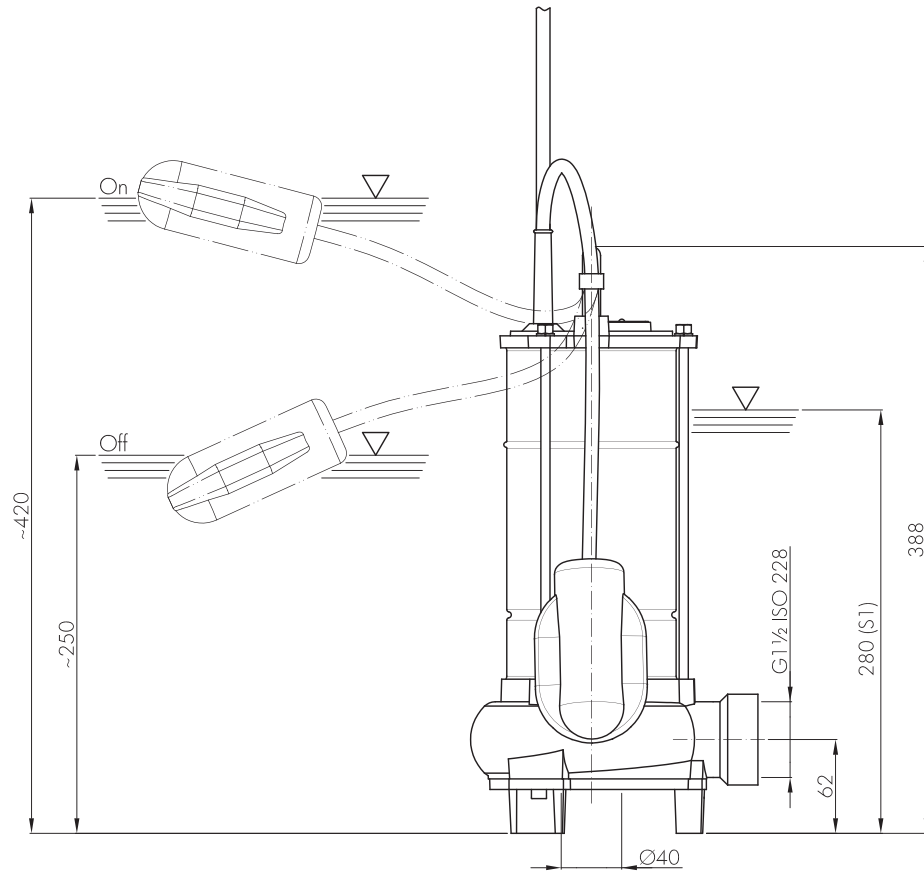

00502712/2022

Packaging		
Pump model	Dimensions [mm]	Weight [kg]
40 FWS V	225x180x450	13,5

Pallet		
Dimensions [mm]	N° of pumps	Weight [kg]
1200x800x800	32	460

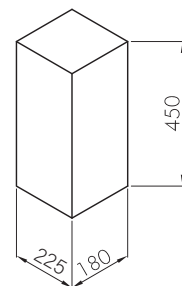
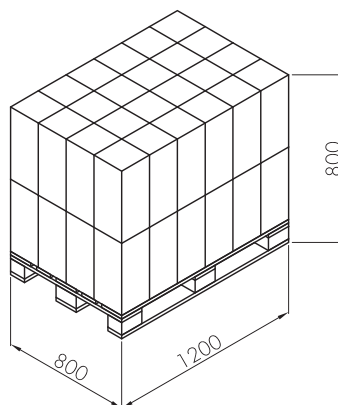

00130288 02/2023

TECHNICAL DATA

Pump model	Motor absorbed power P ₁	Rated power P ₂		Voltage [V]	Rated current [A]	Phase	Power cable		Float switch	Running capacitor [μF]	Delivery port	Weight [kg]
	[kW]	[kW]	[HP]				Length [m]	Type				
40FWS-V-52-0,37M	0,58	0,37	0,5	230	3	1 -	10	3G1	-	8	G1½	13
40FWS-V-52-0,37M-G	0,58	0,37	0,5	230	3	1 -	10	3G1	•	8	G1½	13
40FWS-V-52-0,6M	0,72	0,6	0,8	230	3,7	1 -	10	3G1	-	10	G1½	13
40FWS-V-52-0,6M-G	0,72	0,6	0,8	230	3,7	1 -	10	3G1	•	10	G1½	13
40FWS-V-52-0,7M	0,88	0,7	0,95	230	4,8	1 -	10	3G1	-	14	G1½	14
40FWS-V-52-0,7M-G	0,88	0,7	0,95	230	4,8	1 -	10	3G1	•	14	G1½	14
40FWS-V-52-0,7T	0,88	0,7	0,95	400	1,8	3 -	10	4G1	-	-	G1½	14
40FWS-V-52-0,7T-G	0,88	0,7	0,95	400	1,8	3 -	10	4G1	•	-	G1½	14

“-” = not available

“•” = available

HYDRAULIC PERFORMANCE AT 50 HZ

Pump model	Phase	Q = Delivery											
		l/sec 0	0,5	1	1,5	2	2,5	3	3,5	4	4,5	5	5,5
		m ³ /h 0	1,8	3,6	5,4	7,2	9	10,8	12,6	14,4	16,2	18	19,8
		US gpm 0	7,9	15,8	23,7	31,7	39,6	47,5	55,5	63,4	71,3	79,2	87,2
		H = Total meters head of water column [m]											
40FWS-V-52-0,37	1 -	7	6,5	6	5,2	4,5	3,8	3	2,1				
40FWS-V-52-0,6	1 -	8,1	7,8	7,1	6,8	6,2	5,7	5	4,1	3,3	2,3		
40FWS-V-52-0,7	1 -	9,8	9	8,7	8,1	7,5	6,8	5,9	5	4,2	3,5	2,5	1,5
	3 -	9,8	9	8,7	8,1	7,5	6,8	5,9	5	4,2	3,5	2,5	1,5

PERFORMANCE CURVES AT 50 HZ

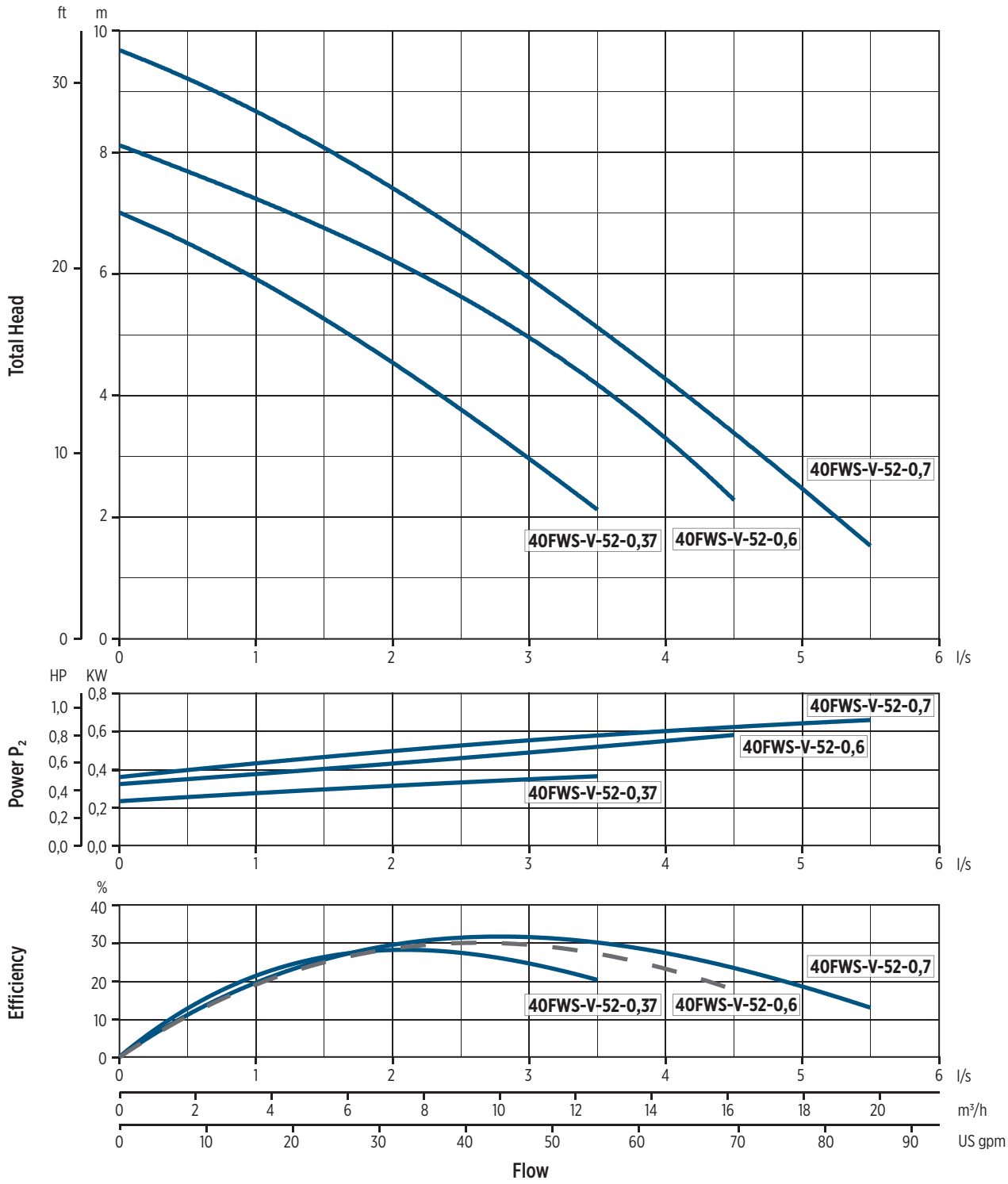

002009312/2022

INSTALLATION

INSTALLATION INSTRUCTIONS

PERMANENT INSTALLATION WITH COUPLING SYSTEM

It is the recommended installation for the permanent pumping station. The electric pump is guided by two pipes and it is connected automatically to the coupling system. The quick connection ensures that the pump can be easily removed and re-installed.

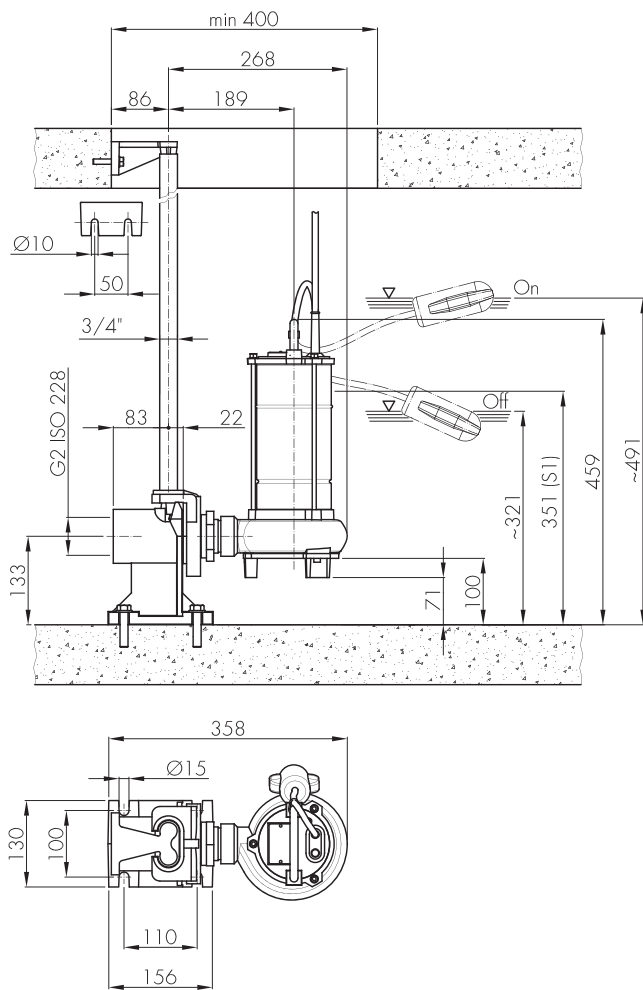

TRANSPORTABLE INSTALLATION

Transportable as emergency pump with connection to the hose and for free installation in the well.

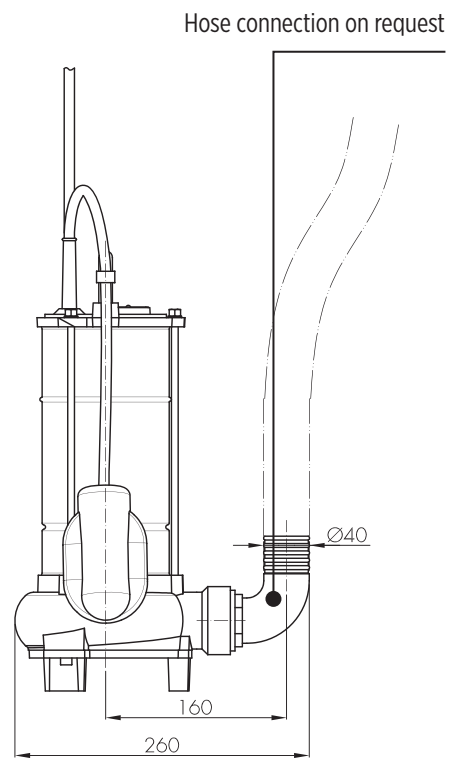

00130271 12/2022

50FWS V SERIES 50 HZ

FEATURES & BENEFITS

APPLICATIONS



Pumping of clear non-loaded fluids



Extraction of water from ponds, streams or pits and for rainwater collection



Wastewater



MARKETS



STAINLESS STEEL AND CAST IRON SUBMERSIBLE WASTEWATER LIFT PUMPS

Submersible electric pump particularly suitable for the emptying of basements, garages, cellars and flooded premises.

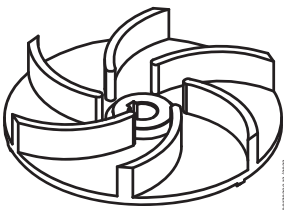

VORTEX IMPELLER

GENERAL FEATURES

		Materials/Constr.design
Vortex impeller		Cast iron EN GJL200
External casing		Stainless steel AISI304
Pump body		Cast iron EN GJL200
Cover		Cast iron EN GJL200
Mechanical seal	motor side	Seal ring
	pump side	Silicon carbide (SiC/SiC)
Motor shaft		Stainless steel AISI416
Power cable	Type	10 m H07RN-F type
	Single-phase	3G1 mm ² with SCHUKO plug (CEE 7/VII)
	Three-phase	4G1 mm ²
		Motor
Constr.design		asynchronous squirrel cage-type in dry chamber
Type		2 poles; 50 Hz
Insulation class		F
Protection degree		IP68
Voltage	Single-phase	230V ±6% built-in overheating protection, built in capacitor, float switch as optional
	Three-phase	230V ±10%, 400V ±10%
		Limits of use
Maximum liquid temperature		+40 °C
pH of pumped liquid		6 - 10
Liquid density		1,0 kg/dm ³
Maximum immersion depth:		5 m
Min. immersion depth for continuous service		375 mm
Free passage		50 mm
Max. number of starting/hour		20
		Construction options

- 60 Hz version
- Different voltages
- External capacitor with 4G1mm² cable

DIMENSIONAL DRAWINGS

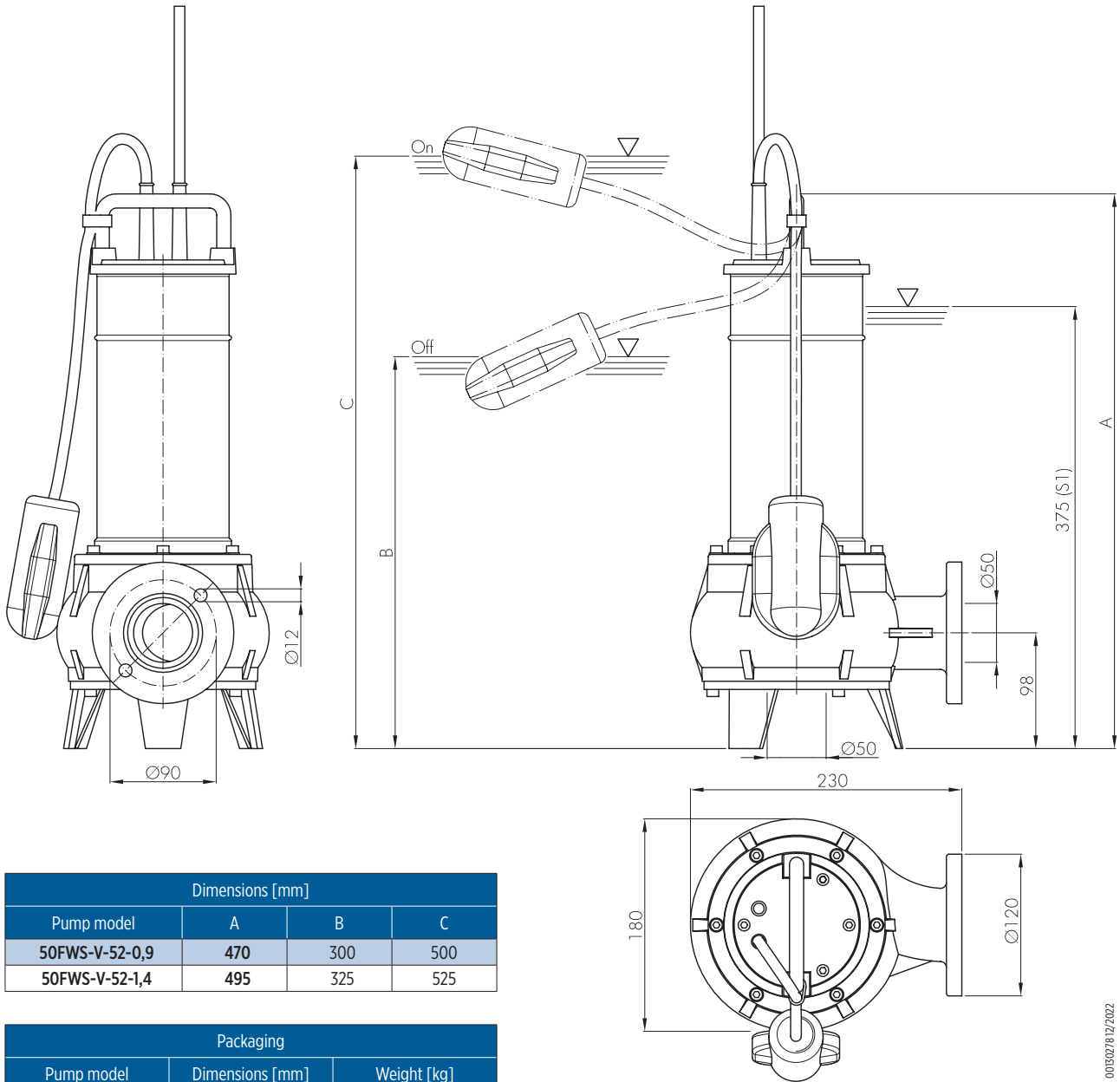

Dimensions [mm]			
Pump model	A	B	C
50FWS-V-52-0,9	470	300	500
50FWS-V-52-1,4	495	325	525

Packaging		
Pump model	Dimensions [mm]	Weight [kg]
50FWS-V-52-0,9	255x205x560	18,7
50FWS-V-52-1,4	255x205x560	19,7

0013027812/2022

TECHNICAL DATA

Pump model	Motor absorbed power P ₁	Rated power P ₂		Voltage [V]	Rated current [A]	Phase	Power cable		Float switch	Running capacitor [μF]	Delivery port	Weight [kg]
	[kW]	[kW]	[HP]				Length [m]	Type				
50FWS-V-52-0,9M	1,3	0,9	1,2	230	6	1 -	10	3G1	-	20	G2	18
50FWS-V-52-0,9M-F	1,3	0,9	1,2	230	6	1 -	10	3G1	-	20	Ø50	18
50FWS-V-52-0,9M-G	1,3	0,9	1,2	230	6	1 -	10	3G1	•	20	G2	18
50FWS-V-52-0,9M-G-F	1,3	0,9	1,2	230	6	1 -	10	3G1	•	20	Ø50	18
50FWS-V-52-0,9T	1,3	0,9	1,2	400	2	3 -	10	4G1	-	-	G2	18
50FWS-V-52-0,9T-F	1,3	0,9	1,2	400	2	3 -	10	4G1	-	-	Ø50	18
50FWS-V-52-0,9T-G	1,3	0,9	1,2	400	2	3 -	10	4G1	•	-	G2	18
50FWS-V-52-0,9T-G-F	1,3	0,9	1,2	400	2	3 -	10	4G1	•	-	Ø50	18
50FWS-V-52-1,4M	1,7	1,4	1,9	230	7,7	1 -	10	3G1	-	25	G2	19
50FWS-V-52-1,4M-F	1,7	1,4	1,9	230	7,7	1 -	10	3G1	-	25	Ø50	19
50FWS-V-52-1,4M-G	1,7	1,4	1,9	230	7,7	1 -	10	3G1	•	25	G2	19
50FWS-V-52-1,4M-G-F	1,7	1,4	1,9	230	7,7	1 -	10	3G1	•	25	Ø50	19
50FWS-V-52-1,4T	1,7	1,4	1,9	400	3,2	3 -	10	4G1	-	-	G2	19
50FWS-V-52-1,4T-F	1,7	1,4	1,9	400	3,2	3 -	10	4G1	-	-	Ø50	19

"-" = not available

• = available

HYDRAULIC PERFORMANCE AT 50 HZ

Pump model	Phase	Q = Delivery														
		l/sec 0	1	1,5	2	2,5	3	3,5	4	4,5	5	6	7	8	9	10
		m ³ /h 0	3,6	5,4	7,2	9	10,8	12,6	14,4	16,2	18	21,6	25,2	28,8	32,4	36
		US gpm 0	15,8	23,7	31,7	39,6	47,5	55,5	63,4	71,3	79,2	92,1	110,9	126,8	142,6	158,5
		H = Total meters head of water column [m]														
50FWS-V-52-0,9	1 -	11	10,3	9,9	9,4	8,9	8,5	7,9	7,4	6,8	6,2	4,9	3,7	2,3	1,2	
	3 -	11	10,3	9,9	9,4	8,9	8,5	7,9	7,4	6,8	6,2	4,9	3,7	2,3	1,2	
50FWS-V-52-1,4	1 -	12	11,5	11,2	10,8	10,5	10,1	9,7	9,2	8,6	8	6,7	5,4	4	2,7	1,3
	3 -	12	11,5	11,2	10,8	10,5	10,1	9,7	9,2	8,6	8	6,7	5,4	4	2,7	1,3

HYDRAULIC PERFORMANCE AT 50 HZ

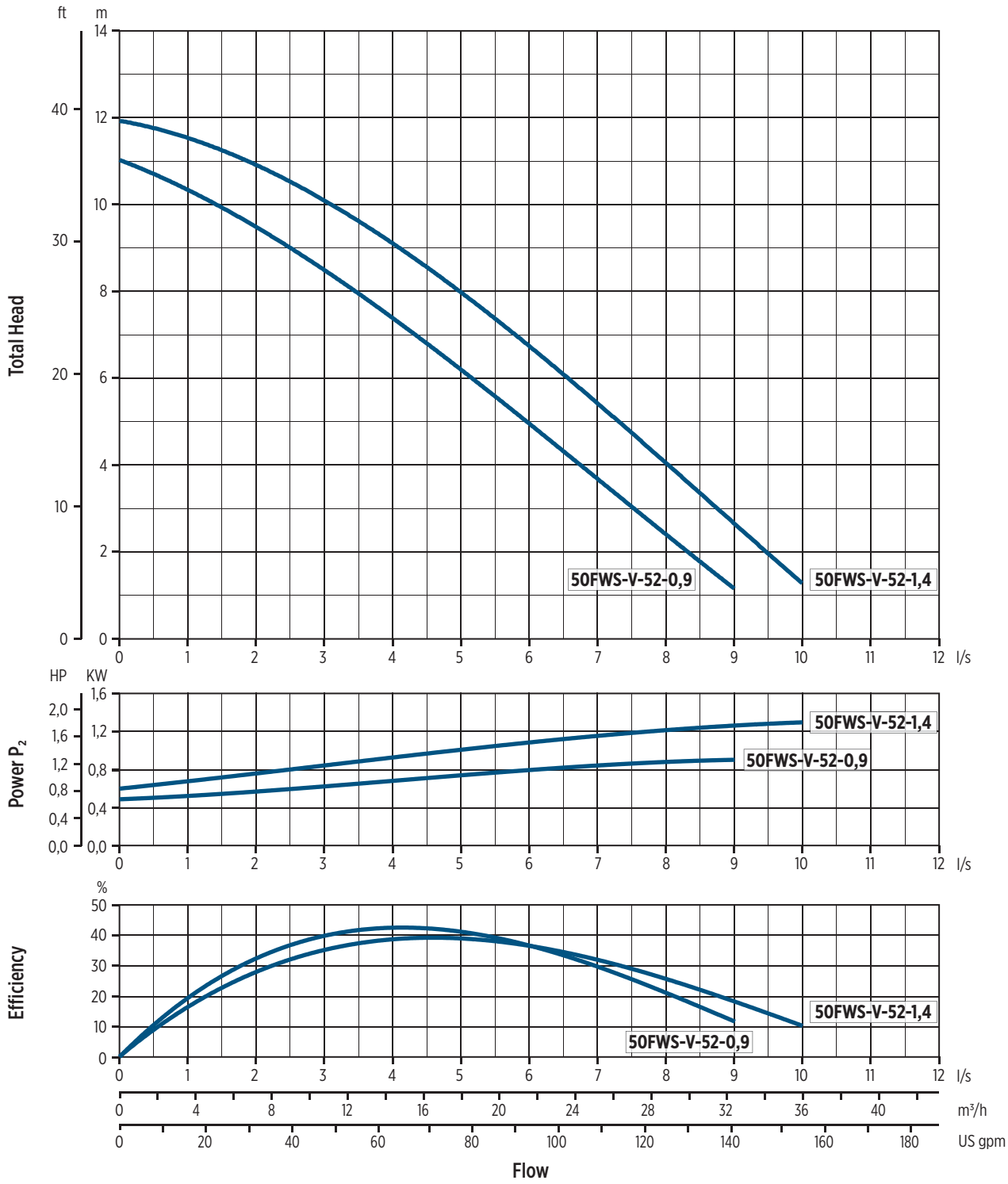

0020094.12/2022

INSTALLATION

INSTALLATION INSTRUCTIONS

PERMANENT INSTALLATION WITH COUPLING SYSTEM

It is the recommended installation for the permanent pumping station. The electric pump is guided by two pipes and it is connected automatically to the coupling system. The quick connection ensures that the pump can be easily removed and re-installed.

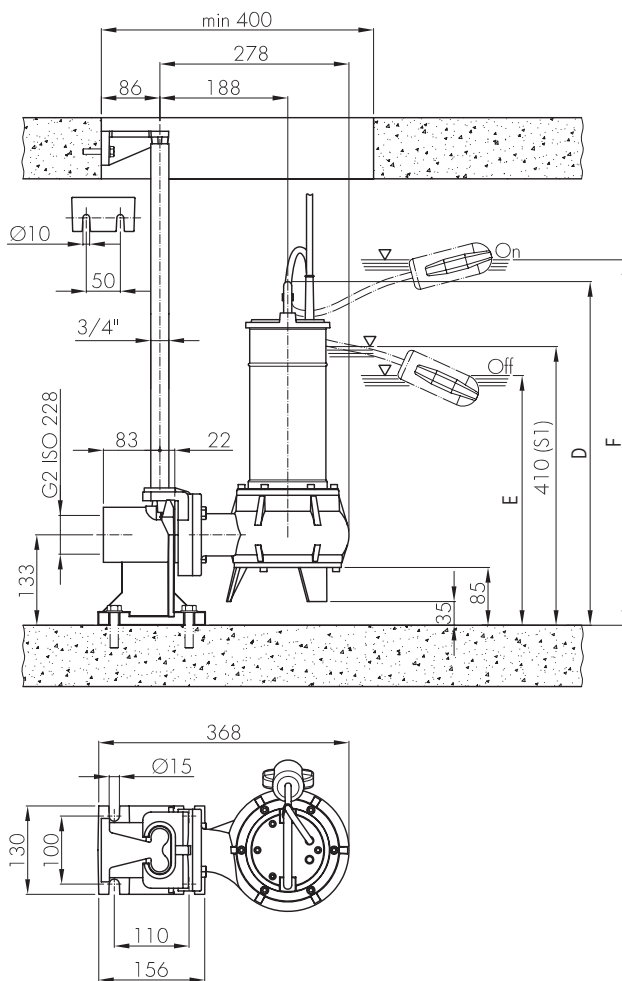

TRANSPORTABLE INSTALLATION

Transportable as emergency pump with connection to the hose and for free installation in the well.

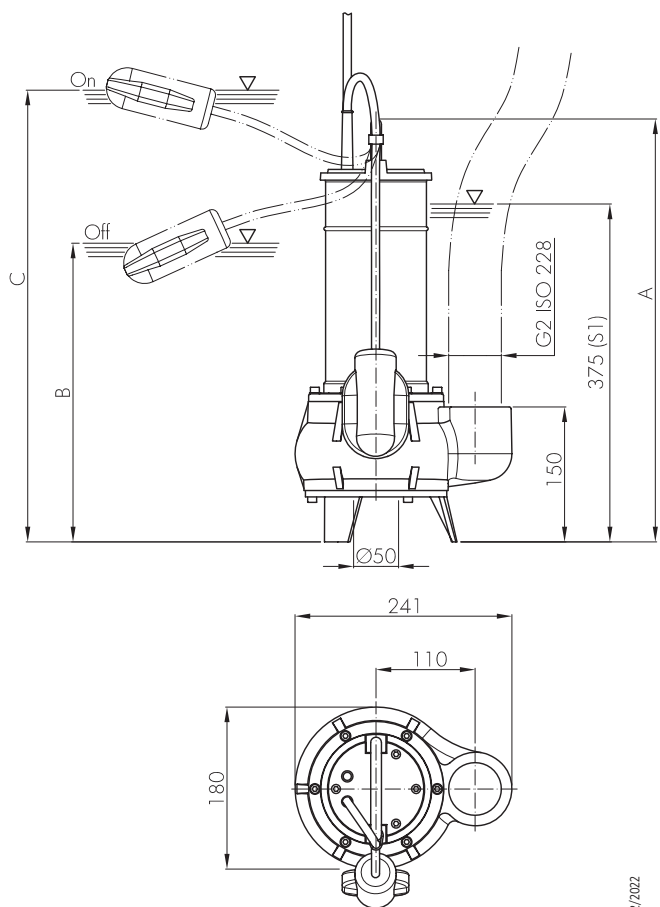

0030278 12/2022

Installation Dimensions [mm]

Pump model	A	B	C	D	E	F
50FWS-V-52-0,9	470	300	500	505	335	535
50FWS-V-52-1,4	495	325	525	530	360	560

50FWC V SERIES 50 HZ

FEATURES & BENEFITS

APPLICATIONS



Pumping of clear non-loaded fluids



Extraction of water from ponds, streams or pits and for rainwater collection



Wastewater



MARKETS



CAST IRON SUBMERSIBLE WASTEWATER LIFT PUMPS

Submersible electric pumps suitable for pumping screened waste water, draining the sewage of blocks of flats and houses and flooded premises in general.

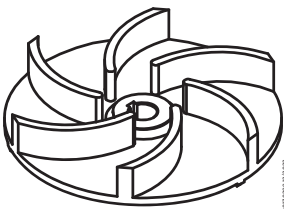

VORTEX IMPELLER

GENERAL FEATURES

		Materials/Constr.design
Vortex impeller		Cast iron EN GJL200
External casing		Cast iron EN GJL200
Pump body		Cast iron EN GJL200
Cover		Cast iron EN GJL200
Mechanical seal		Silicon carbide (SiC/SiC)
Motor shaft		Stainless steel AISI416
Power cable	Type	10 m H07RN-F type
	Single-phase	4G1,5mm ² , capacitor box and SCHUKO plug (CEE 7/VII)
	Single-phase 50FWC-V-52-1,6M	4G2,5mm ² , capacitor box and SCHUKO plug (CEE 7/VII)
	Three-phase	4G1,5mm ²
		Motor
Constr.design		asynchronous squirrel cage-type oil filled
Type		2 poles; 50 Hz
Insulation class		F
Protection degree		IP68
Voltage	Single-phase	230V ±6% built-in overheating protection (up to 1,1 kW), float switch as optional capacitor box and SCHUKO plug (CEE 7/VII)
	Three-phase	230V ±10%, 400V ±10%
		Limits of use
Maximum liquid temperature		+40 °C
pH of pumped liquid		6 - 10
Liquid density		1,0 kg/dm ³
Maximum immersion depth:		5 m
Min. immersion depth for continuous service		
50FWC-V-52-0,9M/T, 50FWC-V-52-1,1M/T		353 mm
50FWC-V-52-1,6M/T		380 mm
Free passage	50FWC-V-52-0,9M/T, 50FWC-V-52-1,1M/T	40 mm
	50FWC-V-52-1,6M/T	50 mm
Max. number of starting/hour		20
		Construction options

- 60 Hz version
- Different voltages
- Food-grade white oil

DIMENSIONAL DRAWINGS

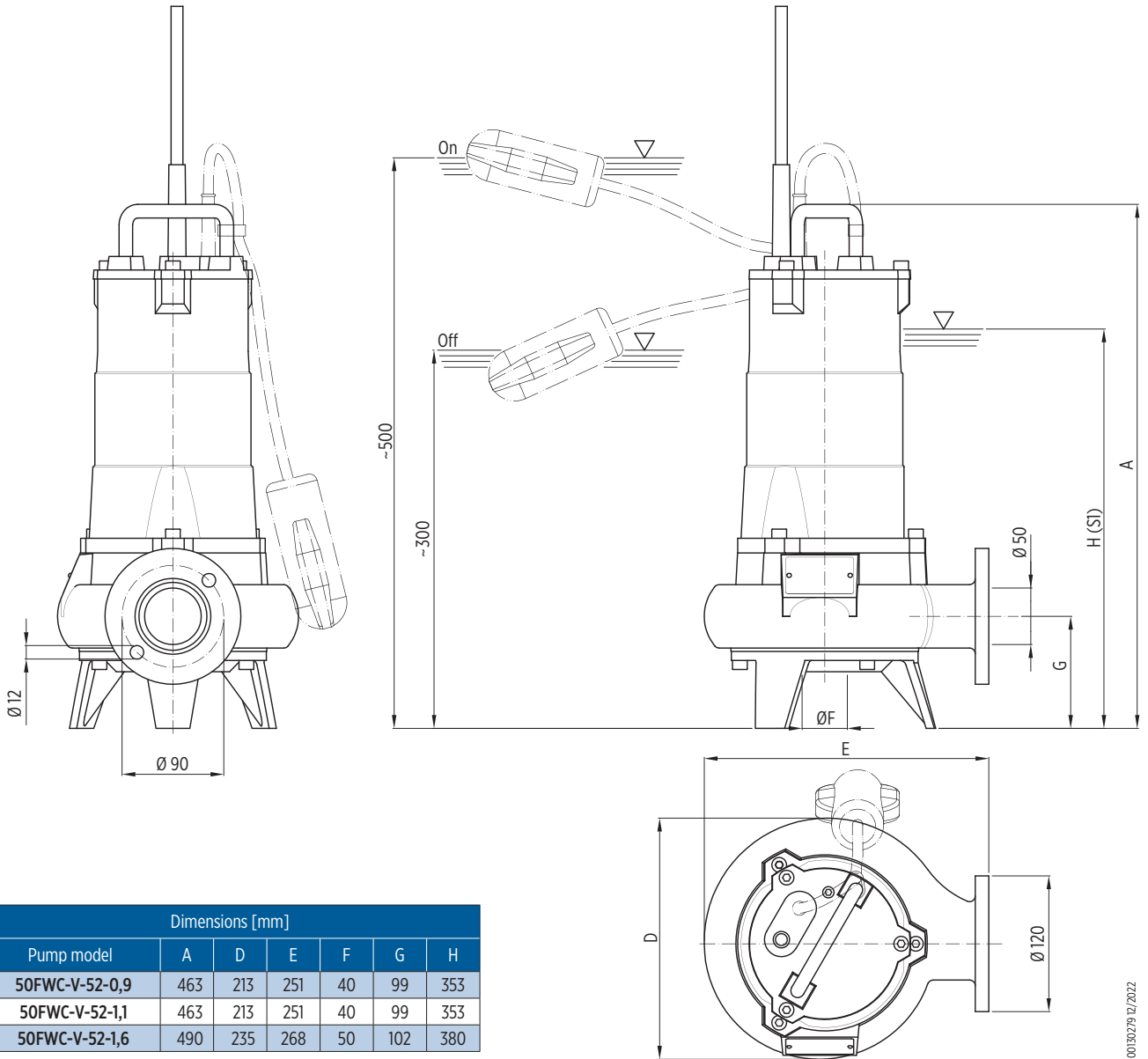

Dimensions [mm]						
Pump model	A	D	E	F	G	H
50FWC-V-52-0,9	463	213	251	40	99	353
50FWC-V-52-1,1	463	213	251	40	99	353
50FWC-V-52-1,6	490	235	268	50	102	380

Packaging		
Pump model	Dimensions [mm]	Weight [kg]
50FWC-V-52-0,9	290x245x585	30
50FWC-V-52-1,1	290x245x585	30
50FWC-V-52-1,6	300x260x585	36

00130279 12/2022

TECHNICAL DATA

Pump model	Motor absorbed power P ₁	Rated power P ₂		Voltage	Rated current	Phase	Power cable		Float switch	Running capacitor	Delivery port	Weight [kg]
	[kW]	[kW]	[HP]	[V]	[A]		Length [m]	Type		[μF]		
50FWC-V-52-0,9M	1,3	0,9	1,2	230	5,8	1 -	10	4G1,5	-	25	G2 (Ø50)	29
50FWC-V-52-0,9M-G	1,3	0,9	1,2	230	5,8	1 -	10	4G1,5	•	25	G2 (Ø50)	29
50FWC-V-52-0,9T	1,3	0,9	1,2	400	2	3 -	10	4G1,5	-	-	G2 (Ø50)	29
50FWC-V-52-0,9T-G	1,3	0,9	1,2	400	2	3 -	10	4G1,5	•	-	G2 (Ø50)	29
50FWC-V-52-1,1M	1,7	1,1	1,5	230	7	1 -	10	4G1,5	-	30	G2 (Ø50)	29
50FWC-V-52-1,1M-G	1,7	1,1	1,5	230	7	1 -	10	4G1,5	•	30	G2 (Ø50)	29
50FWC-V-52-1,1T	1,7	1,1	1,5	400	3	3 -	10	4G1,5	-	-	G2 (Ø50)	29
50FWC-V-52-1,1T-G	1,7	1,1	1,5	400	3	3 -	10	4G1,5	•	-	G2 (Ø50)	29
50FWC-V-52-1,6M	2,3	1,6	2,1	230	9,1	1 -	10	4G2,5	-	40	G2 (Ø50)	35
50FWC-V-52-1,6M-G	2,3	1,6	2,1	230	9,1	1 -	10	4G2,5	•	40	G2 (Ø50)	35
50FWC-V-52-1,6T	2,3	1,6	2,1	400	4	3 -	10	4G1,5	-	-	G2 (Ø50)	35
50FWC-V-52-1,6T-G	2,3	1,6	2,1	400	4	3 -	10	4G1,5	•	-	G2 (Ø50)	35

"-" = not available

• = available

HYDRAULIC PERFORMANCE AT 50 HZ

Pump model	Phase	Q = Delivery										
		l/sec 0	1	2	3	4	5	6	7	8	9	10
		m ³ /h 0	3,6	7,2	10,8	14,4	18	21,6	25,2	28,8	32,4	36
		US gpm 0	15,8	31,7	47,5	63,4	79,2	92,1	110,9	126,8	142,6	158,5
H = Total meters head of water column [m]												
50FWC-V-52-0,9	1 -	12,2	11	9,8	8,5	7,4	6	4,3	2,3			
	3 -	12,2	11	9,8	8,5	7,4	6	4,3	2,3			
50FWC-V-52-1,1	1 -	13	12	11	9,5	8,3	7	5,7	4,4	3	1,6	
	3 -	13	12	11	9,5	8,3	7	5,7	4,4	3	1,6	
50FWC-V-52-1,6	1 -	14	12,5	11,5	10,5	9,6	8,7	7,8	6,8	5,5	4	2,1
	3 -	14	12,5	11,5	10,5	9,6	8,7	7,8	6,8	5,5	4	2,1

HYDRAULIC PERFORMANCE AT 50 HZ

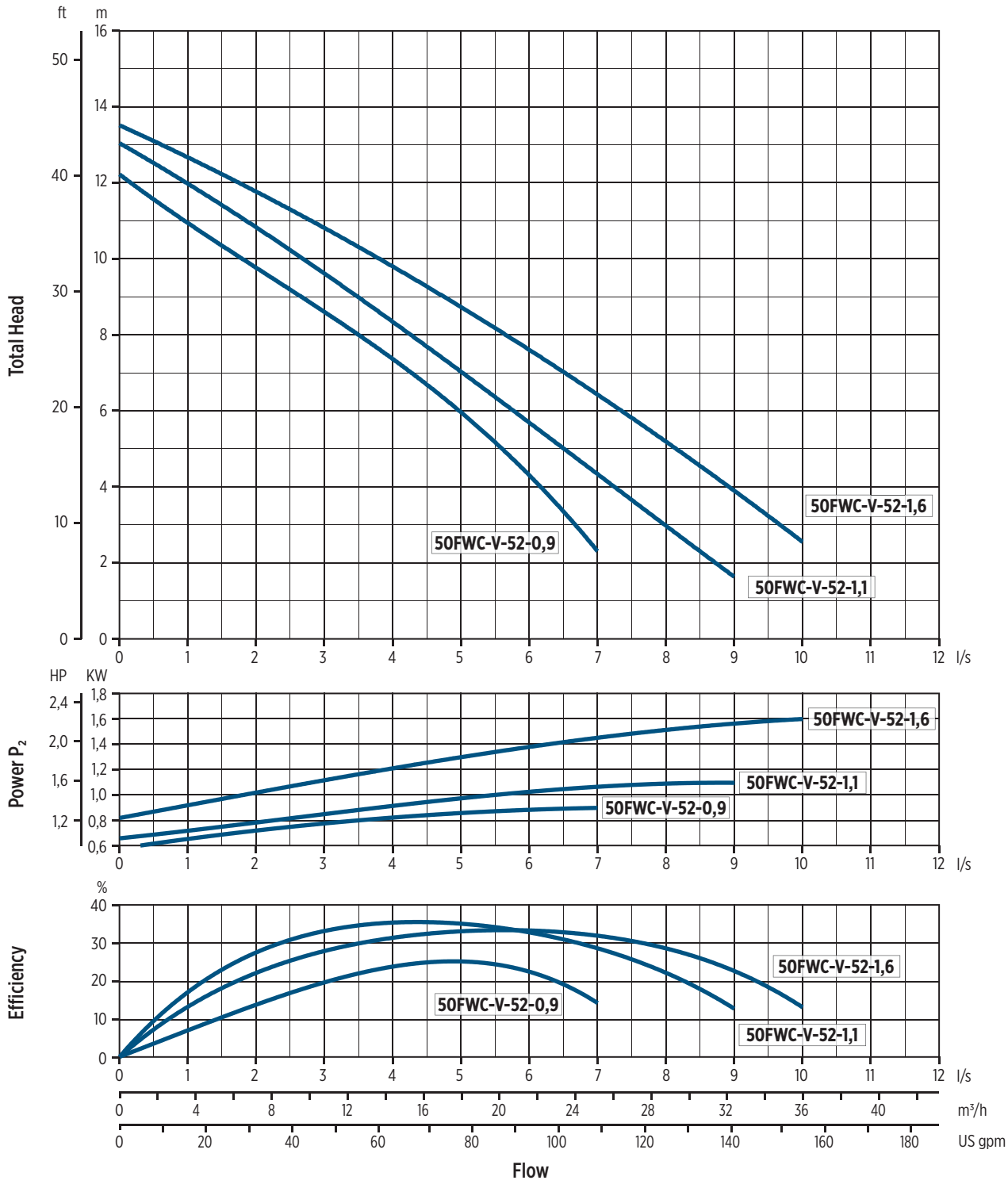

0020095 12/2022

INSTALLATION

INSTALLATION INSTRUCTIONS

PERMANENT INSTALLATION WITH COUPLING SYSTEM

It is the recommended installation for the permanent pumping station. The electric pump is guided by two pipes and it is connected automatically to the coupling system. The quick connection ensures that the pump can be easily removed and re-installed.

TRANSPORTABLE INSTALLATION

Transportable as emergency pump with connection to the hose and for free installation in the well.

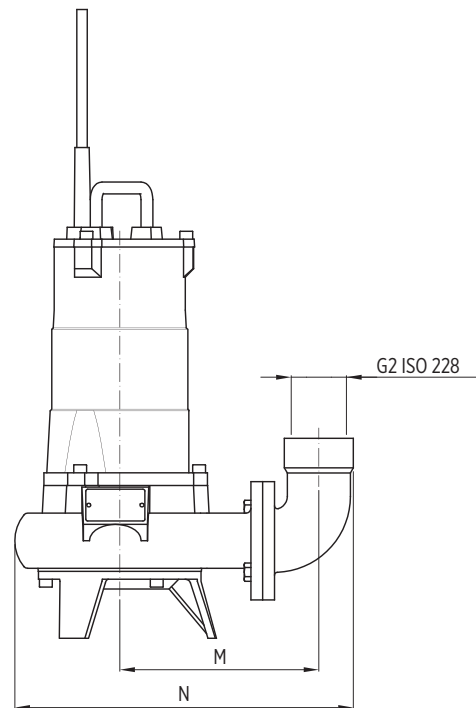
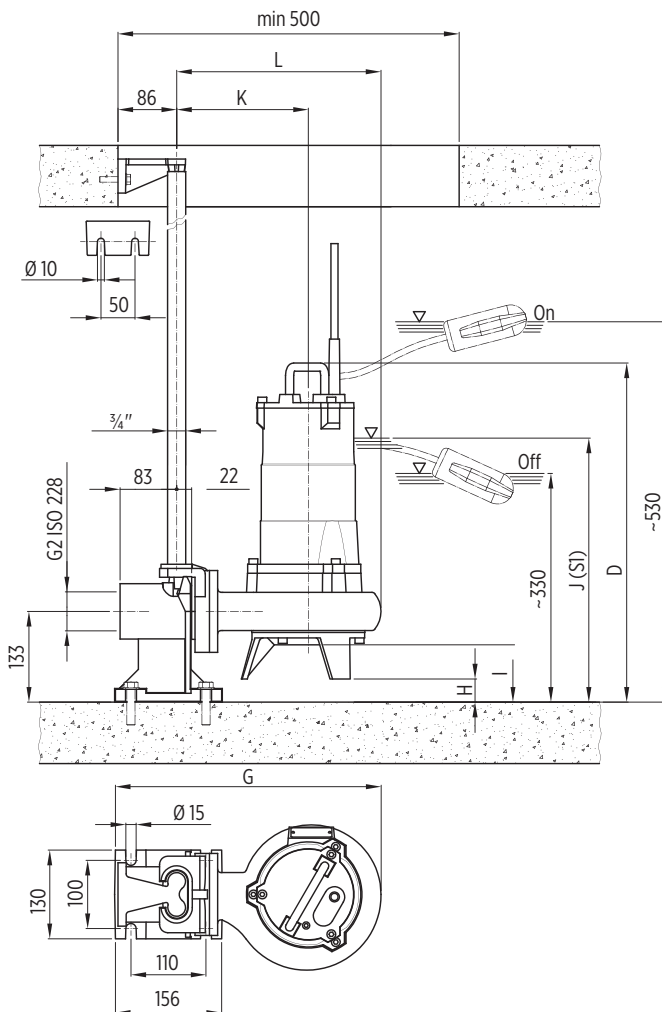

00130279/12/2022

Installation Dimensions [mm]

Pump model	D	G	H	I	J	K	L	M	N
50FWC-V-52-0,9	497	390	34	84	387	193	300	202	344
50FWC-V-52-1,1	497	390	34	84	387	193	300	202	344
50FWC-V-52-1,6	521	407	31	81	414	200	316	209	360

50FWC M SERIES 50 HZ

FEATURES & BENEFITS

APPLICATIONS



Pumping of clear non-loaded fluids



Extraction of water from ponds, streams or pits and for rainwater collection



Wastewater



MARKETS



CAST IRON SUBMERSIBLE WASTEWATER LIFT PUMPS

Submersible electric pumps suitable for pumping screened waste water, draining the sewage of blocks of flats and houses and flooded premises in general.

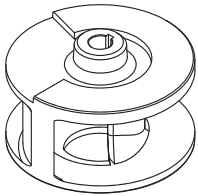

SINGLE-CHANNEL IMPELLER

GENERAL FEATURES

		Materials/Constr.design
Vortex impeller		Cast iron EN GJL200
Pump body		Cast iron EN GJL200
External casing		Cast iron EN GJL200
Cover		Cast iron EN GJL200
Mechanical seal		Silicon carbide (SiC/SiC)
Motor shaft		Stainless steel AISI416
Power cable	Type	10 m H07RN-F type
	Single-phase	4G1,5mm ² , capacitor box and SCHUKO plug (CEE 7/VII)
	Single-phase 50FWC-M-52-1,6M	4G2,5mm ² , capacitor box and SCHUKO plug (CEE 7/VII)
	Three-phase	4G1,5mm ²
		Motor
Constr.design		asynchronous squirrel cage-type oil filled
Type		2 poles; 50 Hz
Insulation class		F
Protection degree		IP68
Voltage	Single-phase	230V ±6% built-in overheating protection, float switch as optional capacitor box and SCHUKO plug (CEE 7/VII)
	Three-phase	230V ±10%, 400V ±10%
		Limits of use
Maximum liquid temperature		+40 °C
pH of pumped liquid		6 - 10
Liquid density		1,0 kg/dm ³
Maximum immersion depth:		5 m
Min. immersion depth for continuous service		
50FWC-M-52-0,9M/T, 50FWC-M-52-1,1M/T		353 mm
50FWC-M-52-1,6M/T, 50FWC-M-52-1,6T-HH		380 mm
Free passage	50FWC-M-52-0,9M/T, 50FWC-M-52-1,1M/T	40 mm
	50FWC-M-52-1,6M/T, 50FWC-M-52-1,6T-HH	50 mm
Max. number of starting/hour		20
		Construction options

- 60 Hz version
- Different voltages
- Food-grade white oil

DIMENSIONAL DRAWINGS

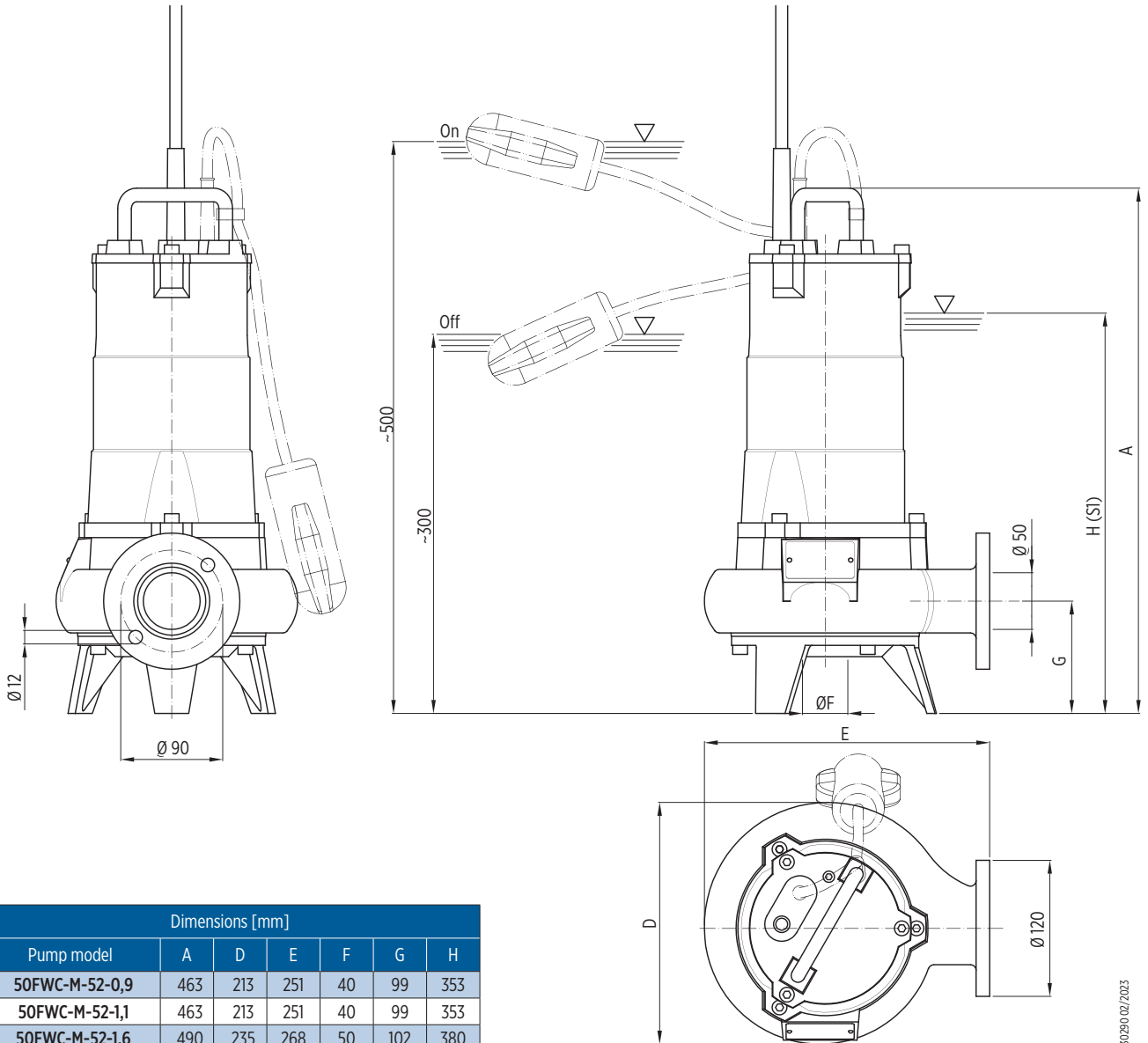

00150290 02/2023

Dimensions [mm]

Pump model	A	D	E	F	G	H
50FWC-M-52-0,9	463	213	251	40	99	353
50FWC-M-52-1,1	463	213	251	40	99	353
50FWC-M-52-1,6	490	235	268	50	102	380

Packaging

Pump model	Dimensions [mm]	Weight [kg]
50FWC-M-52-0,9	290x245x585	31
50FWC-M-52-1,1	290x245x585	31
50FWC-M-52-1,6	300x260x585	35

TECHNICAL DATA

Pump model	Motor absorbed power P_1	Rated power P_2		Voltage	Rated current	Phase	Power cable		Float switch	Running capacitor	Delivery port	Weight [kg]
	[kW]	[kW]	[HP]	[V]	[A]		Length [m]	Type		[μ F]		
50FWC-M-52-0,9M	1,3	0,9	1,2	230	5,8	1 -	10	4G1,5	-	25	G2 (Ø50)	30
50FWC-M-52-0,9M-G	1,3	0,9	1,2	230	5,8	1 -	10	4G1,5	•	25	G2 (Ø50)	30
50FWC-M-52-0,9T	1,3	0,9	1,2	400	2	3 -	10	4G1,5	-	-	G2 (Ø50)	30
50FWC-M-52-0,9T-G	1,3	0,9	1,2	400	2	3 -	10	4G1,5	•	-	G2 (Ø50)	30
50FWC-M-52-1,1M	1,7	1,1	1,5	230	7	1 -	10	4G1,5	-	30	G2 (Ø50)	30
50FWC-M-52-1,1M-G	1,7	1,1	1,5	230	7	1 -	10	4G1,5	•	30	G2 (Ø50)	30
50FWC-M-52-1,1T	1,6	1,1	1,5	400	3	3 -	10	4G1,5	-	-	G2 (Ø50)	30
50FWC-M-52-1,1T-G	1,6	1,1	1,5	400	3	3 -	10	4G1,5	•	-	G2 (Ø50)	30
50FWC-M-52-1,6M	2,3	1,6	2,1	230	11	1 -	10	4G2,5	-	40	G2 (Ø50)	34
50FWC-M-52-1,6M-G	2,3	1,6	2,1	230	11	1 -	10	4G2,5	•	40	G2 (Ø50)	34
50FWC-M-52-1,6T	2,2	1,6	2,1	400	4	3 -	10	4G1,5	-	-	G2 (Ø50)	34
50FWC-M-52-1,6T-HH	2,2	1,6	2,1	400	4,2	3 -	10	4G1,5	-	-	G2 (Ø50)	34
50FWC-M-52-1,6T-G	2,2	1,6	2,1	400	4	3 -	10	4G1,5	•	-	G2 (Ø50)	34

"-" = not available

• = available

HYDRAULIC PERFORMANCE AT 50 HZ

Pump model	Phase	Q = Delivery													
		l/sec 0	1	2	3	4	5	6	7	8	9	10	12	13	14
		m ³ /h 0	3,6	7,2	10,8	14,4	18	21,6	25,2	28,8	32,4	36	43,2	46,8	50,4
		US gpm 0	15,8	31,7	47,5	63,4	79,2	92,1	110,9	126,8	142,6	158,5	190,2	206	221,9
		H = Total meters head of water column [m]													
50FWC-M-52-0,9	1 -	15,5	12,5	11	9,5	8,3	7	5,6	4,1	2,5					
	3 -	15,5	12,5	11	9,5	8,3	7	5,6	4,1	2,5					
50FWC-M-52-1,1	1 -	17,5	15	13,5	12	10,5	9,4	8	6,5	5	3,4	1,7			
	3 -	17,5	15	13,5	12	10,5	9,4	8	6,5	5	3,4	1,7			
50FWC-M-52-1,6	1 -	19	17	15,5	14	13	12	11	10	9,4	8,6	7,7	5,8	4,2	2,5
	3 -	19	17	15,5	14	13	12	11	10	9,4	8,6	7,7	5,8	4,2	2,5
	3 - HH	24	22	20,5	19	17,5	16,5	15,2	14	13					

HYDRAULIC PERFORMANCE AT 50 HZ

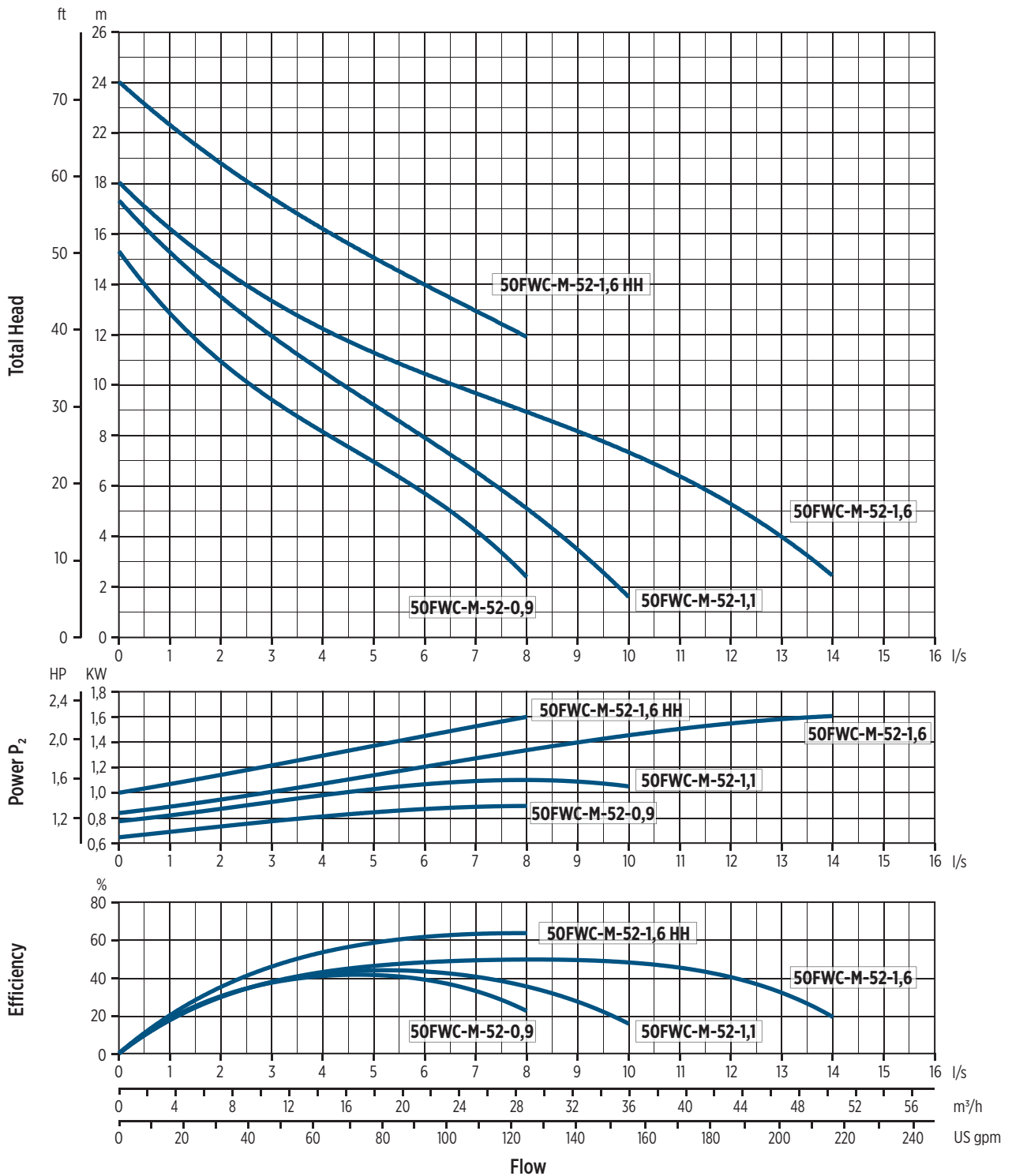

0020105 02/2023

50FWC V4 SERIES 50 HZ

FEATURES & BENEFITS

APPLICATIONS



Pumping of clear non-loaded fluids



Extraction of water from ponds, streams or pits and for rainwater collection



Wastewater



MARKETS



CAST IRON SUBMERSIBLE WASTEWATER LIFT PUMPS

Submersible electric pumps suitable for pumping screened waste water, draining the sewage of blocks of flats and houses and flooded premises in general.

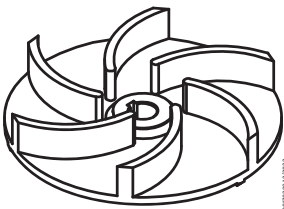

VORTEX IMPELLER

GENERAL FEATURES

		Materials/Constr.design
Vortex impeller		Cast iron EN GJL200
Pump body		Cast iron EN GJL200
External casing		Cast iron EN GJL200
Cover		Cast iron EN GJL200
Mechanical seal		Silicon carbide (SiC/SiC)
Motor shaft		Stainless steel AISI416
Power cable	Type	10 m H07RN-F type
	Single-phase	4G1,5mm ² , capacitor box and SCHUKO plug (CEE 7/VII)
	Three-phase	4G1,5mm ²
		Motor
Constr.design		asynchronous squirrel cage-type oil filled
Type		4 poles; 50 Hz
Insulation class		F
Protection degree		IP68
Voltage	Single-phase	230V ±6% built-in overheating protection (up to 1,1 kW), float switch as optional capacitor box and SCHUKO plug (CEE 7/VII)
	Three-phase	230V ±10%, 400V ±10%
		Limits of use
Maximum liquid temperature		+40 °C
pH of pumped liquid		6 - 10
Liquid density		1,0 kg/dm ³
Maximum immersion depth:		5 m
Min. immersion depth for continuous service		
50FWC-V-54-0,75M/T		353 mm
50FWC-V-54-1,1M/T		380 mm
Free passage	50FWC-V-54-0,75M/T	40 mm
	50FWC-V-54-1,1M/T	50 mm
Max. number of starting/hour		20
		Construction options

- 60 Hz version
- Different voltages
- Food-grade white oil

DIMENSIONAL DRAWINGS

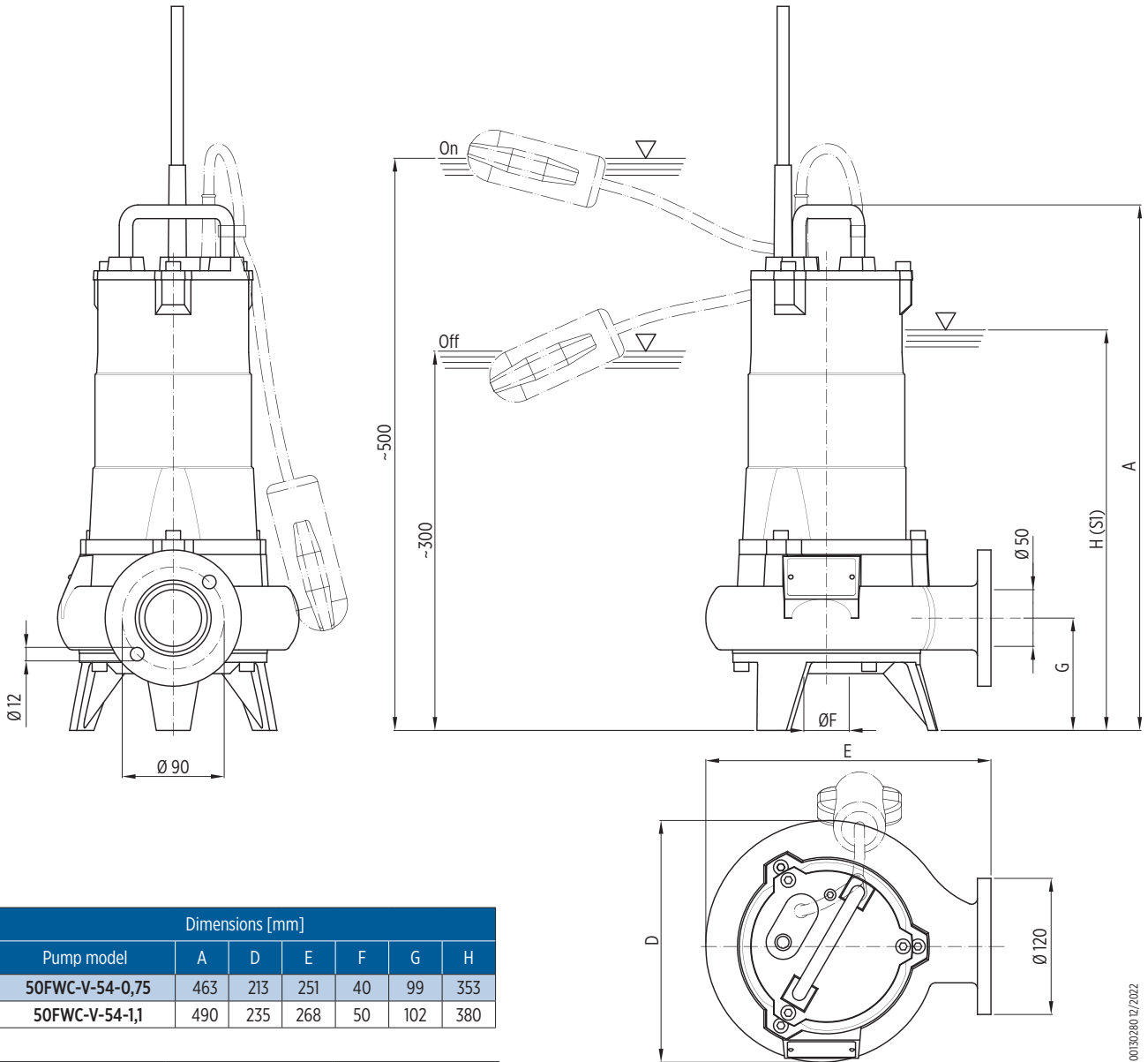

Dimensions [mm]						
Pump model	A	D	E	F	G	H
50FWC-V-54-0,75	463	213	251	40	99	353
50FWC-V-54-1,1	490	235	268	50	102	380

Packaging		
Pump model	Dimensions [mm]	Weight [kg]
50FWC-V-54-0,75	290x245x585	30
50FWC-V-54-1,1	300x260x585	34

00130280.12/2022

TECHNICAL DATA

Pump model	Motor absorbed power P ₁	Rated power P ₂		Voltage	Rated current	Phase	Power cable		Float switch	Running capacitor	Delivery port	Weight [kg]
	[kW]	[kW]	[HP]	[V]	[A]		Length [m]	Type		[μF]		
50FWC-V-54-0,75M	1,2	0,75	1	230	5	1 ~	10	4G1,5	-	14	G2 (Ø50)	29
50FWC-V-54-0,75M-G	1,2	0,75	1	230	5	1 ~	10	4G1,5	•	14	G2 (Ø50)	29
50FWC-V-54-0,75T	1,2	0,75	1	400	1,9	3 ~	10	4G1,5	-	-	G2 (Ø50)	29
50FWC-V-54-0,75T-G	1,2	0,75	1	400	1,9	3 ~	10	4G1,5	•	-	G2 (Ø50)	29
50FWC-V-54-1,1M	1,5	1,1	1,5	230	7,7	1 ~	10	4G1,5	-	20	G2 (Ø50)	33
50FWC-V-54-1,1M-G	1,5	1,1	1,5	230	7,7	1 ~	10	4G1,5	•	20	G2 (Ø50)	33
50FWC-V-54-1,1T	1,5	1,1	1,5	400	2,8	3 ~	10	4G1,5	-	-	G2 (Ø50)	33
50FWC-V-54-1,1T-G	1,5	1,1	1,5	400	2,8	3 ~	10	4G1,5	•	-	G2 (Ø50)	33

"-" = not available

• = available

HYDRAULIC PERFORMANCE AT 50 HZ

Pump model	Phase	Q = Delivery											
		l/sec 0	1	2	3	4	5	6	7	8	9	10	11
		m ³ /h 0	3,6	7,2	10,8	14,4	18	21,6	25,2	28,8	32,4	36	39,6
		US gpm 0	15,8	31,7	47,5	63,4	79,2	92,1	110,9	126,8	142,6	158,5	174,3
		H = Total meters head of water column [m]											
50FWC-V-54-0,75	1 ~	6,4	6,2	5,8	5,3	4,6	3,8	2,8	1,8				
	3 ~	6,4	6,2	5,8	5,3	4,6	3,8	2,8	1,8				
50FWC-V-54-1,1	1 ~	7,4	7	6,6	6,2	5,8	5,4	4,9	4,4	3,9	3,3	2,5	1,6
	3 ~	7,4	7	6,6	6,2	5,8	5,4	4,9	4,4	3,9	3,3	2,5	1,6

HYDRAULIC PERFORMANCE AT 50 HZ

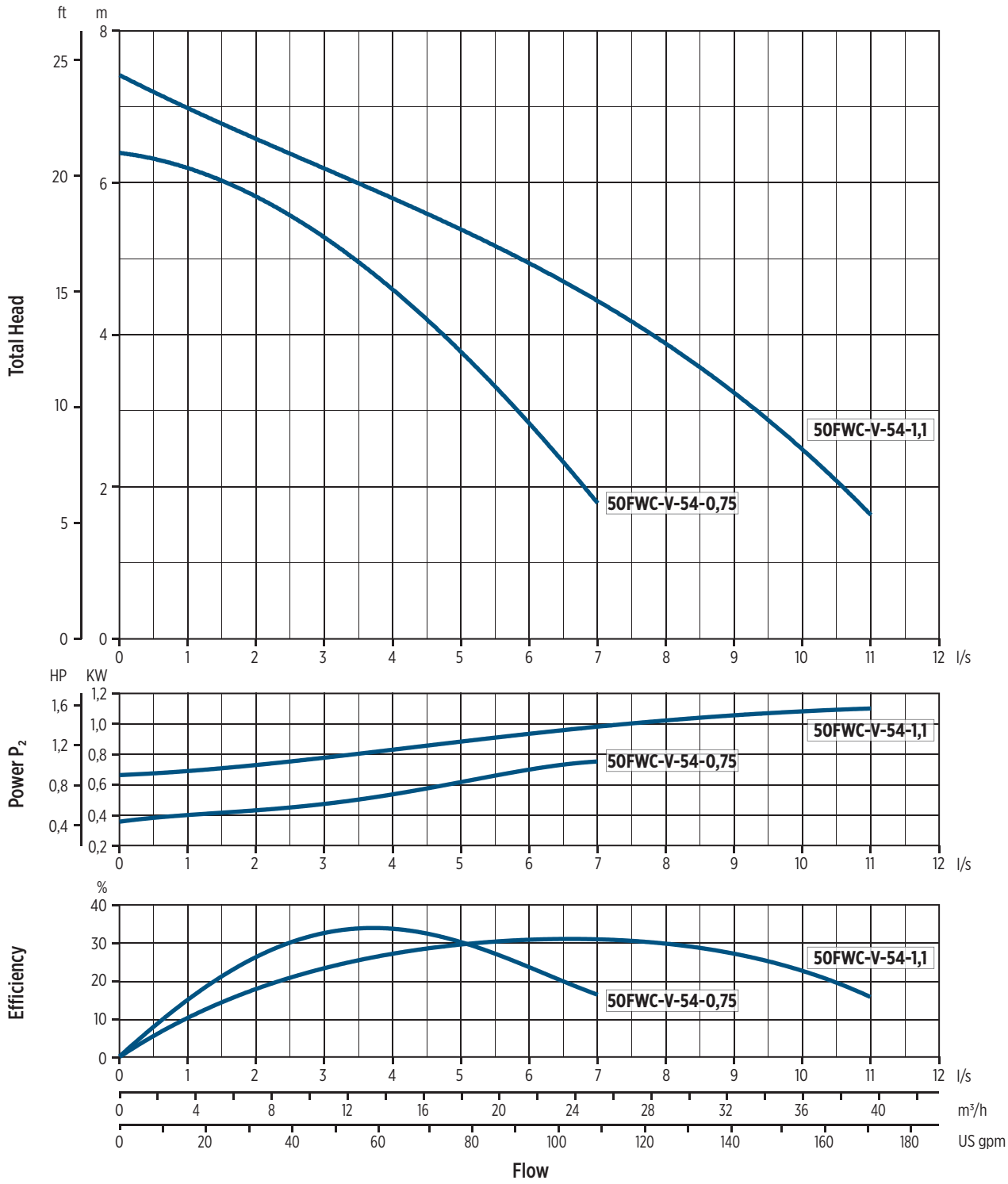

0070096 05/2023

INSTALLATION

INSTALLATION INSTRUCTIONS

PERMANENT INSTALLATION WITH COUPLING SYSTEM

It is the recommended installation for the permanent pumping station. The electric pump is guided by two pipes and it is connected automatically to the coupling system. The quick connection ensures that the pump can be easily removed and re-installed.

TRANSPORTABLE INSTALLATION

Transportable as emergency pump with connection to the hose and for free installation in the well.

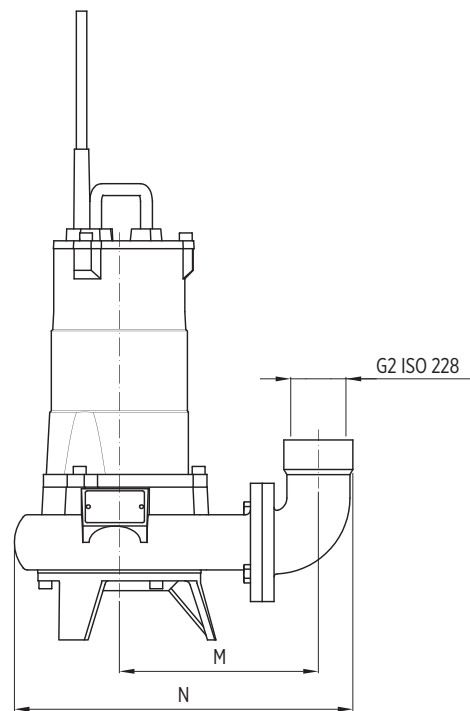
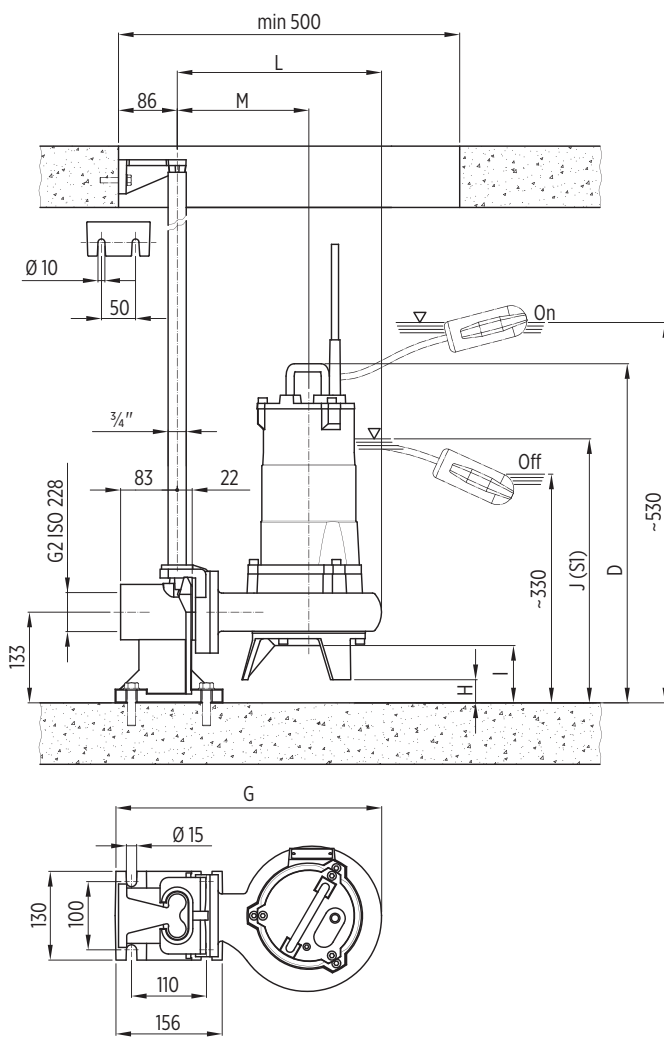

001302860 12/2022

Installation Dimensions [mm]

Pump model	D	G	H	I	J	K	L	M	N
50FWC-V-54-0,75	497	390	34	84	387	193	300	202	344
50FWC-V-54-1,1	521	407	31	81	414	200	316	209	360

65FWC V SERIES 50 HZ

FEATURES & BENEFITS

APPLICATIONS



Domestic / industrial grey water



Extraction of water from ponds, streams or pits and for rainwater collection



Wastewater



MARKETS



RESIDENTIAL



COMMERCIAL

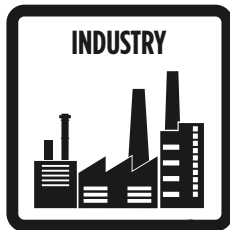

INDUSTRY



AGRICULTURE

CAST IRON SUBMERSIBLE WASTEWATER LIFT PUMPS

Submersible electric pumps particularly suitable for pumping industrial sewage, screened waste water and mud in the pumping stations. They can be used also to lift clear and dirty water and rain water.

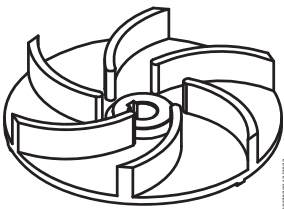

VORTEX IMPELLER

GENERAL FEATURES

		Materials/Constr.design
Vortex impeller		Cast iron EN GJL200
External casing		Cast iron EN GJL200
Pump body		Cast iron EN GJL200
Cover		Cast iron EN GJL200
Mechanical seal	motor side	Seal ring
	pump side	Silicon carbide (SiC/SiC)
Motor shaft		Stainless steel AISI420
Power cable		10 m H07RN-F type, 4G1,5mm ²
		Motor
Constr.design		asynchronous squirrel cage-type oil filled
Type		2 poles; 50 Hz
Insulation class		F
Protection degree		IP68
Voltage	Three-phase	230V ±10%, 400V ±10%
		Limits of use
Maximum liquid temperature		+40 °C
pH of pumped liquid		6 - 10
Liquid density		1,0 kg/dm ³
Maximum immersion depth:		5 m
Min. immersion depth for continuous service		464 mm
Free passage		65 mm
Max. number of starting/hour		20
		Construction options

- 60 Hz version
- Different voltages
- Food-grade white oil

DIMENSIONAL DRAWINGS

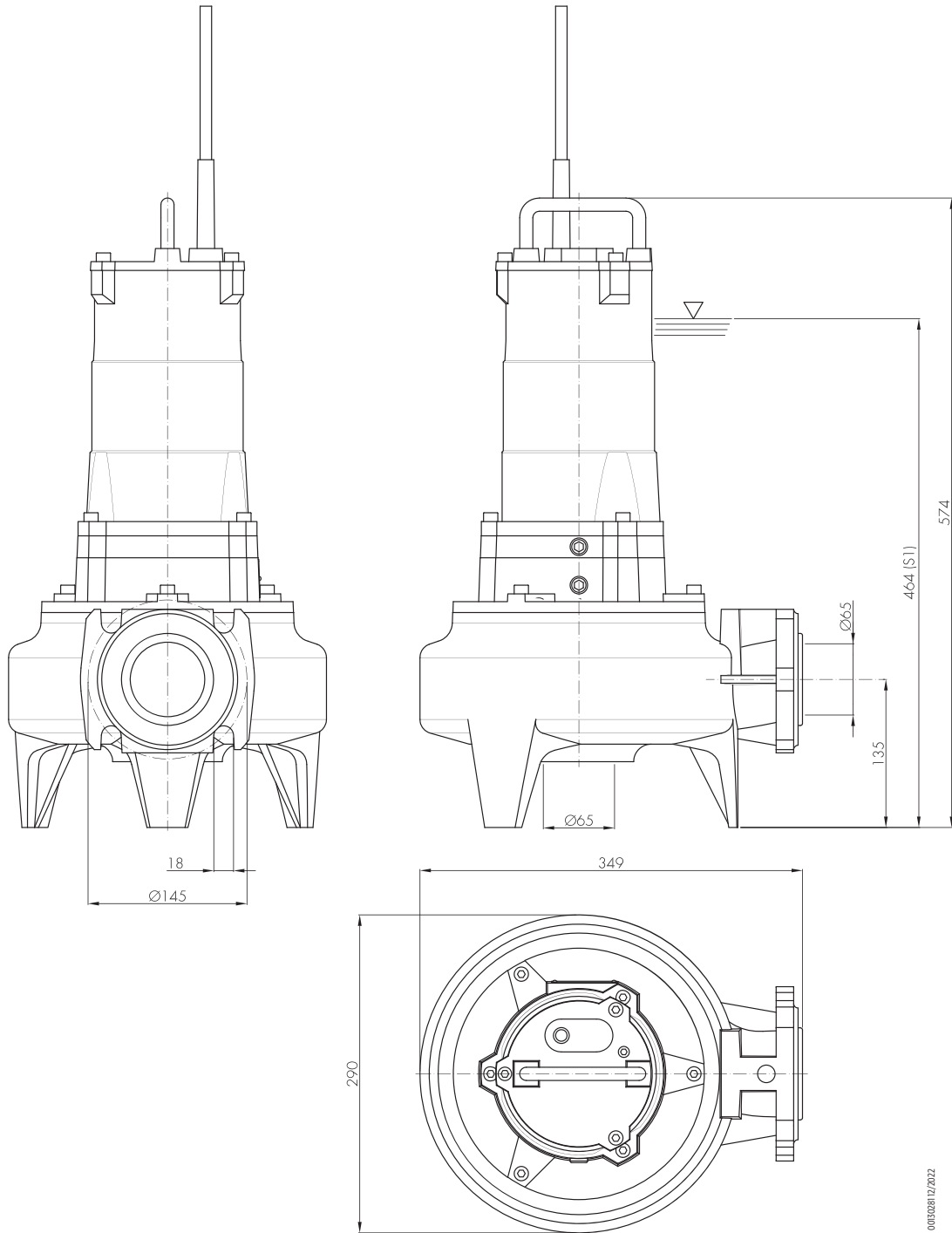

005028112/2022

Packaging		
Pump model	Dimensions [mm]	Weight [kg]
65FWC-V-52-2,2	420x325x675	50

TECHNICAL DATA

Pump model	Motor absorbed power P ₁	Rated power P ₂		Voltage	Rated current	Phase	Power cable		Float switch	Running capacitor	Delivery port	Weight [kg]
	[kW]	[kW]	[HP]	[V]	[A]		Length [m]	Type		[μF]		
65FWC-V-52-2,2T	3,2	2,2	3	400	5,2	3 -	10	4G1,5	-	-	DN65	48

“-” = not available

• = available

HYDRAULIC PERFORMANCE AT 50 HZ

Pump model	Phase	Q = Delivery										
		l/sec 0	4	6	8	9	10	11	12	13	14	15
		m ³ /h 0	14,4	21,6	28,8	32,4	36	39,6	43,2	46,8	50,4	54
		US gpm 0	63,4	92,1	126,8	142,6	158,5	174,3	190,2	206	221,9	237,7
		H = Total meters head of water column [m]										
65FWC-V-52-2,2	3 -	16,5	12,5	10,2	9	8	6,8	6	5,3	3,7	2	1,5

HYDRAULIC PERFORMANCE AT 50 HZ

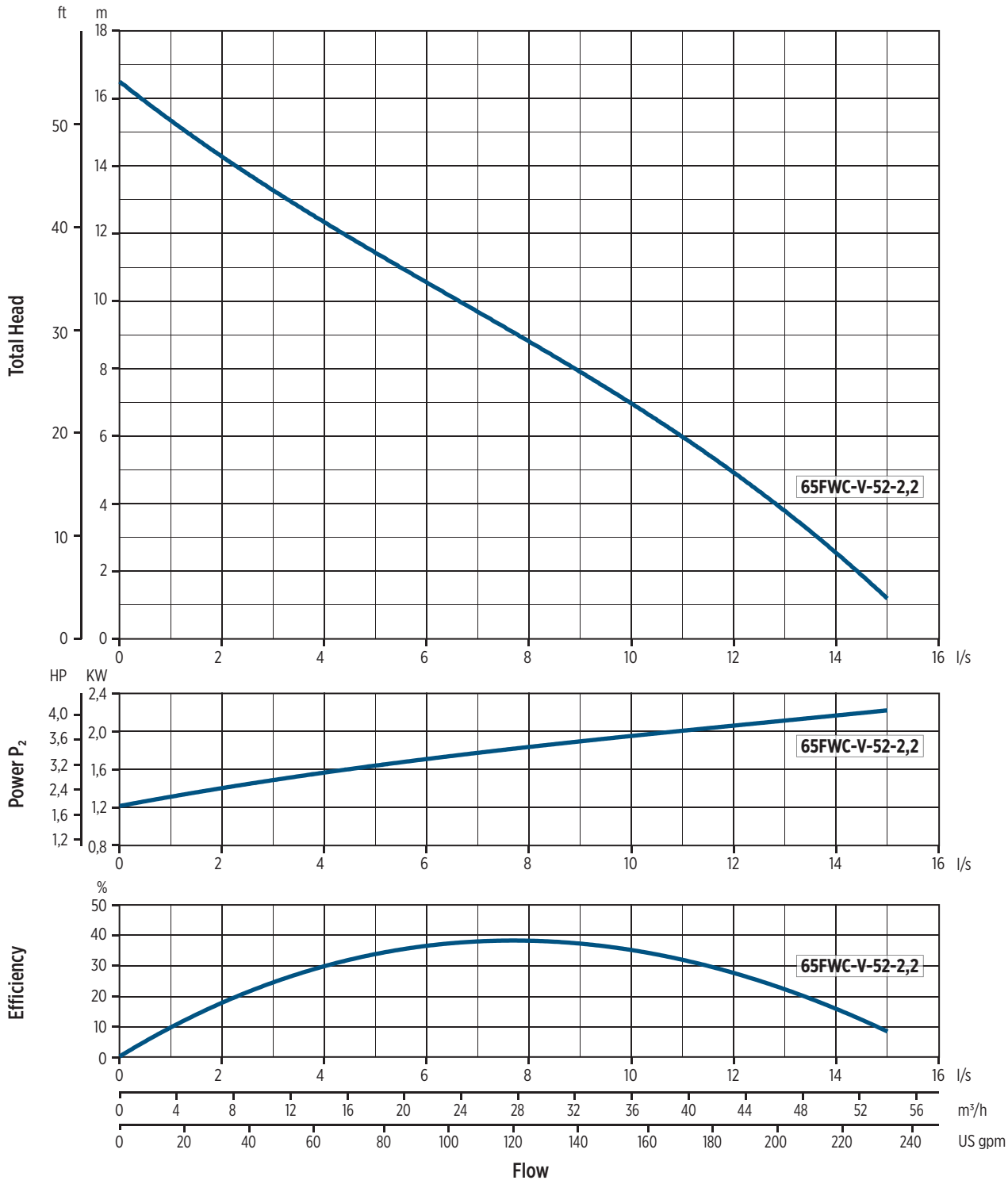

002009712/2022

INSTALLATION

INSTALLATION INSTRUCTIONS

PERMANENT INSTALLATION WITH COUPLING SYSTEM

It is the recommended installation for the permanent pumping station. The electric pump is guided by two pipes and it is connected automatically to the coupling system. The quick connection ensures that the pump can be easily removed and re-installed.

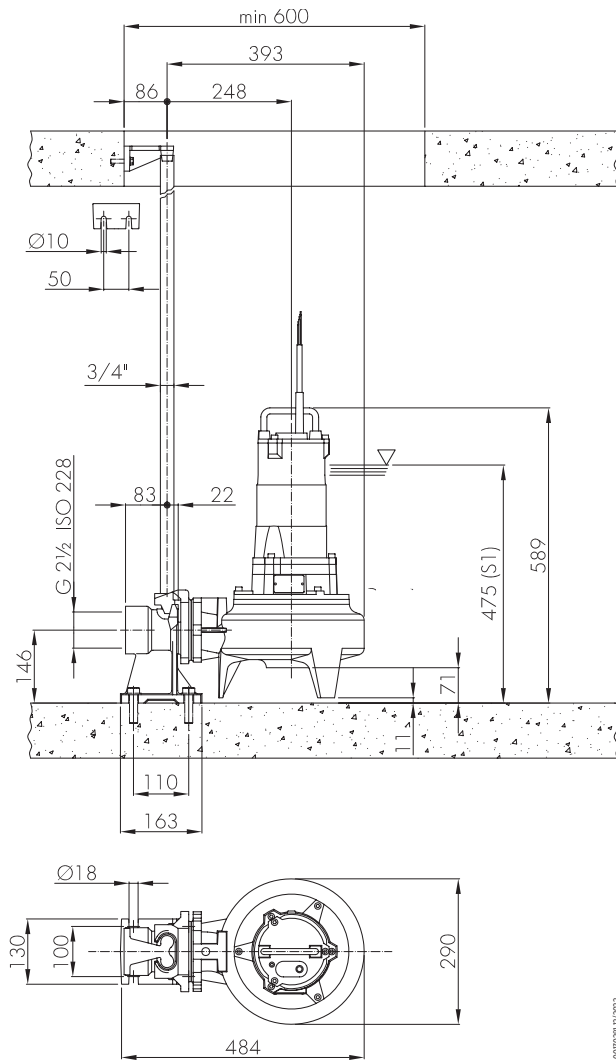

010028 12/2022

TRANSPORTABLE INSTALLATION

Transportable as emergency pump with connection to the hose and for free installation in the well.

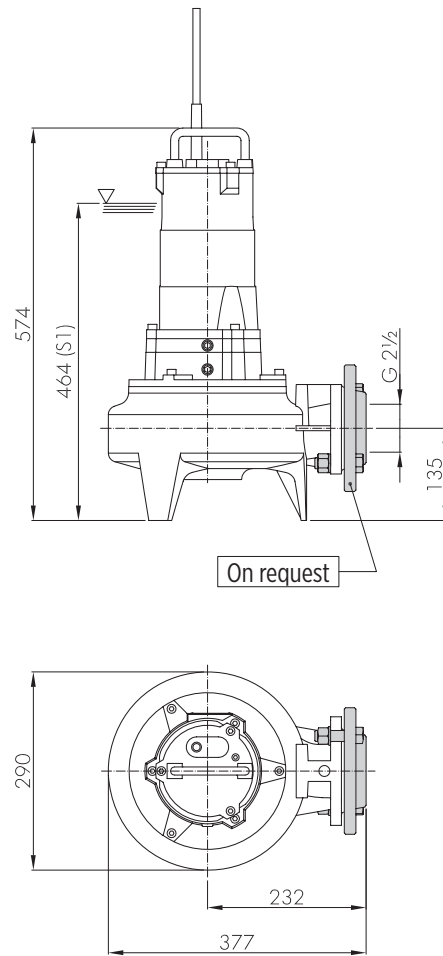

010028 12/2022

65FWC M SERIES 50 HZ

FEATURES & BENEFITS

APPLICATIONS



Domestic / industrial grey water



Extraction of water from ponds, streams or pits and for rainwater collection



Wastewater



MARKETS



RESIDENTIAL



COMMERCIAL



INDUSTRY



AGRICULTURE

CAST IRON SUBMERSIBLE WASTEWATER LIFT PUMPS

Submersible electric pumps suitable for pumping screened waste water, draining the sewage of blocks of flats and houses and flooded premises in general.

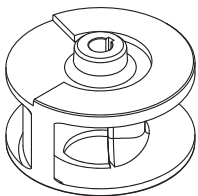

©2018/19/2021

SINGLE-CHANNEL IMPELLER

GENERAL FEATURES

		Materials/Constr.design
Single-channel impeller		Cast iron EN GJL200
External casing		Cast iron EN GJL200
Pump body		Cast iron EN GJL200
Cover		Cast iron EN GJL200
Mechanical seal	motor side	Seal ring
	pump side	Silicon carbide (SiC/SiC)
Motor shaft		Stainless steel AISI420
Power cable		10 m H07RN-F type, 4G1,5mm ²
Motor		
Constr.design		asynchronous squirrel cage-type oil filled
Type		2 poles; 50 Hz
Insulation class		F
Protection degree		IP68
Voltage	Three-phase	230V ±10%, 400V ±10%
Limits of use		
Maximum liquid temperature		6 - 10
pH of pumped liquid		1,0 kg/dm ³
Liquid density		5 m
Maximum immersion depth:		445 mm
Min. immersion depth for continuous service		50 mm
Free passage		20
Max. number of starting/hour		20
Construction options		

- 60 Hz version
- Different voltages
- Food-grade white oil

DIMENSIONAL DRAWINGS

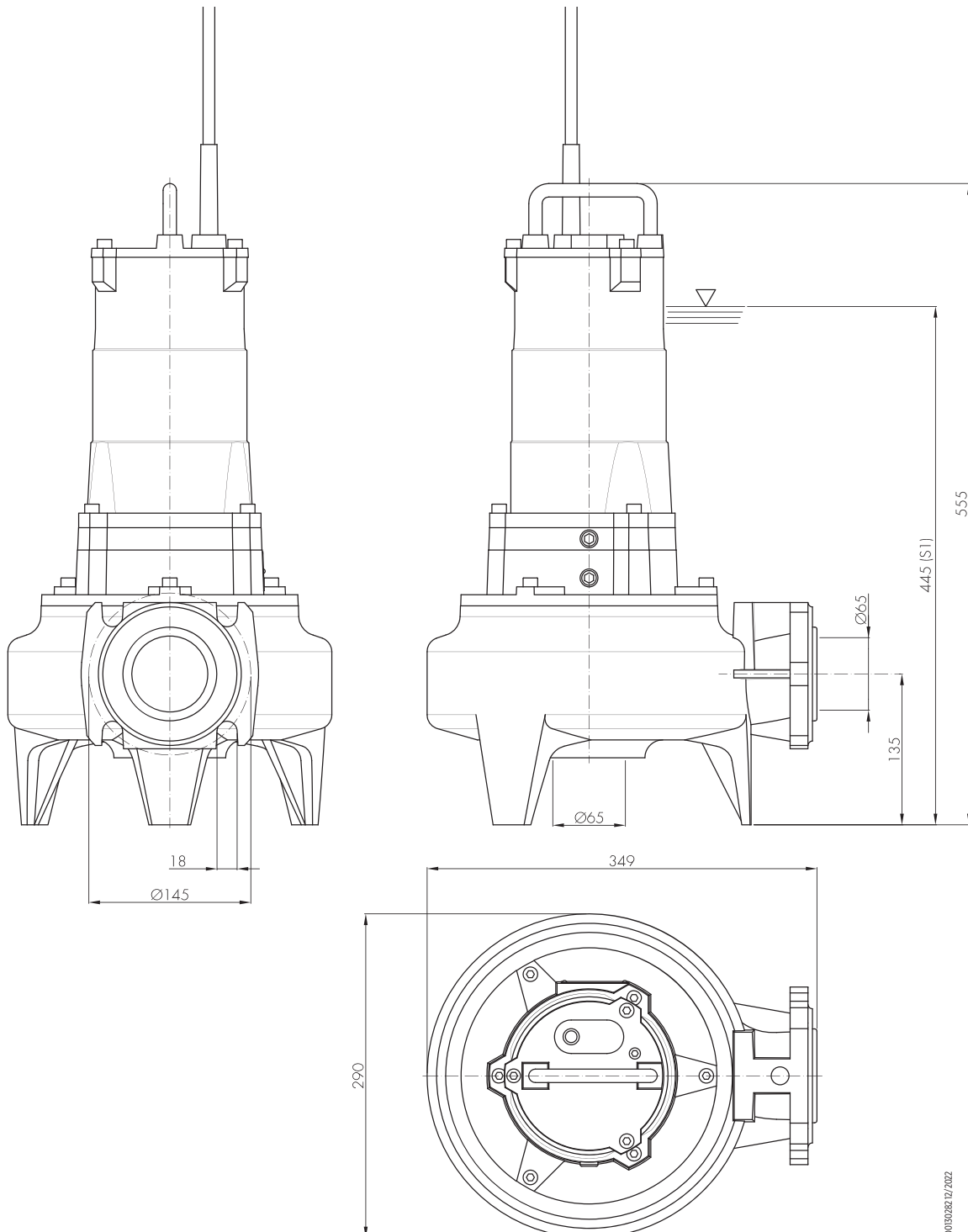

00130282.12/2022

Packaging		
Pump model	Dimensions [mm]	Weight [kg]
65FWC-M-52-1,6T	420x325x675	52
65FWC-M-52-2,2T	420x325x675	52

TECHNICAL DATA

Pump model	Motor absorbed power P ₁	Rated power P ₂		Voltage	Rated current	Phase	Power cable		Float switch	Running capacitor	Delivery port	Weight [kg]
	[kW]	[kW]	[HP]	[V]	[A]		Length [m]	Type		[μF]		
65FWC-M-52-1,6T	2,5	1,6	2,1	400	4,4	3 -	10	4G1,5	-	-	DN65	50
65FWC-M-52-2,2T	3,2	2,2	3	400	5,2	3 -	10	4G1,5	-	-	DN65	50

“-” = not available
 • = available

HYDRAULIC PERFORMANCE AT 50 HZ

Pump model	Phase	Q = Delivery												
		l/sec 0	4	6	8	9	10	11	12	13	14	15	16	18
		m ³ /h 0	14,4	21,6	28,8	32,4	36	39,6	43,2	46,8	50,4	54	57,6	64,8
		US gpm 0	63,4	92,1	126,8	142,6	158,5	174,3	190,2	206	221,9	237,7	253,6	285,3
		H = Total meters head of water column [m]												
65FWC-M-52-1,6	3 -	18,5	12,5	10,4	8,5	7,7	6,8	5,7	4,9	3,6	2,3	1		
65FWC-M-52-2,2	3 -	24	17,8	15,3	13,2	12	11,3	10,2	9,1	7,9	6,6	5,1	3,6	1

HYDRAULIC PERFORMANCE AT 50 HZ

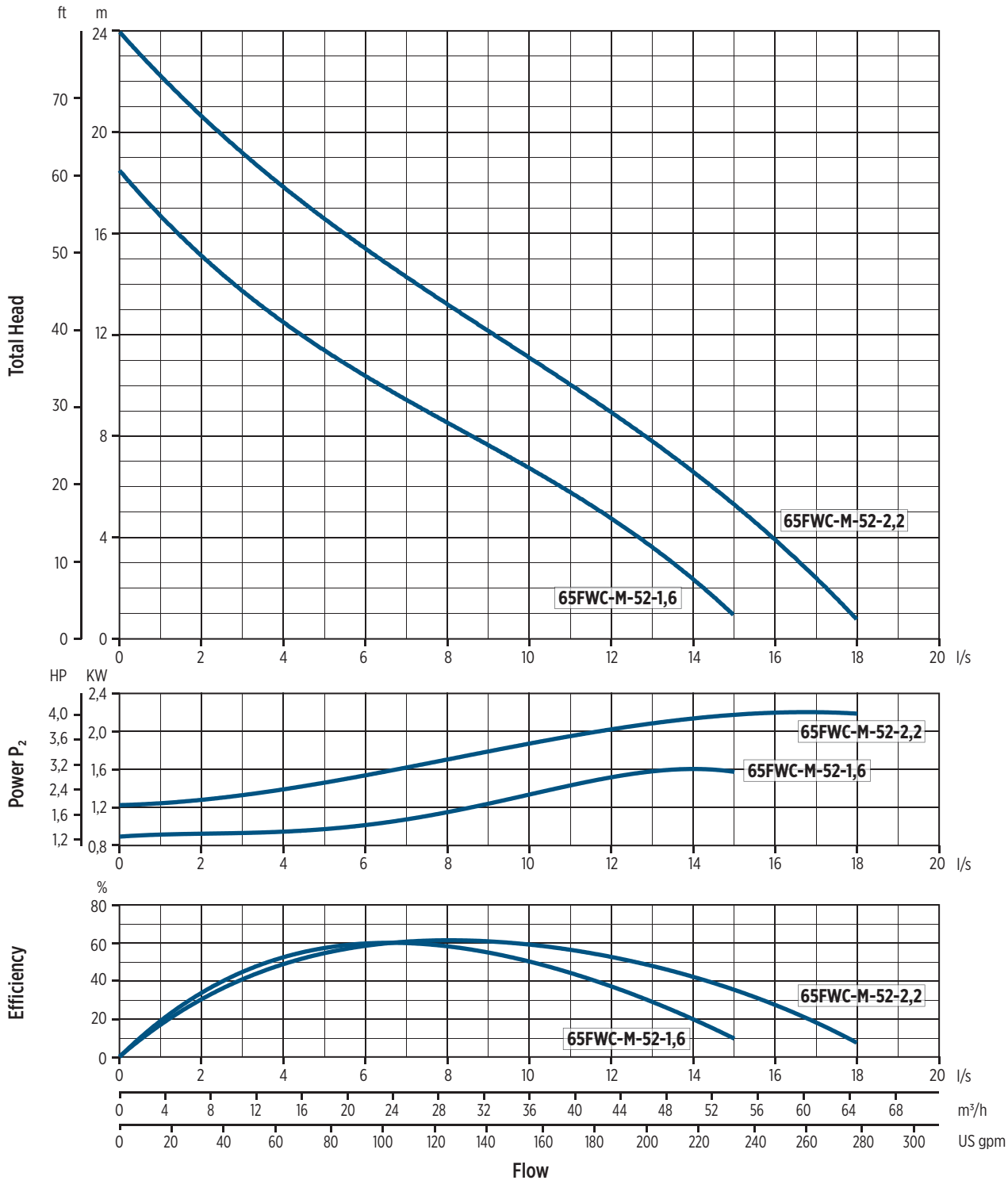

0010098 12/2022

INSTALLATION

INSTALLATION INSTRUCTIONS

PERMANENT INSTALLATION WITH COUPLING SYSTEM

It is the recommended installation for the permanent pumping station. The electric pump is guided by two pipes and it is connected automatically to the coupling system. The quick connection ensures that the pump can be easily removed and re-installed.

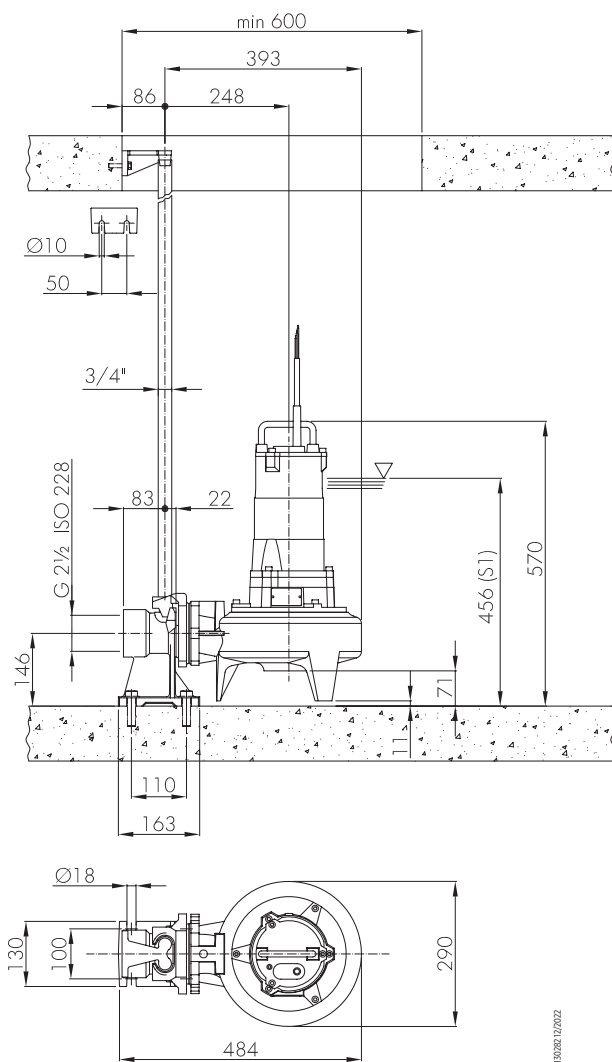

00102062.12/2022

TRANSPORTABLE INSTALLATION

Transportable as emergency pump with connection to the hose and for free installation in the well.

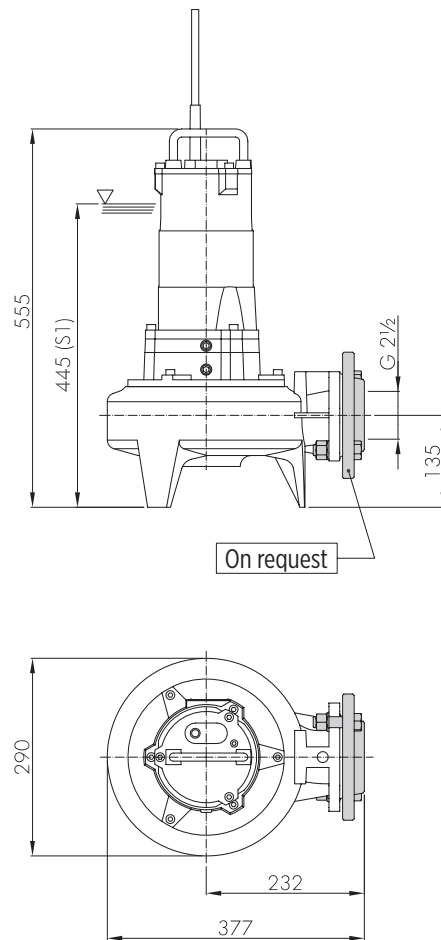

00102062.12/2022

65FWC V4 SERIES 50 HZ

FEATURES & BENEFITS

APPLICATIONS



Domestic / industrial grey water



Extraction of water from ponds, streams or pits and for rainwater collection



Wastewater



MARKETS



RESIDENTIAL



COMMERCIAL



INDUSTRY



AGRICULTURE

CAST IRON SUBMERSIBLE WASTEWATER LIFT PUMPS

Submersible electric pumps particularly suitable for pumping industrial sewage, screened waste water and mud in the pumping stations. They can be used also to lift clear and dirty water and rain water.

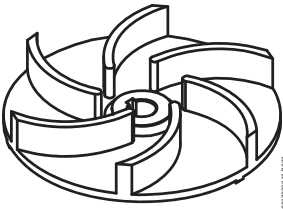

VORTEX IMPELLER

GENERAL FEATURES

		Materials/Constr.design
Vortex impeller		Cast iron EN GJL200
Pump body		Cast iron EN GJL200
External casing		Cast iron EN GJL200
Cover		Cast iron EN GJL200
Mechanical seal		Silicon carbide (SiC/SiC)
Motor shaft		Stainless steel AISI420
Power cable	Type	10 m H07RN-F type
	Single-phase	4G1,5mm ² , capacitor box and SCHUKO plug (CEE 7/VII)
	Three-phase	4G1,5mm ²
		Motor
Constr.design		asynchronous squirrel cage-type oil filled
Type		4 poles; 50 Hz
Insulation class		F
Protection degree		IP68
Voltage	Single-phase	230V ±6% built-in overheating protection capacitor box and SCHUKO plug (CEE 7/VII)
	Three-phase	230V ±10%, 400V ±10%
		Limits of use
Maximum liquid temperature		+40 °C
pH of pumped liquid		6 - 10
Liquid density		1,0 kg/dm ³
Maximum immersion depth:		5 m
Min. immersion depth for continuous service		442 mm
Free passage		60 mm
Max. number of starting/hour		20
		Construction options

- 60 Hz version
- Different voltages
- Food-grade white oil

DIMENSIONAL DRAWINGS

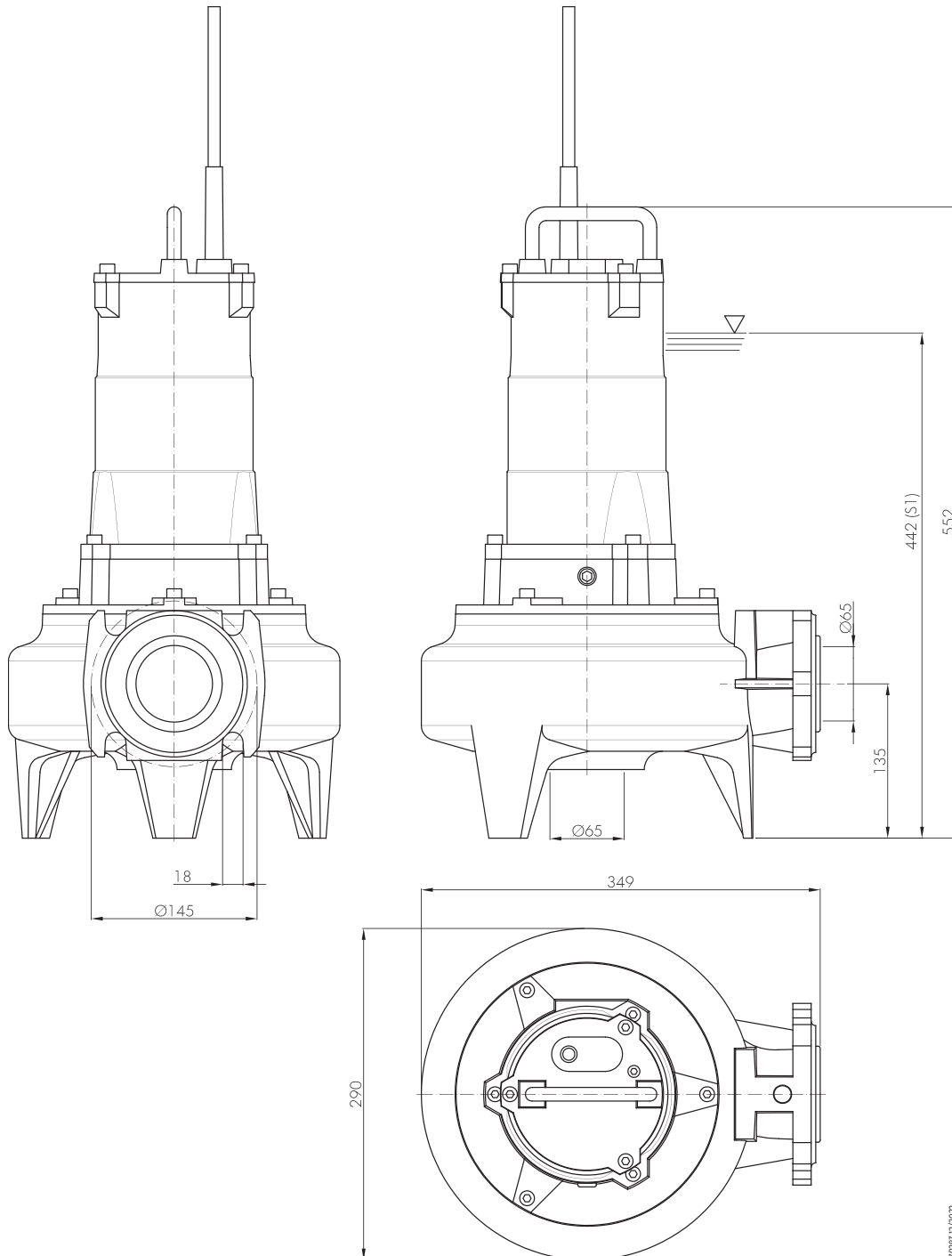

00130283 12/24/22

Packaging		
Pump model	Dimensions [mm]	Weight [kg]
65FWC-V-54-0,75	420x325x675	40
65FWC-V-54-1,1	420x325x675	41
65FWC-V-54-1,6	420x325x675	42

TECHNICAL DATA

Pump model	Motor absorbed power P ₁	Rated power P ₂		Voltage	Rated current	Phase	Power cable		Float switch	Running capacitor	Delivery port	Weight [kg]
	[kW]	[kW]	[HP]	[V]	[A]		Length [m]	Type		[μF]		
65FWC-V-54-0,75M	1	0,75	1	230	5	1 -	10	4G1,5	-	14	DN65	38
65FWC-V-54-0,75M-G	1	0,75	1	230	5	1 -	10	4G1,5	•	14	DN65	38
65FWC-V-54-0,75T	1	0,75	1	400	1,9	3 -	10	4G1,5	-	-	DN65	38
65FWC-V-54-0,75T-G	1	0,75	1	400	1,9	3 -	10	4G1,5	•	-	DN65	38
65FWC-V-54-1,1M	1,5	1,1	1,5	230	7	1 -	10	4G1,5	-	20	DN65	39
65FWC-V-54-1,1M-G	1,5	1,1	1,5	230	7	1 -	10	4G1,5	•	20	DN65	39
65FWC-V-54-1,1T	1,5	1,1	1,5	400	2,8	3 -	10	4G1,5	-	-	DN65	39
65FWC-V-54-1,1T-G	1,5	1,1	1,5	400	2,8	3 -	10	4G1,5	•	-	DN65	39
65FWC-V-54-1,6T	2,5	1,6	2,1	400	4,4	3 -	10	4G1,5	-	-	DN65	40

"-" = not available

• = available

HYDRAULIC PERFORMANCE AT 50 HZ

Pump model	Phase	Q = Delivery										
		l/sec 0	4	6	8	9	10	11	12	13	14	15
		m ³ /h 0	14,4	21,6	28,8	32,4	36	39,6	43,2	46,8	50,4	54
		US gpm 0	63,4	92,1	126,8	142,6	158,5	174,3	190,2	206	221,9	237,7
H = Total meters head of water column [m]												
65FWC-V-54-0,75	1 -	6	4,7	3,8	3	2						
	3 -	6	4,7	3,8	3	2						
65FWC-V-54-1,1	1 -	8,2	7	6,1	5	4,3	3,7	3	2,2	1,2		
	3 -	8,2	7	6,1	5	4,3	3,7	3	2,2	1,2		
65FWC-V-54-1,6	3 -	11	9,5	8,5	7,2	6,6	6,1	5,9	5,4	4,9	4	2,8

HYDRAULIC PERFORMANCE AT 50 HZ

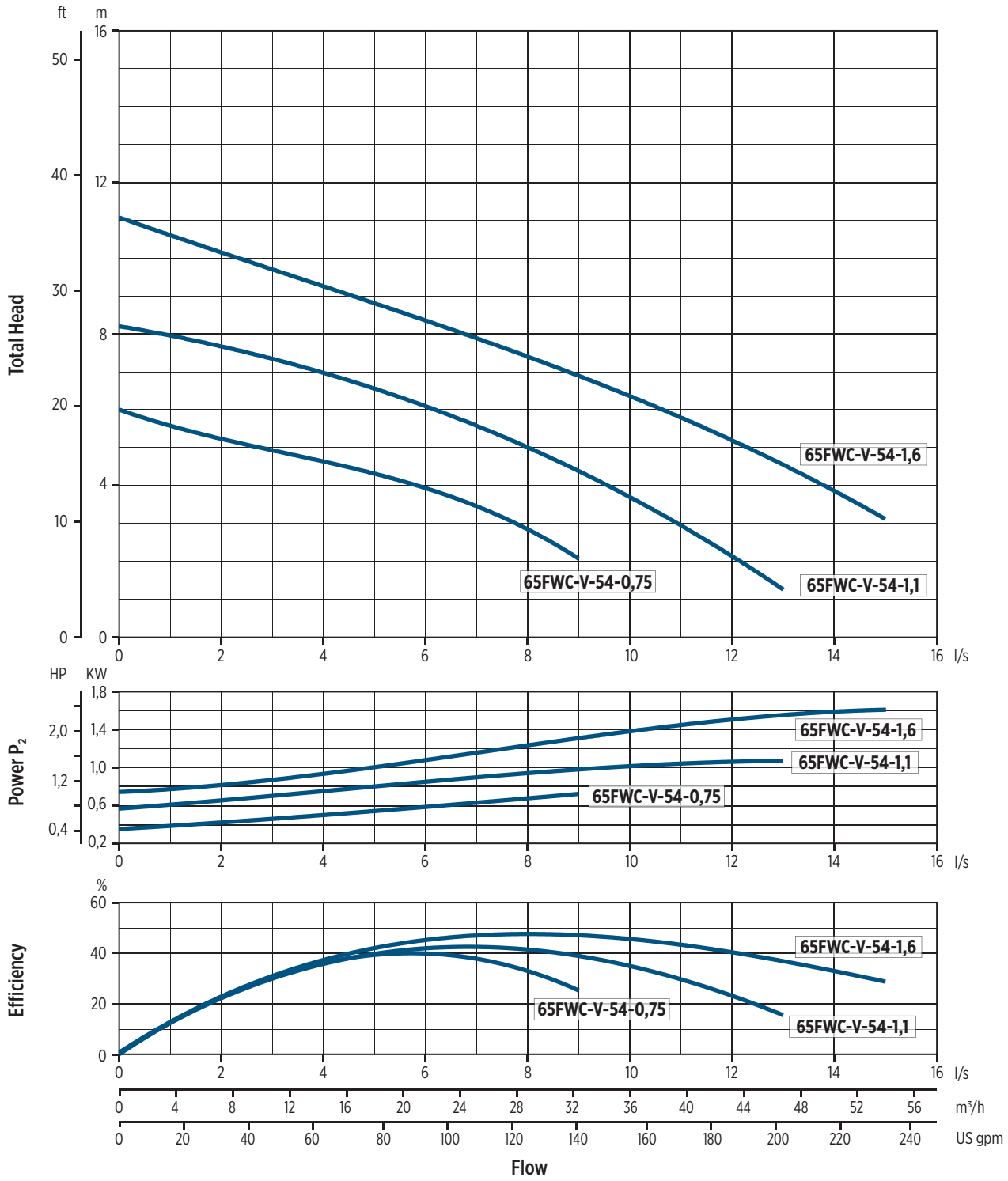

0020099.12/2022

INSTALLATION

INSTALLATION INSTRUCTIONS

PERMANENT INSTALLATION WITH COUPLING SYSTEM

It is the recommended installation for the permanent pumping station. The electric pump is guided by two pipes and it is connected automatically to the coupling system. The quick connection ensures that the pump can be easily removed and re-installed.

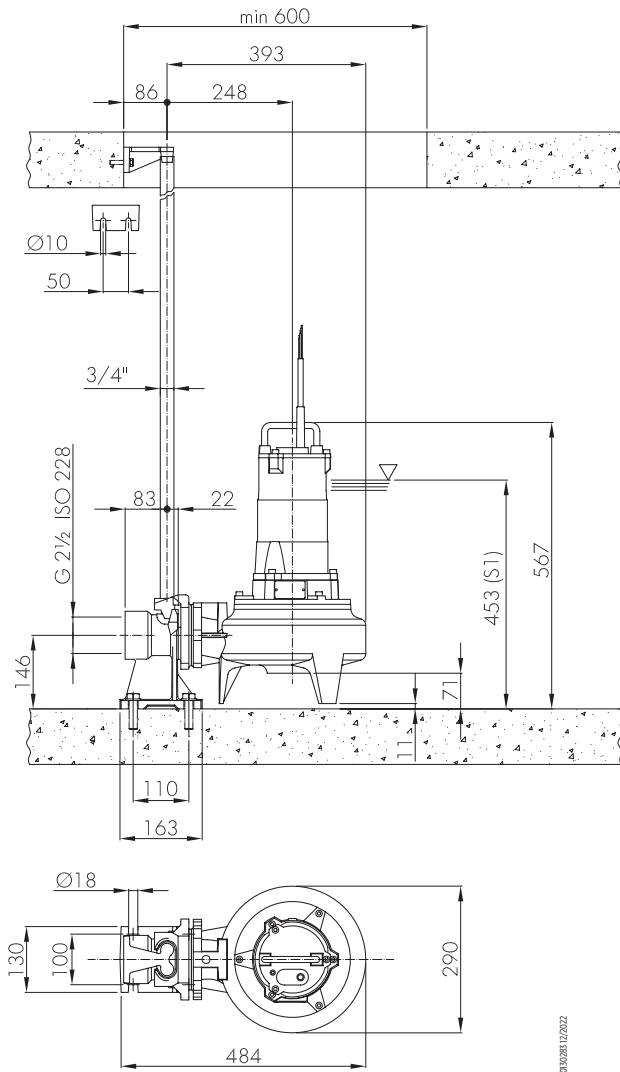

00130285 12/2022

TRANSPORTABLE INSTALLATION

Transportable as emergency pump with connection to the hose and for free installation in the well.

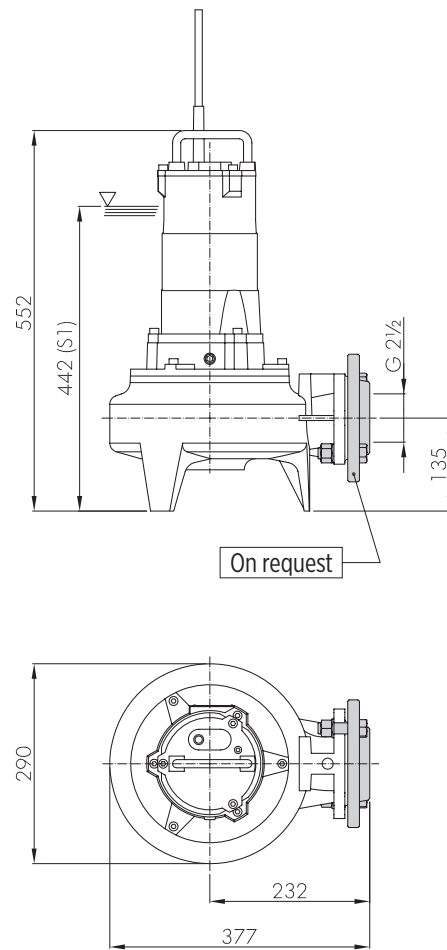

00130285 12/2022

80FWC M4 SERIES 50 HZ

FEATURES & BENEFITS

APPLICATIONS



Domestic / industrial grey water



Extraction of water from ponds, streams or pits and for rainwater collection



Wastewater



MARKETS

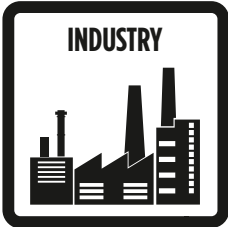

CAST IRON SUBMERSIBLE WASTEWATER LIFT PUMPS

Submersible electric pumps particularly suitable for pumping industrial sewage, screened waste water and mud in the pumping stations. They can be used also to lift clear and dirty water and rain water.

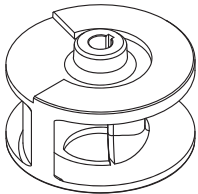

00008710/2022

SINGLE-CHANNEL IMPELLER

GENERAL FEATURES

		Materials/Constr.design
Single-channel impeller		Cast iron EN GJS400
External casing		Cast iron EN GJL250
Pump body		Cast iron EN GJL250
Cover		Cast iron EN GJL250
Mechanical seal	Mechanical seal	Graphite/Alumina
	pump side	Silicon carbide (SiC/SiC)
Motor shaft		Stainless steel AISI420
Power cable	Type	10 m SIRN8-F type
	80FWC-M-54-2,2T, 80FWC-M-54-3,1T	4G1,5+3x1mm ²
	80FWC-M-54-5,5T	4G2,5+3x1mm ²
		Motor
Constr.design		asynchronous squirrel cage-type in dry chamber
Type		4 poles; 50 Hz
Insulation class		F
Protection degree		IP68
Voltage	Three-phase	400V ±10%
Probe		Thermal in the winding
		Conductivity in the oil chamber
		Limits of use
Maximum liquid temperature		+40 °C
pH of pumped liquid		6 - 10
Liquid density		1,0 kg/dm ³
Maximum immersion depth:		5 m
Min. immersion depth for continuous service		517 mm
Free passage		80 mm
Max. number of starting/hour		20
		Construction options

- 60 Hz version
- Different voltages

DIMENSIONAL DRAWINGS

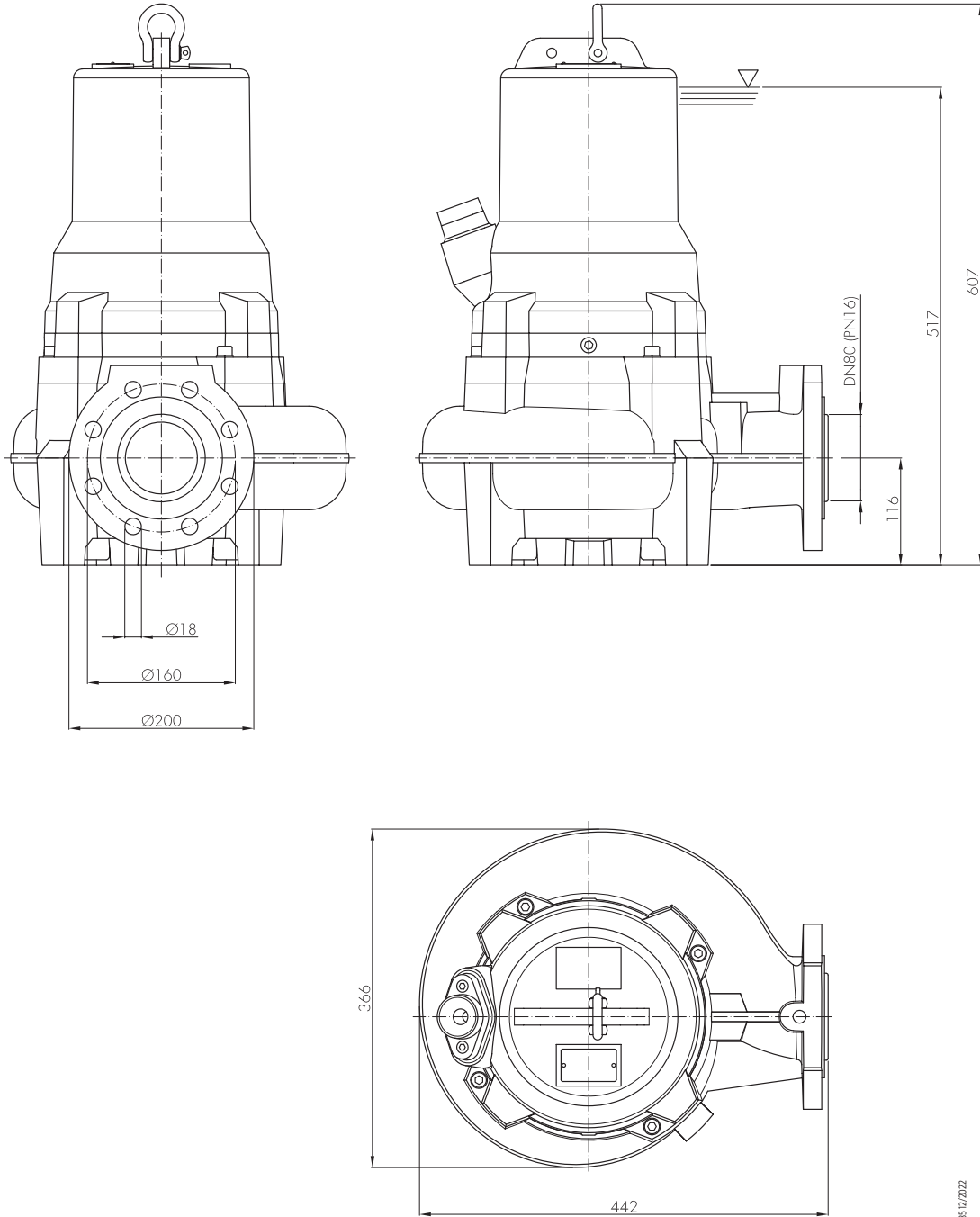

00180285 11/2012

Packaging		
Pump model	Dimensions [mm]	Weight [kg]
80FWC-M-54-2,2T	475x370x985	99
80FWC-M-54-3,1T	475x370x985	102
80FWC-M-54-5,5T	475x370x985	114

TECHNICAL DATA

Pump model	Motor absorbed power P ₁	Rated power P ₂		Voltage	Rated current	Phase	Power cable		Float switch	Delivery port	Weight [kg]
	[kW]	[kW]	[HP]	[V]	[A]		Length [m]	Type			
80FWC-M-54-2,2T	2,8	2,2	3	400	5,4	3 -	10	4G1,5+3x1	-	DN80	96
80FWC-M-54-3,1T	3,9	3,1	4,2	400	7,5	3 -	10	4G1,5+3x1	-	DN80	99
80FWC-M-54-5,5T	6,6	5,5	7,5	400	11,7	3 -	10	4G2,5+3x1	-	DN80	111

"-" = not available

• = available

HYDRAULIC PERFORMANCE AT 50 HZ

Pump model	Phase	Q = Delivery												
		l/sec 0	6	10	15	20	25	30	35	38	40	42,8	45	47
		m ³ /h 0	21,6	36	54	72	90	108	126	136,8	144	154,1	162	169,2
		US gpm 0	92,1	158,5	237,7	317	396,2	475,5	554,8	602,3	634	678,4	713,3	745
		H = Total meters head of water column [m]												
80FWC-M-54-2,2T	3 -	10,8	8,8	7,6	6,4	5,3	3,7	2,4	2					
80FWC-M-54-3,1T	3 -	15,6	12,1	10,8	9,6	8,4	7,1	5,5	5,2	3,7	2			
80FWC-M-54-5,5T	3 -	19,8	16,6	15,1	13,6	12,4	11	9,6	9,2	7,9	6,6	5,2	3	2

HYDRAULIC PERFORMANCE AT 50 HZ

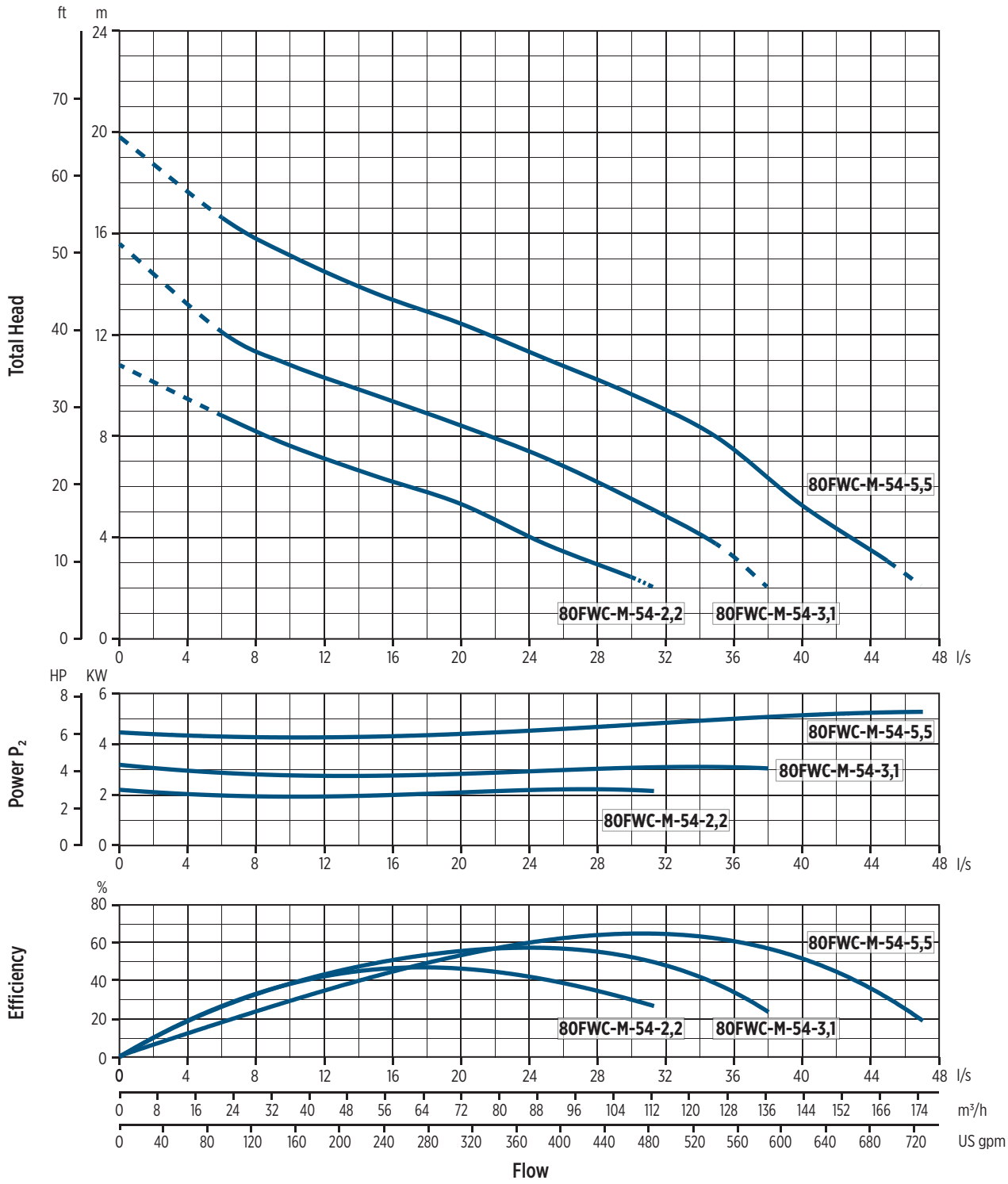

00201012/2022

INSTALLATION

INSTALLATION INSTRUCTIONS

PERMANENT INSTALLATION WITH COUPLING SYSTEM

It is the recommended installation for the permanent pumping station. The electric pump is guided by two pipes and it is connected automatically to the coupling system. The quick connection ensures that the pump can be easily removed and re-installed.

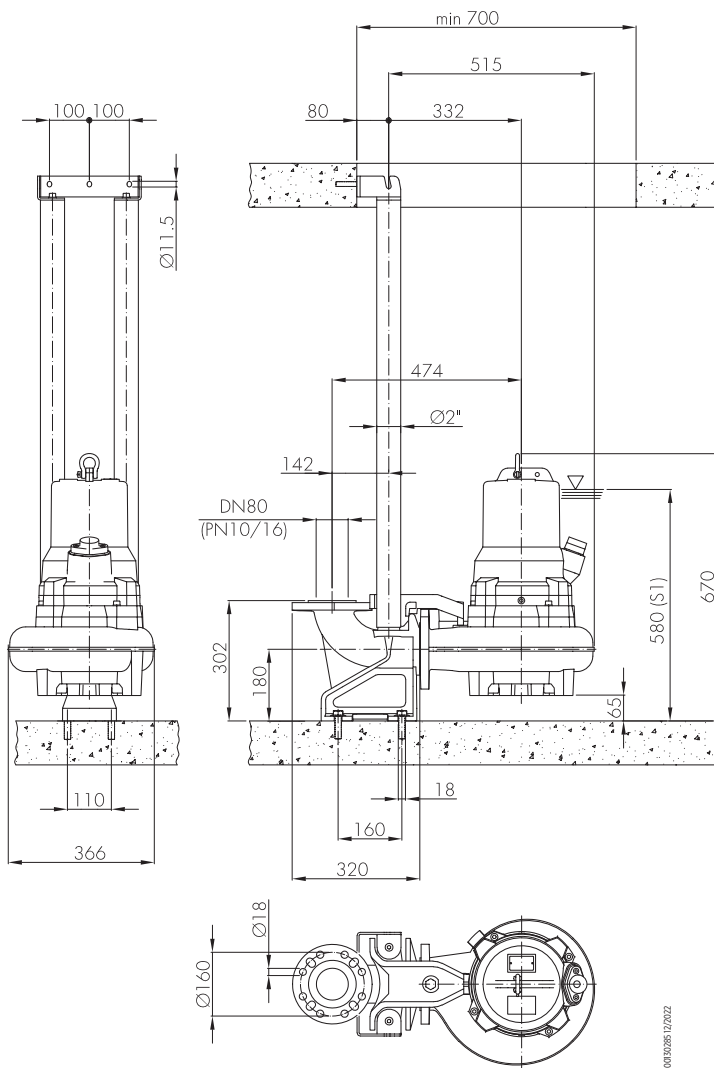

0050265/12/2022

TRANSPORTABLE INSTALLATION

Transportable as emergency pump with connection to the hose and for free installation in the well.

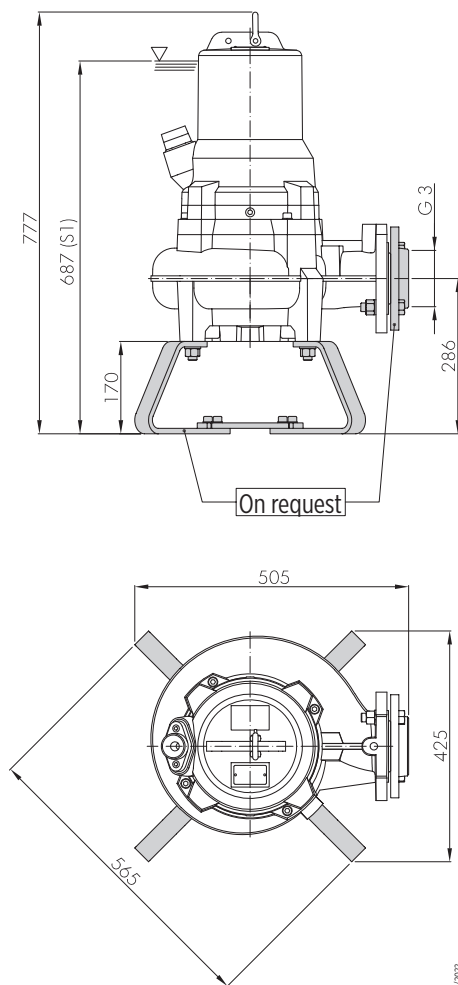

328517/2022

80FWC V4 SERIES 50 HZ

FEATURES & BENEFITS

APPLICATIONS



Domestic / industrial grey water



Extraction of water from ponds, streams or pits and for rainwater collection



Wastewater



For liquids with an high solid content or with filamentous particles



MARKETS



CAST IRON SUBMERSIBLE WASTEWATER LIFT PUMPS

Submersible electric pumps particularly suitable for pumping industrial sewage, screened waste water and mud in the pumping stations. They can be used also to lift clear and dirty water and rain water.

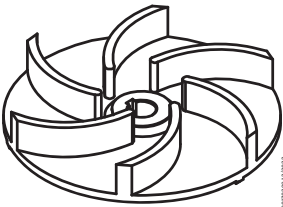

VORTEX IMPELLER

GENERAL FEATURES

Materials/Constr.design	
Vortex impeller	Cast iron EN GJL250
External casing	Cast iron EN GJL250
Pump body	Cast iron EN GJL250
Cover	Cast iron EN GJL250
Mechanical seal	Graphite/Alumina
	pump side Silicon carbide (SiC/SiC)
Motor shaft	Stainless steel AISI420
Power cable	Type 10 m SIRN8-F type
	80FWC-V-54-1,6T, 80FWC-V-54-2,2T, 80FWC-V-54-3,1T 4G1,5+3x1mm ²
	80FWC-V-54-5,5T 4G2,5+3x1mm ²
Motor	
Constr.design	asynchronous squirrel cage-type in dry chamber
Type	4 poles; 50 Hz
Insulation class	F
Protection degree	IP68
Voltage	Three-phase 400V ±10%
Probe	Thermal in the winding
	Conductivity in the oil chamber
Limits of use	
Maximum liquid temperature	+40 °C
pH of pumped liquid	6 - 10
Liquid density	1,0 kg/dm ³
Maximum immersion depth:	5 m
Min. immersion depth for continuous service	500 mm
Free passage	80 mm
Max. number of starting/hour	20
Construction options	

- 60 Hz version
- Different voltages

DIMENSIONAL DRAWINGS

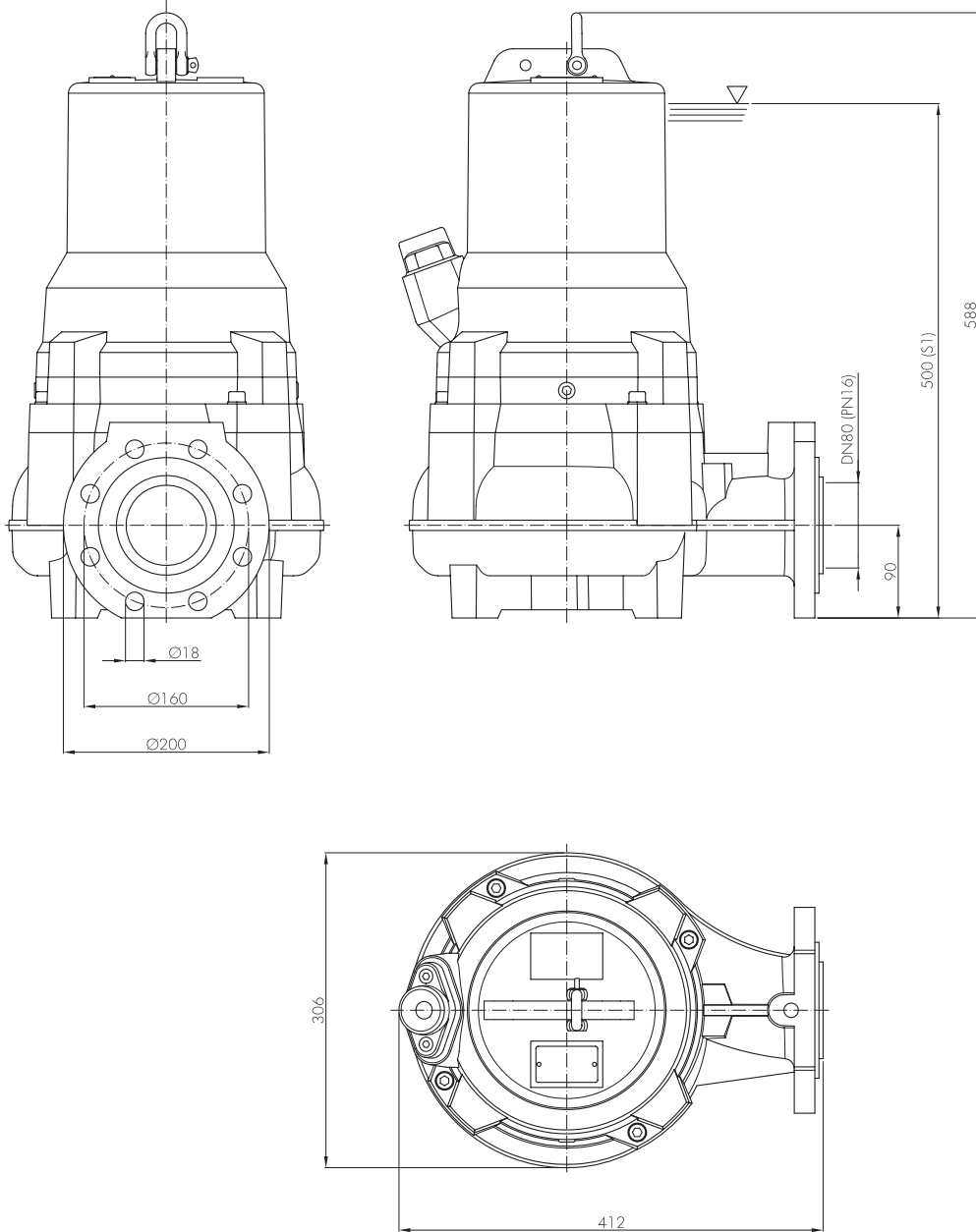

0030284-12/2022

Packaging		
Pump model	Dimensions [mm]	Weight [kg]
80FWC-M-54-2,2T	475x370x985	99
80FWC-M-54-3,1T	475x370x985	102
80FWC-M-54-5,5T	475x370x985	114
80FWC-V-54-1,6T	420x325x675	85
80FWC-V-54-2,2T	420x325x675	87
80FWC-V-54-3,1T	420x325x675	91
80FWC-V-54-5,5T	420x325x675	102

TECHNICAL DATA

Pump model	Motor absorbed power P ₁	Rated power P ₂		Voltage	Rated current	Phase	Power cable		Float switch	Delivery port	Weight [kg]
	[kW]	[kW]	[HP]	[V]	[A]		Length [m]	Type			
80FWC-V-54-1,6T	2,3	1,6	2,1	400	4,1	3 -	10	4G1,5+3x1	-	DN80	83
80FWC-V-54-2,2T	2,8	2,2	3	400	5,4	3 -	10	4G1,5+3x1	-	DN80	85
80FWC-V-54-3,1T	3,9	3,1	4,2	400	7,5	3 -	10	4G1,5+3x1	-	DN80	89
80FWC-V-54-5,5T	6,6	5,5	7,5	400	11,7	3 -	10	4G2,5+3x1	-	DN80	100

"-" = not available

• = available

HYDRAULIC PERFORMANCE AT 50 HZ

Pump model	Phase	Q = Delivery															
		l/sec 0	6	8	10	12	14	16	18	20	22	24	26	28	30	32	34
		m ³ /h 0	21,6	28,8	36	43,2	50,4	57,6	64,8	72	79,2	86,4	93,6	100,8	108	115,2	122,4
		US gpm 0	92,1	126,8	158,5	190,2	221,9	253,6	285,3	317	348,7	380,4	412,1	443,8	475,5	507,2	538,9
		H = Total meters head of water column [m]															
80FWC-V-54-1,6T	3 -	9	7,5	6,9	6,2	5,4	4,7	3,8	3	2,2							
80FWC-V-54-2,2T	3 -	10,5	8,8	8,3	7,6	6,9	6,3	5,5	4,7	3,7	2,7						
80FWC-V-54-3,1T	3 -	13	11,1	10,6	9,9	9,3	8,6	7,9	7,1	6,3	5,4	4,4	3,2	2			
80FWC-V-54-5,5T	3 -	16	14,1	13,6	12,8	12,3	11,7	11	10,3	9,5	8,7	7,8	6,9	5,8	4,8	3,5	2,3

HYDRAULIC PERFORMANCE AT 50 HZ

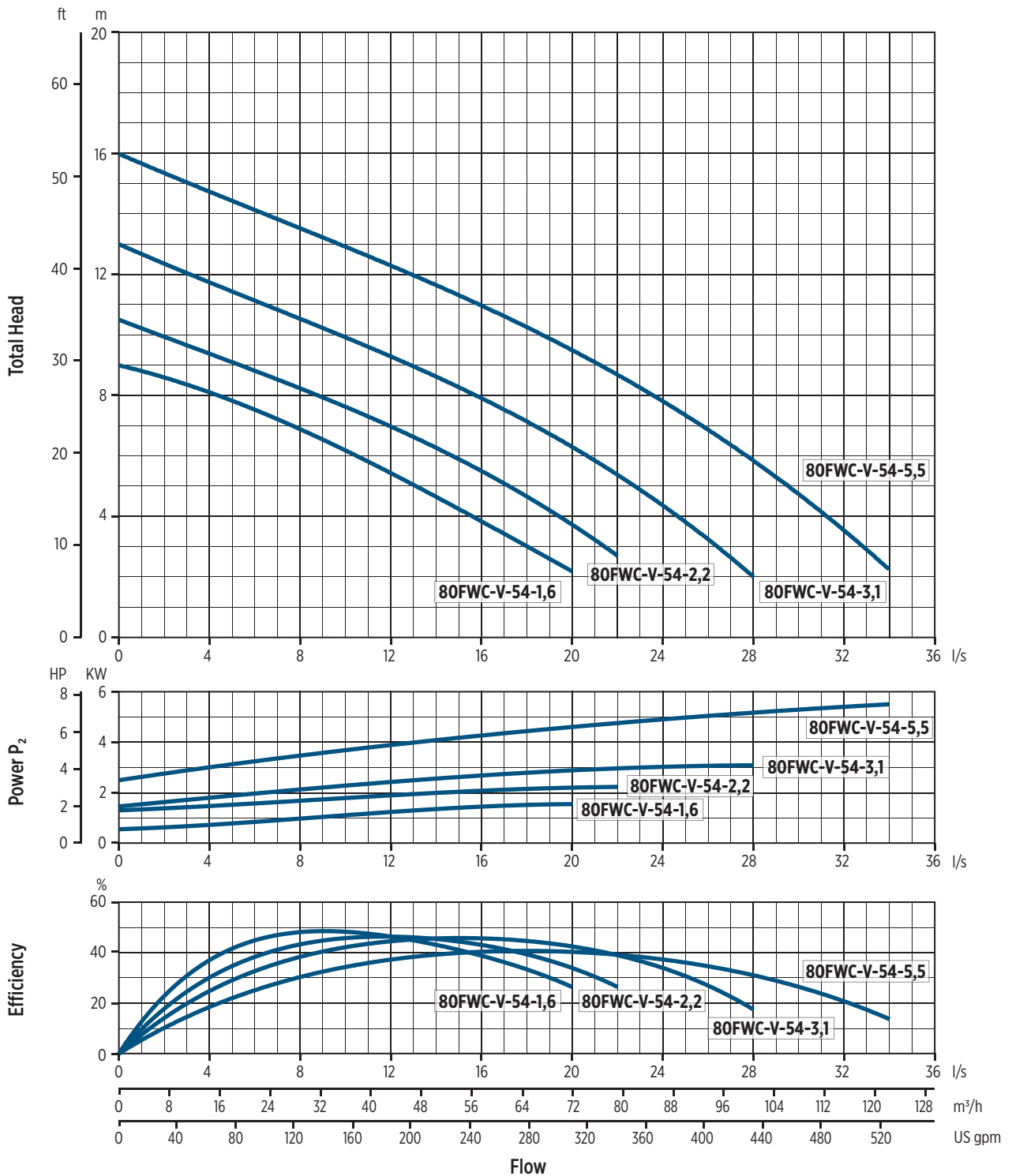

00201003.12/2022

INSTALLATION

INSTALLATION INSTRUCTIONS

PERMANENT INSTALLATION WITH COUPLING SYSTEM

It is the recommended installation for the permanent pumping station. The electric pump is guided by two pipes and it is connected automatically to the coupling system. The quick connection ensures that the pump can be easily removed and re-installed.

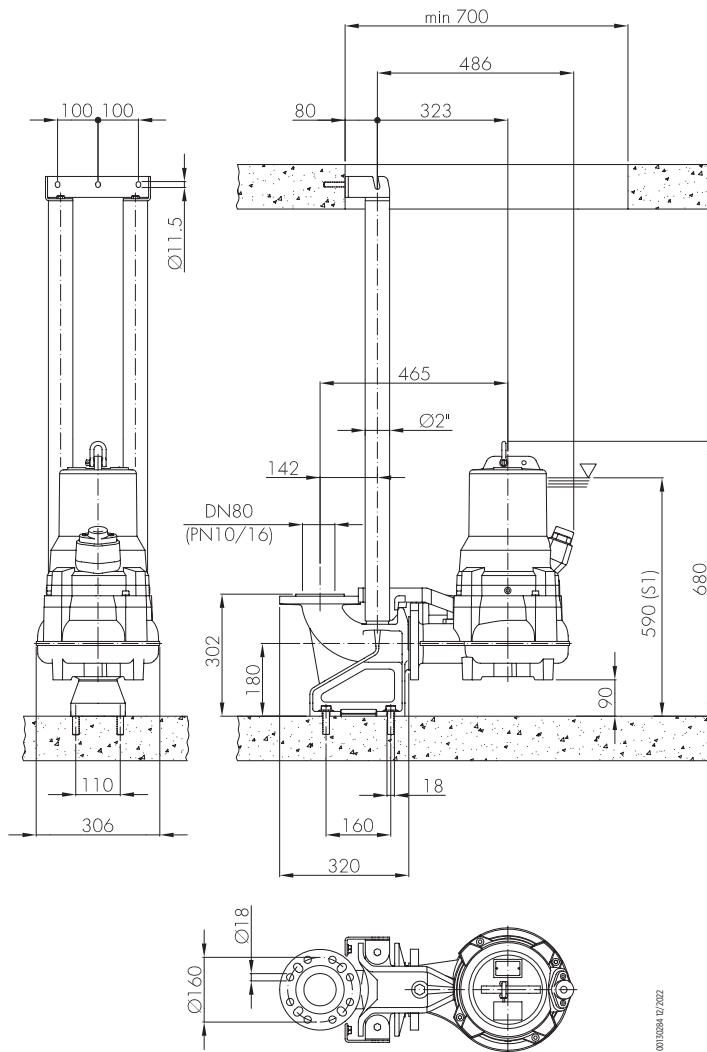

00120294 12/2022

TRANSPORTABLE INSTALLATION

Transportable as emergency pump with connection to the hose and for free installation in the well.

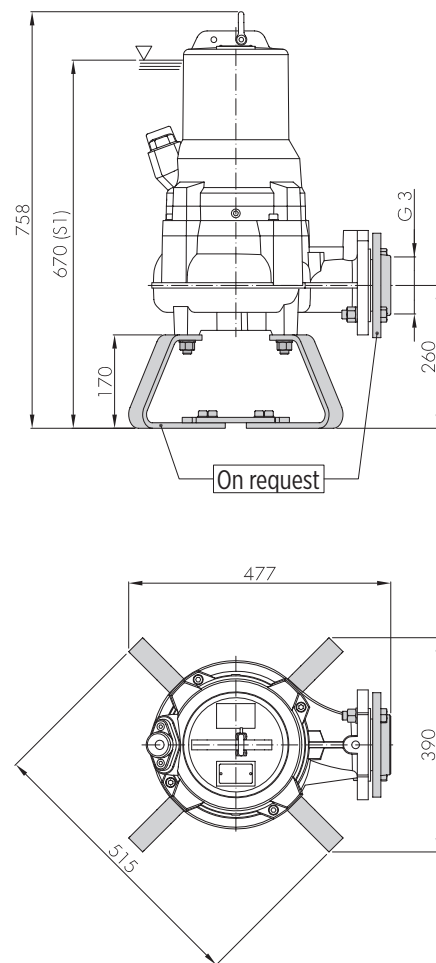

00120294 12/2022

100FWC M4 SERIES 50 HZ

FEATURES & BENEFITS

APPLICATIONS



Domestic / industrial grey water



Extraction of water from ponds, streams or pits and for rainwater collection



Wastewater



MARKETS



RESIDENTIAL



COMMERCIAL



INDUSTRY



AGRICULTURE

CAST IRON SUBMERSIBLE WASTEWATER LIFT PUMPS

Submersible electric pumps particularly suitable for pumping industrial sewage, screened waste water and mud in the pumping stations. They can be used also to lift clear and dirty water and rain water.

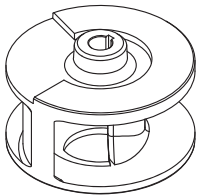

000000710/0002

SINGLE-CHANNEL IMPELLER

GENERAL FEATURES

		Materials/Constr.design
Vortex impeller		Cast iron EN GJS400
External casing		Cast iron EN GJL250
Pump body		Cast iron EN GJL250
Cover		Cast iron EN GJL250
	Mechanical seal	Graphite/Alumina
	pump side	Silicon carbide (SiC/SiC)
Motor shaft		Stainless steel AISI420
Power cable	Type	10 m SIRN8-F type
	100FWC-M-54-2,2T, 100FWC-M-54-3,1T	4G1,5+3x1mm ²
	100FWC-M-54-5,5T	4G2,5+3x1mm ²
		Motor
Constr.design		asynchronous squirrel cage-type in dry chamber
Type		4 poles; 50 Hz
Insulation class		F
Protection degree		IP68
Voltage	Three-phase	400V ±10%
Probe		Thermal in the winding
		Conductivity in the oil chamber
		Limits of use
Maximum liquid temperature		+40 °C
pH of pumped liquid		6 - 10
Liquid density		1,0 kg/dm ³
Maximum immersion depth:		5 m
Min. immersion depth for continuous service		517 mm
Free passage		80 mm
Max. number of starting/hour		20
		Construction options

- 60 Hz version
- Different voltages

DIMENSIONAL DRAWINGS

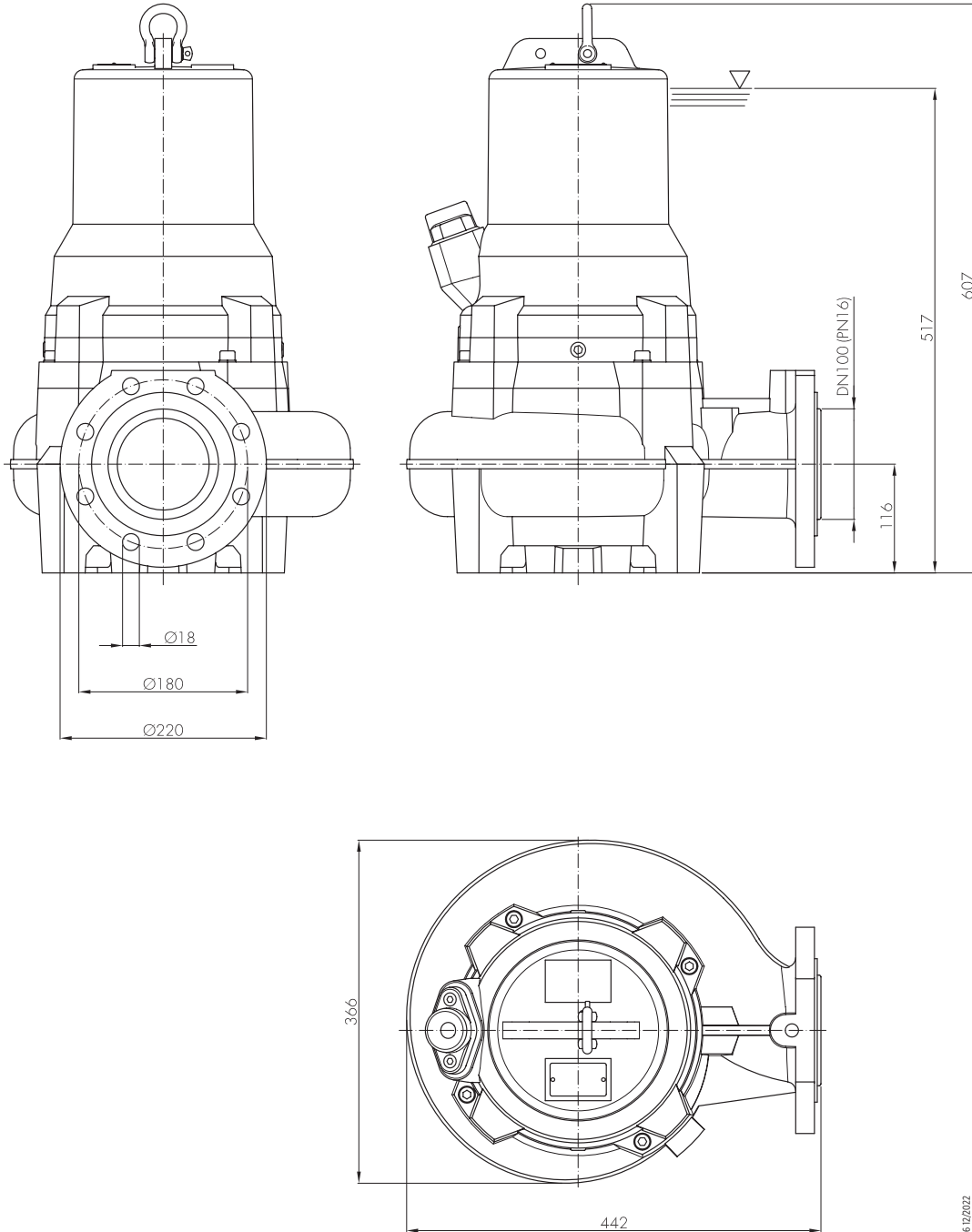

0030286 12/2022

Packaging		
Pump model	Dimensions [mm]	Weight [kg]
100FWC-M-54-2,2T	475x370x985	100
100FWC-M-54-3,1T	475x370x985	103
100FWC-M-54-5,5T	475x370x985	115

TECHNICAL DATA

Pump model	Motor absorbed power P ₁	Rated power P ₂		Voltage	Rated current	Phase	Power cable		Float switch	Delivery port	Weight [kg]
	[kW]	[kW]	[HP]	[V]	[A]		Length [m]	Type			
100FWC-M-54-2,2T	2,8	2,2	3	400	5,4	3 -	10	4G1,5+3x1	-	DN100	97
100FWC-M-54-3,1T	3,9	3,1	4,2	400	7,5	3 -	10	4G1,5+3x1	-	DN100	100
100FWC-M-54-5,5T	6,6	5,5	7,5	400	11,7	3 -	10	4G2,5+3x1	-	DN100	112

"-" = not available

• = available

HYDRAULIC PERFORMANCE AT 50 HZ

Pump model	Phase	Q = Delivery														
		l/sec 0	8	10	15	20	25	30	35	38	40	42,8	45	50	55	59
		m ³ /h 0	28,8	36	54	72	90	108	126	136,8	144	154,1	162	180	198	212,4
		US gpm 0	126,8	158,5	237,7	317	396,2	475,5	554,8	602,3	634	678,4	713,3	792,5	871,8	935,2
		H = Total meters head of water column [m]														
100FWC-M-54-2,2T	3 -	10,6	8,9	8,4	7,3	6,3	5,1	3,9	2,6	1,6						
100FWC-M-54-3,1T	3 -	12,7	11	10,5	9,4	8,4	7,2	6	4,5	3,6	3	2				
100FWC-M-54-5,5T	3 -	19	16	15,2	13,8	12,5	11,3	10,2	9,1	8,3	7,8	7,1	6,5	4,8	3	1,3

HYDRAULIC PERFORMANCE AT 50 HZ

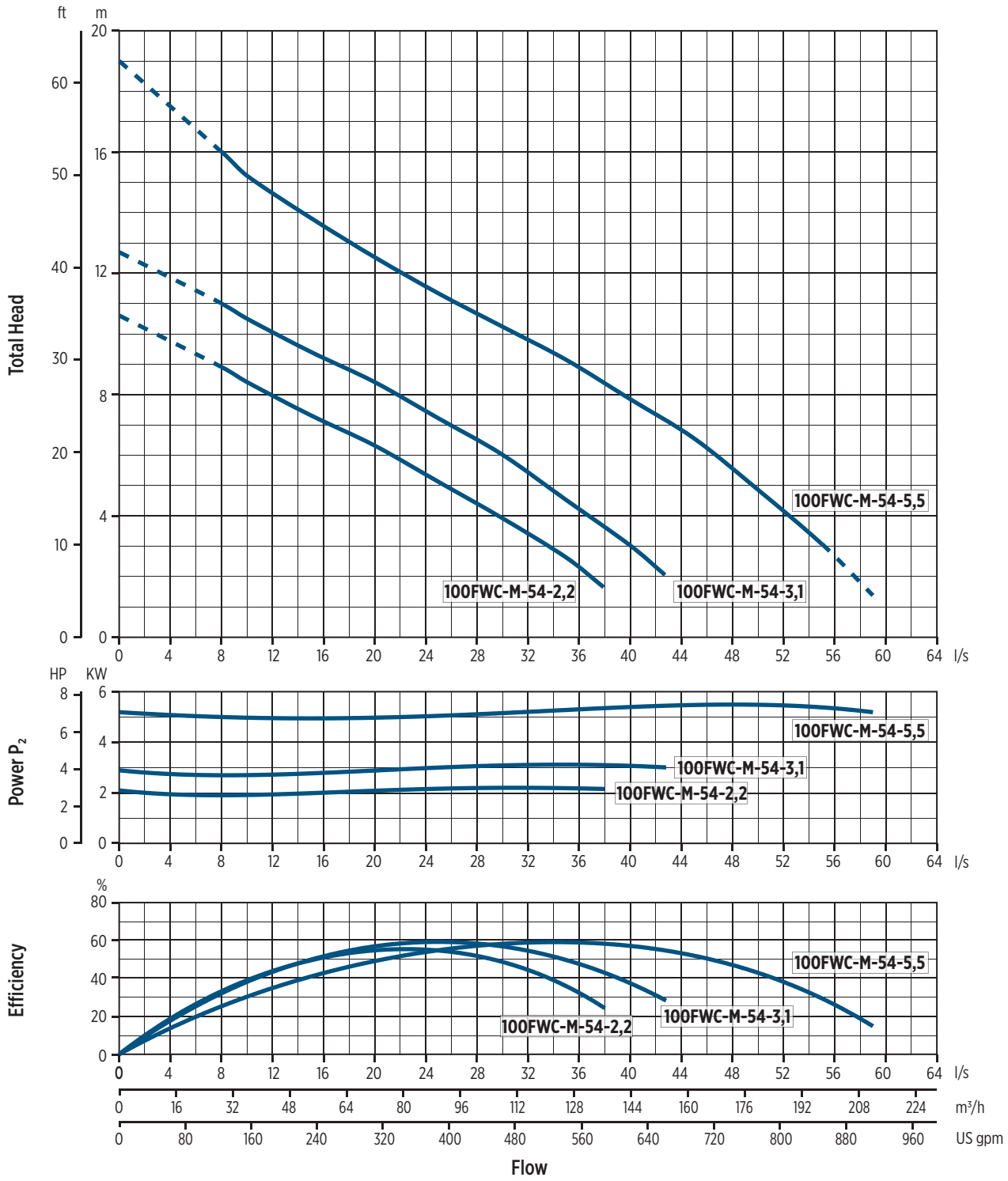

0020102 12/2022

INSTALLATION

INSTALLATION INSTRUCTIONS

PERMANENT INSTALLATION WITH COUPLING SYSTEM

It is the recommended installation for the permanent pumping station. The electric pump is guided by two pipes and it is connected automatically to the coupling system. The quick connection ensures that the pump can be easily removed and re-installed.

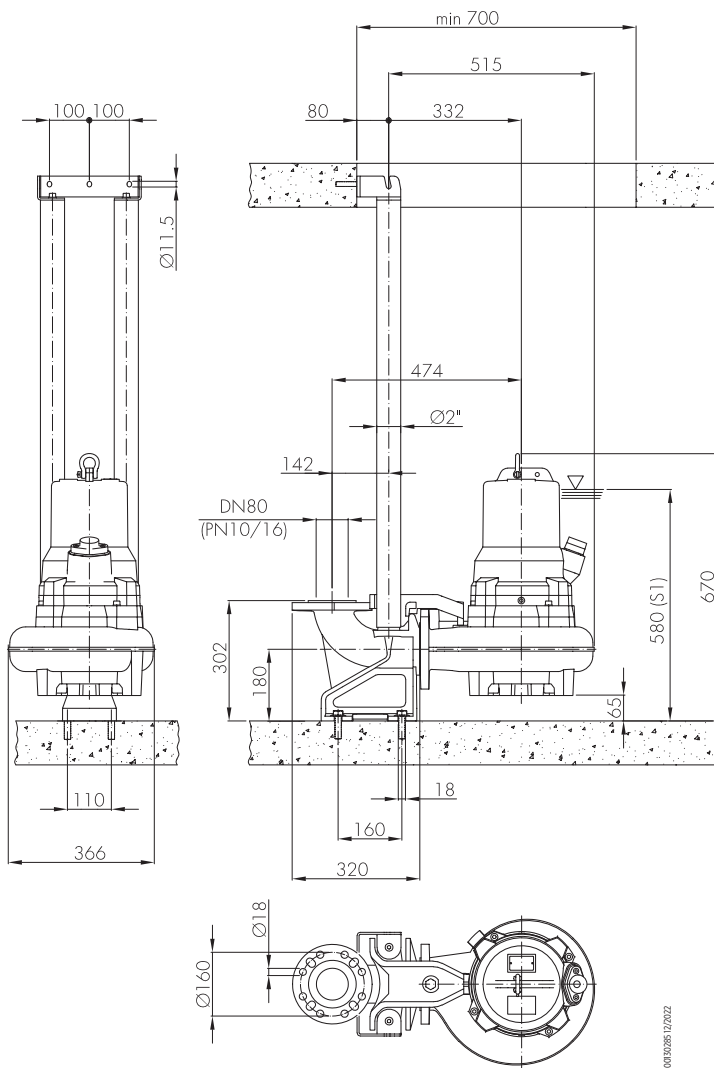

TRANSPORTABLE INSTALLATION

Transportable as emergency pump with connection to the hose and for free installation in the well.

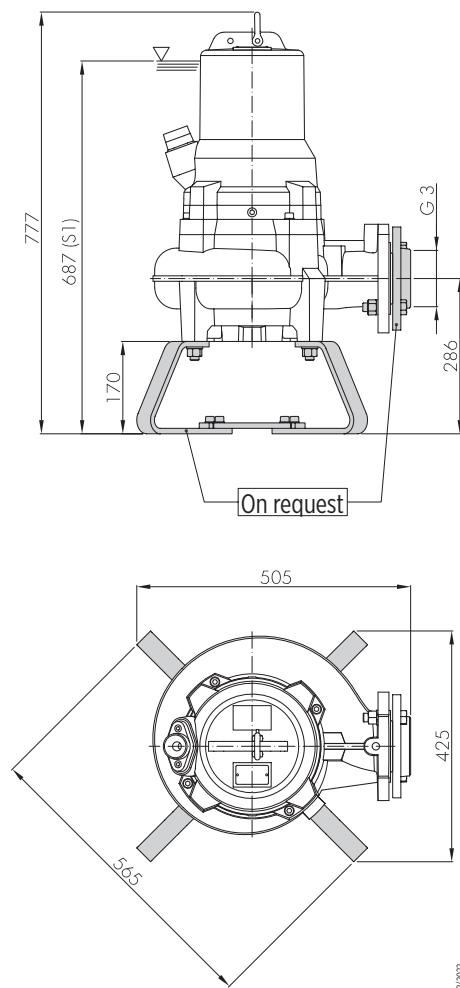

0050265/12/2022

328517/2022

FGR Series - Pumps with grinder unit 50 Hz



FGR SERIES - PUMPS WITH GRINDER UNIT 50 HZ

PUMP IDENTIFICATION CODE

40 | FGR - 5 | 2 - 1,8 | T - G

- “G” (Float switch)
- Phase: “M” (Single-phase), “T” (Three-phase)
- Power [kW]
- N. of poles: “2” (2 poles)
- Frequency: “5” (50 Hz), “6” (60 Hz)
- Model: FGR (Franklin Grinder)
- Ø delivery [mm]

00140087 01/2023



40FGR SERIES 50 HZ

FEATURES & BENEFITS

APPLICATIONS



Pumping of clear non-loaded fluids



Extraction of water from ponds, streams or pits and for rainwater collection



Wastewater



MARKETS



CAST IRON SUBMERSIBLE WASTEWATER LIFT PUMPS WITH GRINDER UNIT

These series of grinder pumps are particularly used in civil and industrial sewage plants. They have been designed to pump the liquid at high head with very low capacity. The cutter unit, in a special hard stainless steel, cuts into small pieces threadlike materials contained in the liquids. As the risk of clogging is avoided small diameter pipes are used. These pumps can be used to lift the sewage of blocks of flats and villas, small isolated areas far from the sewer systems; the sewage of hotels and campsites, in the food and paper industry and in those particular situations where the installation is often expensive by using a gravity system.

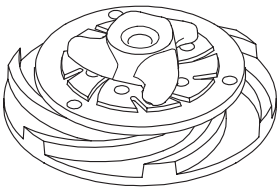

IMPELLER WITH GRINDER UNIT

GENERAL FEATURES

Materials/Constr.design		
Impeller with grinder unit		Cast iron EN GJL200
External casing		Stainless steel AISI304
Pump body		Cast iron EN GJL200
Cover		Cast iron EN GJL200
Grinder unit		Hardened stainless steel
Mechanical seal	motor side	Seal ring
	pump side	Silicon carbide (SiC/SiC)
Motor shaft		Stainless steel AISI416
Power cable	Type	10 m H07RN-F type
	Single-phase	4G1mm ² with SHUKO plug (CEE7/VII), box with manual overload cut-out and with starting and operating capacitors.
	Three-phase	4G1mm ²
Motor		
Constr.design		asynchronous squirrel cage-type in dry chamber
Type		2 poles; 50 Hz
Insulation class		F
Protection degree		IP68
Voltage	Single-phase	230V ±6% built-in overheating protection, float switch as optional
	Three-phase	230V ±10%, 400V ±10%
Limits of use		
Maximum liquid temperature		+40 °C
pH of pumped liquid		6 - 10
Liquid density		1,0 kg/dm ³
Maximum immersion depth:		5 m
Min. immersion depth for continuous service		303 mm
Max. number of starting/hour		20
Construction options		

- 60 Hz version
- Different voltages

DIMENSIONAL DRAWINGS

Packaging		
Pump model	Dimensions [mm]	Weight [kg]
40FGR-52-0,75	255x205x560	18,7
40FGR-52-1,1	255x205x560	20,7

Pallet			
Pump model	Dimensions [mm]	N° of pumps	Weight [kg]
40FGR-52-0,75	800x1200x900	32	600
40FGR-52-1,1	800x1200x900	32	670

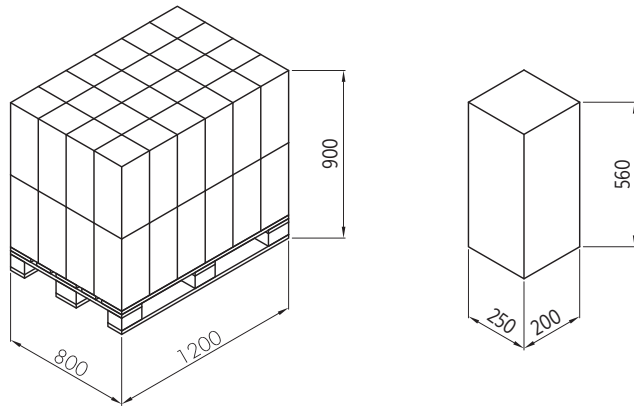

001029102/2023

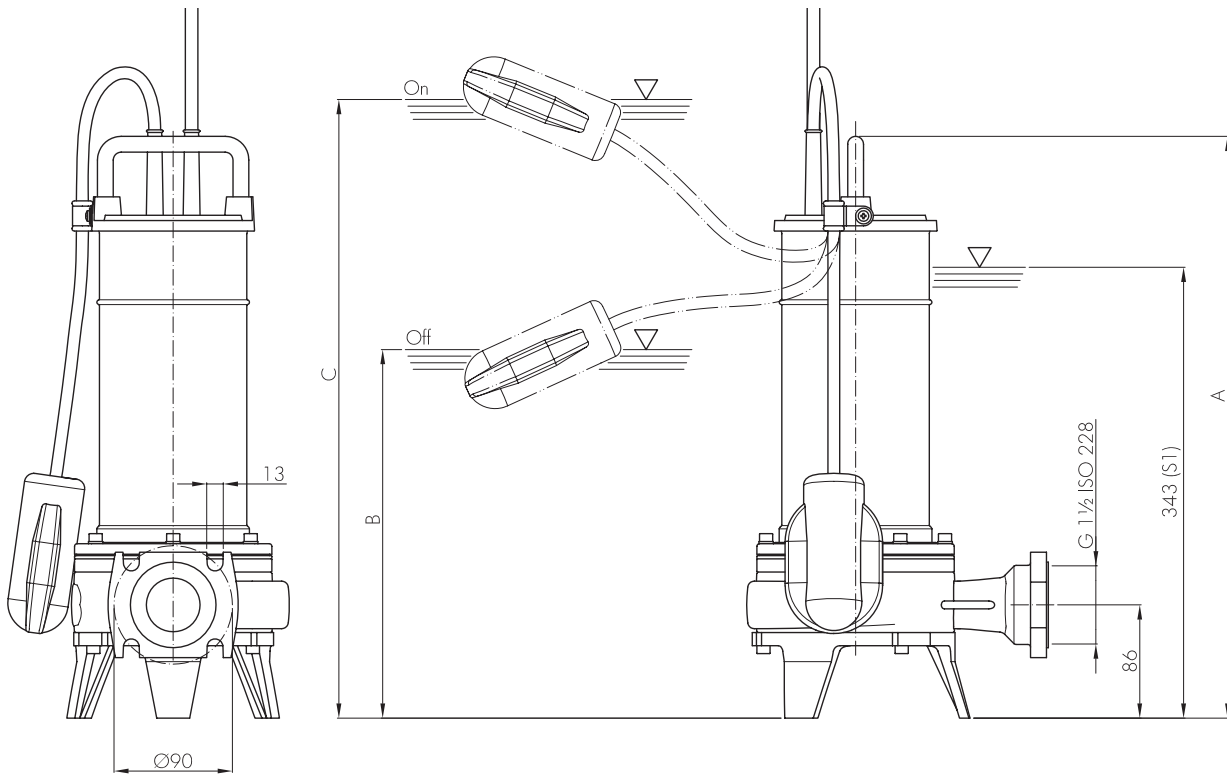

Dimensions [mm]			
Pump model	A	B	C
40FGR-52-0,75	438	280	470
40FGR-52-1,1	463	305	495

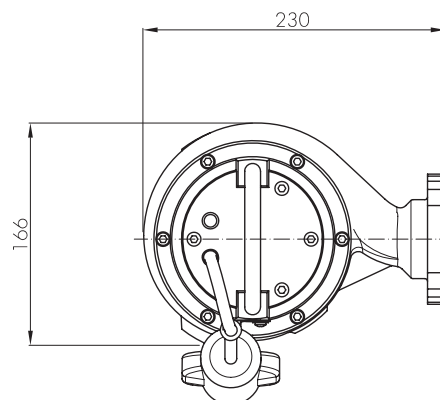

001029102/2023

TECHNICAL DATA

Pump model	Motor absorbed power P ₁	Rated power P ₂		Voltage [V]	Rated current [A]	Phase	Power cable		Float switch	Running capacitor [μF]	Delivery port	Weight [kg]
	[kW]	[kW]	[HP]				Length [m]	Type				
40FGR-52-0,75M	0,9	0,75	1	230	4,8	1 ~	10	4G1	-	20	G1½	18
40FGR-52-0,75M-G	0,9	0,75	1	230	4,8	1 ~	10	4G1	•	20	G1½	18
40FGR-52-0,75T	0,9	0,75	1	400	1,8	3 ~	10	4G1	-	-	G1½	18
40FGR-52-1,1M	1,4	1,1	1,5	230	6	1 ~	10	4G1	-	25	G1½	20
40FGR-52-1,1M-G	1,4	1,1	1,5	230	6	1 ~	10	4G1	•	25	G1½	20
40FGR-52-1,1T	1,4	1,1	1,5	400	2,1	3 ~	10	4G1	-	-	G1½	20

"-" = not available

• = available

HYDRAULIC PERFORMANCE AT 50 HZ

Pump model	Phase	Q = Delivery							
		l/sec 0	0,5	1	1,5	2	2,5	3	3,5
		m ³ /h 0	1,8	3,6	5,4	7,2	9	10,8	12,6
		US gpm 0	7,9	15,8	23,7	31,7	39,6	47,5	55,5
		H = Total meters head of water column [m]							
40FGR-52-0,75	1 ~	18,5	17,4	16,2	14	11,6	8,5	1,3	
	3 ~	18,5	17,4	16,2	14	11,6	8,5	1,3	
40FGR-52-1,1	1 ~	21	19,7	18,5	16,6	14,2	11,2	7,8	1
	3 ~	21	19,7	18,5	16,6	14,2	11,2	7,8	1

PERFORMANCE CURVES AT 50 HZ

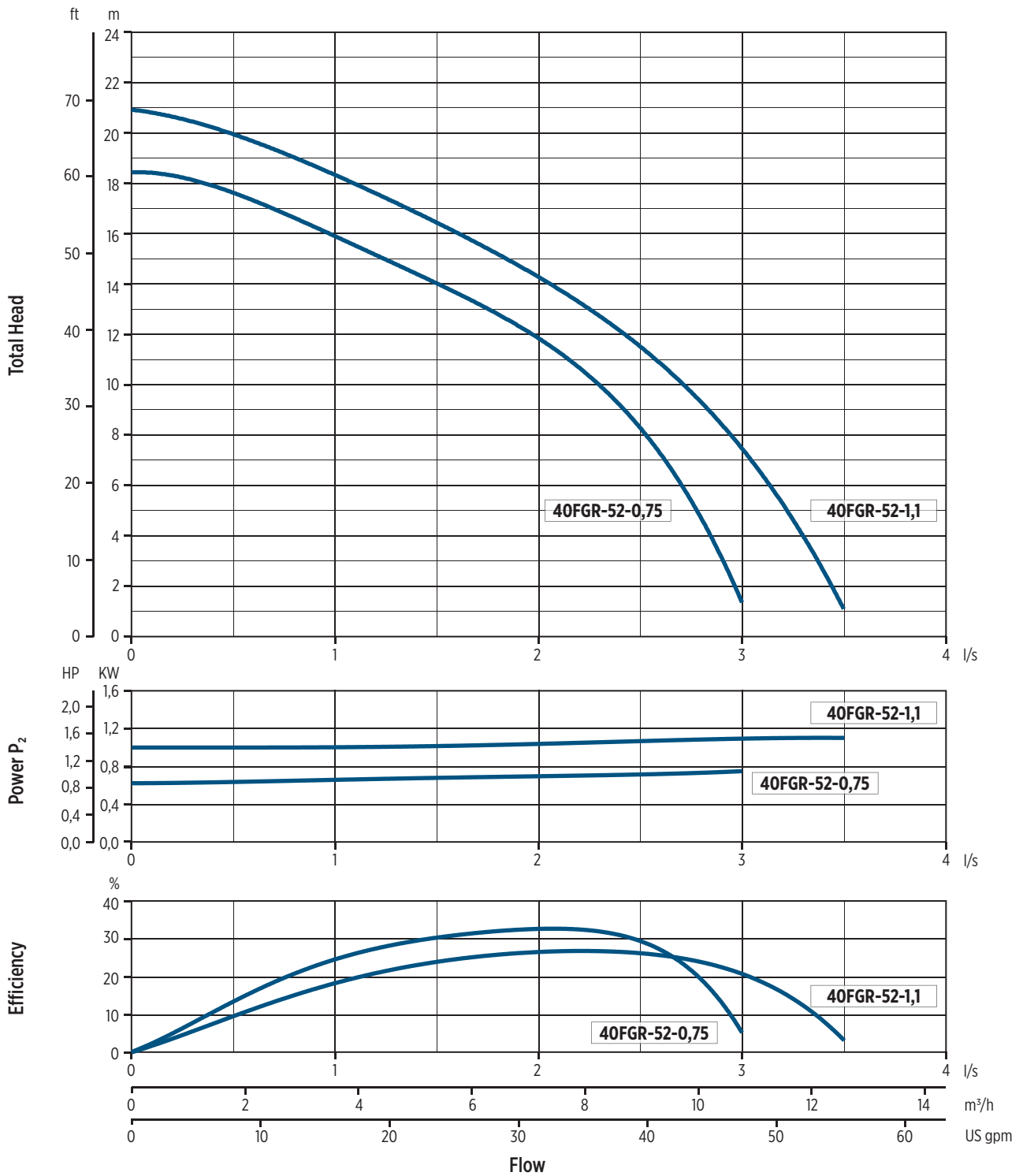

00202005 02/2023

INSTALLATION

INSTALLATION INSTRUCTIONS

PERMANENT INSTALLATION WITH COUPLING SYSTEM

It is the recommended installation for the permanent pumping station. The electric pump is guided by two pipes and it is connected automatically to the coupling system. The quick connection ensures that the pump can be easily removed and re-installed.

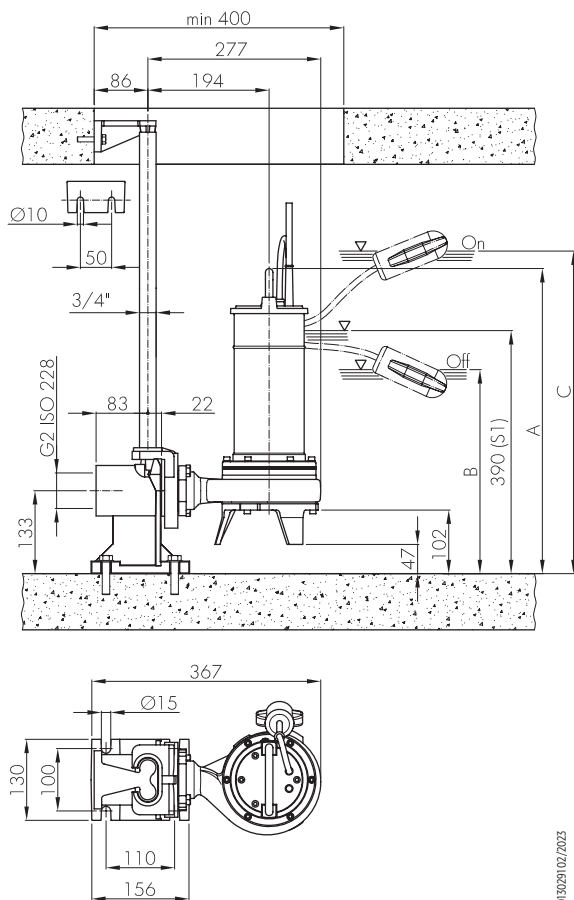

TRANSPORTABLE INSTALLATION

Transportable as emergency pump with connection to the hose and for free installation in the well.

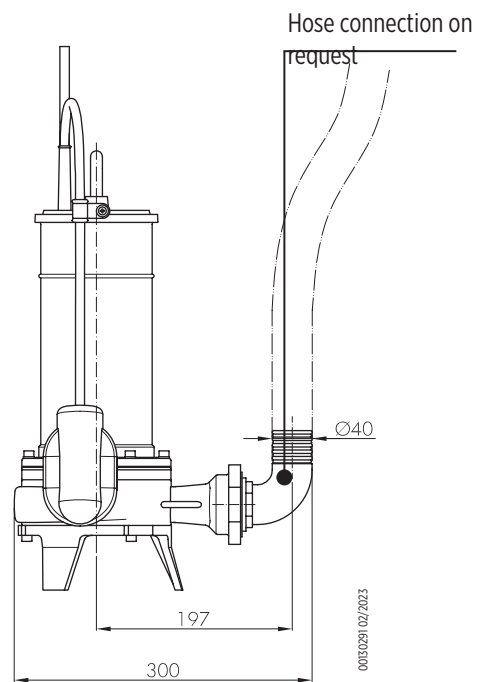

Pump model	Installation Dimensions [mm]		
	A	B	C
40FGR-52-0,75	485	330	515
40FGR-52-1,1	510	355	540

50FGR SERIES 50 HZ

FEATURES & BENEFITS

APPLICATIONS



Pumping of clear non-loaded fluids



Extraction of water from ponds, streams or pits and for rainwater collection



Wastewater



MARKETS

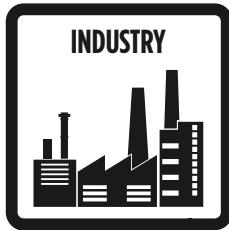

CAST IRON SUBMERSIBLE WASTEWATER LIFT PUMPS WITH GRINDER UNIT

These series of grinder pumps are particularly used in civil and industrial sewage plants. They have been designed to pump the liquid at high head with very low capacity. The cutter unit, in a special hard stainless steel, cuts into small pieces threadlike materials contained in the liquids. As the risk of clogging is avoided small diameter pipes are used. These pumps can be used to lift the sewage of blocks of flats and villas, small isolated areas far from the sewer systems; the sewage of hotels and campsites, in the food and paper industry and in those particular situations where the installation is often expensive by using a gravity system.

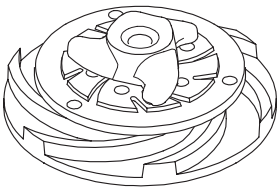

IMPELLER WITH GRINDER UNIT

GENERAL FEATURES

Materials/Constr.design		
Impeller with grinder unit		Cast iron EN GJL200
External casing		Cast iron EN GJL200
Pump body		Cast iron EN GJL200
Cover		Cast iron EN GJL200
Grinder unit		Stainless steel AISI431
Mechanical seal	motor side	Graphite/Alumina
	pump side	Silicon carbide (SiC/SiC)
Motor shaft		Stainless steel AISI431
Power cable	Type	10 m H07RN-F type
	Single-phase	4G1mm ² with SHUKO plug (CEE7/VII), box with manual overload cut-out and with starting and operating capacitors.
	Single-phase 50FGR-52-1,6M	4G2,5mm ² with SHUKO plug (CEE7/VII), box with manual overload cut-out and with starting and operating capacitors.
	Three-phase	4G1,5mm ²
Motor		
Constr.design		asynchronous squirrel cage-type oil filled
Type		2 poles; 50 Hz
Insulation class		F
Protection degree		IP68
Voltage	Single-phase	230V ±6% built-in overheating protection (up to 1,1 kW), float switch as optional
	Three-phase	230V ±10%, 400V ±10%
Limits of use		
Maximum liquid temperature		+40 °C
pH of pumped liquid		6 - 10
Liquid density		1,0 kg/dm ³
Maximum immersion depth:		5 m
Min. immersion depth for continuous service		
50FGR-52-1,1M/T		373 mm
50FGR-52-1,6M/T / 50FGR-52-2,2T		440 mm
Max. number of starting/hour		20
Construction options		

- 60 Hz version
- Different voltages
- Food-grade white oil

DIMENSIONAL DRAWINGS

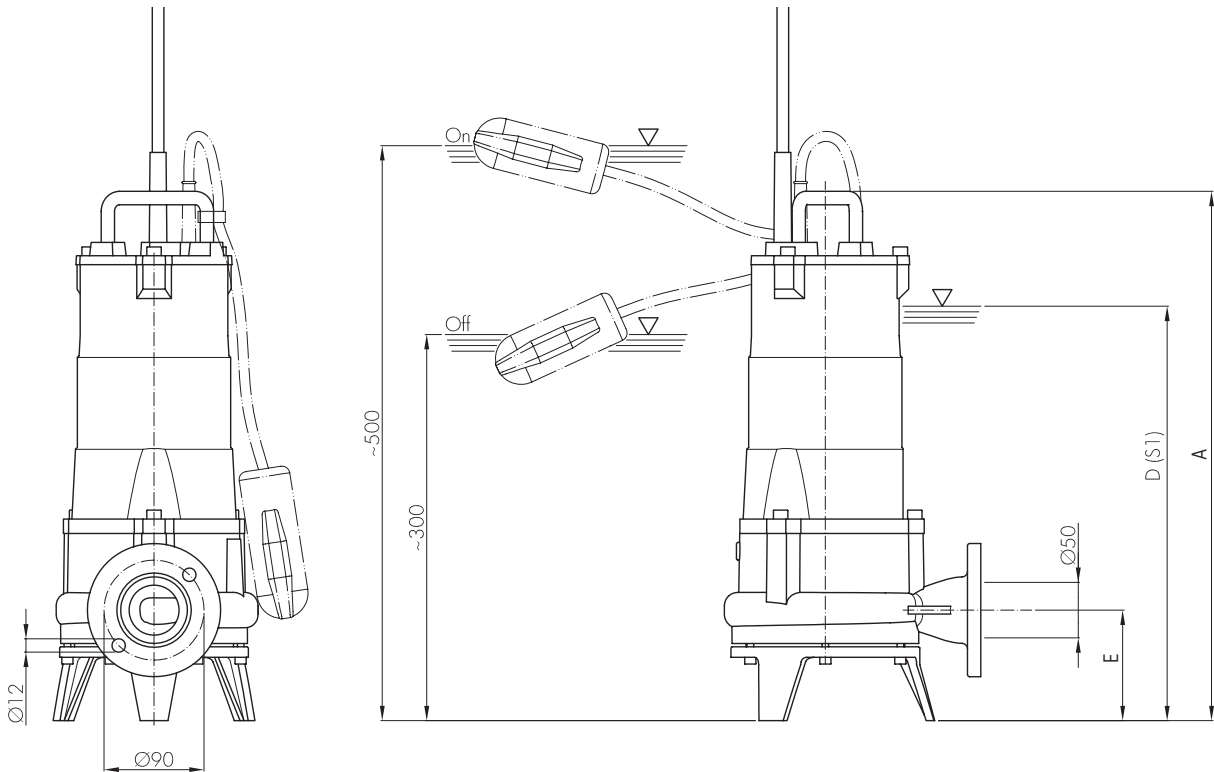

Pump model	Dimensions [mm]				
	A	D	E	F	G
50FGR-52-1,1	477	373	100	185	231
50FGR-52-1,6	550	440	110	220	276
50FGR-52-2,2	550	440	110	220	276

Pump model	Packaging	
	Dimensions [mm]	Weight [kg]
50FGR-52-1,1	290x245x585	35
50FGR-52-1,6	300x260x585	41
50FGR-52-2,2	300x260x585	43

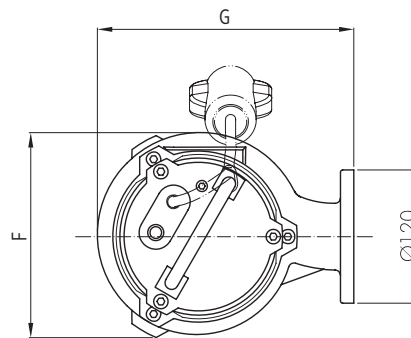

00150294 02/2023

TECHNICAL DATA

Pump model	Motor absorbed power P ₁	Rated power P ₂		Voltage [V]	Rated current [A]	Phase	Power cable		Float switch	Running capacitor [μF]	Delivery port	Weight [kg]
	[kW]	[kW]	[HP]				Length [m]	Type				
50FGR-52-1,1M	1,4	1,1	1,5	230	7	1 -	10	4G1,5	-	30	G2 (Ø50)	34
50FGR-52-1,1M-G	1,4	1,1	1,5	230	7	1 -	10	4G1,5	•	30	G2 (Ø50)	34
50FGR-52-1,1T	1,4	1,1	1,5	400	11	3 -	10	4G2,5	•	-	G2 (Ø50)	34
50FGR-52-1,1T-G	1,4	1,1	1,5	400	11	3 -	10	4G2,5	-	-	G2 (Ø50)	34
50FGR-52-1,6M	2,3	1,6	2,1	230	3	1 -	10	4G1,5	-	40	G2 (Ø50)	40
50FGR-52-1,6M-G	2,3	1,6	2,1	230	3	1 -	10	4G1,5	•	40	G2 (Ø50)	40
50FGR-52-1,6T	2,3	1,6	2,1	400	4	3 -	10	4G1,5	-	-	G2 (Ø50)	40
50FGR-52-1,6T-G	2,3	1,6	2,1	400	4	3 -	10	4G1,5	•	-	G2 (Ø50)	40
50FGR-52-2,2T	3,1	2,2	3	400	5	3 -	10	4G1,5	-	-	G2 (Ø50)	42

"-" = not available

• = available

HYDRAULIC PERFORMANCE AT 50 HZ

Pump model	Phase	Q = Delivery										
		l/sec 0	0,5	1	1,5	2	2,5	3	3,5	4	4,5	5
		m ³ /h 0	1,8	3,6	5,4	7,2	9	10,8	12,6	14,4	16,2	18
		US gpm 0	7,9	15,8	23,7	31,7	39,6	47,5	55,5	63,4	71,3	79,2
		H = Total meters head of water column [m]										
50FGR-52-1,1	1 -	21	19	17	15,8	14	12	9,5	8,8	7,8	5,8	2
	3 -	21	19	17	15,8	14	12	9,5	8,8	7,8	5,8	2
50FGR-52-1,6	1 -	27	25	21	20,5	19	18	15,5	14,5	13	10	5
	3 -	27	25	21	20,5	19	18	15,5	14,5	13	10	5
50FGR-52-2,2	3 -	34	32	29,5	27,5	25,7	23,8	22	20	17,5	15	10

PERFORMANCE CURVES AT 50 HZ

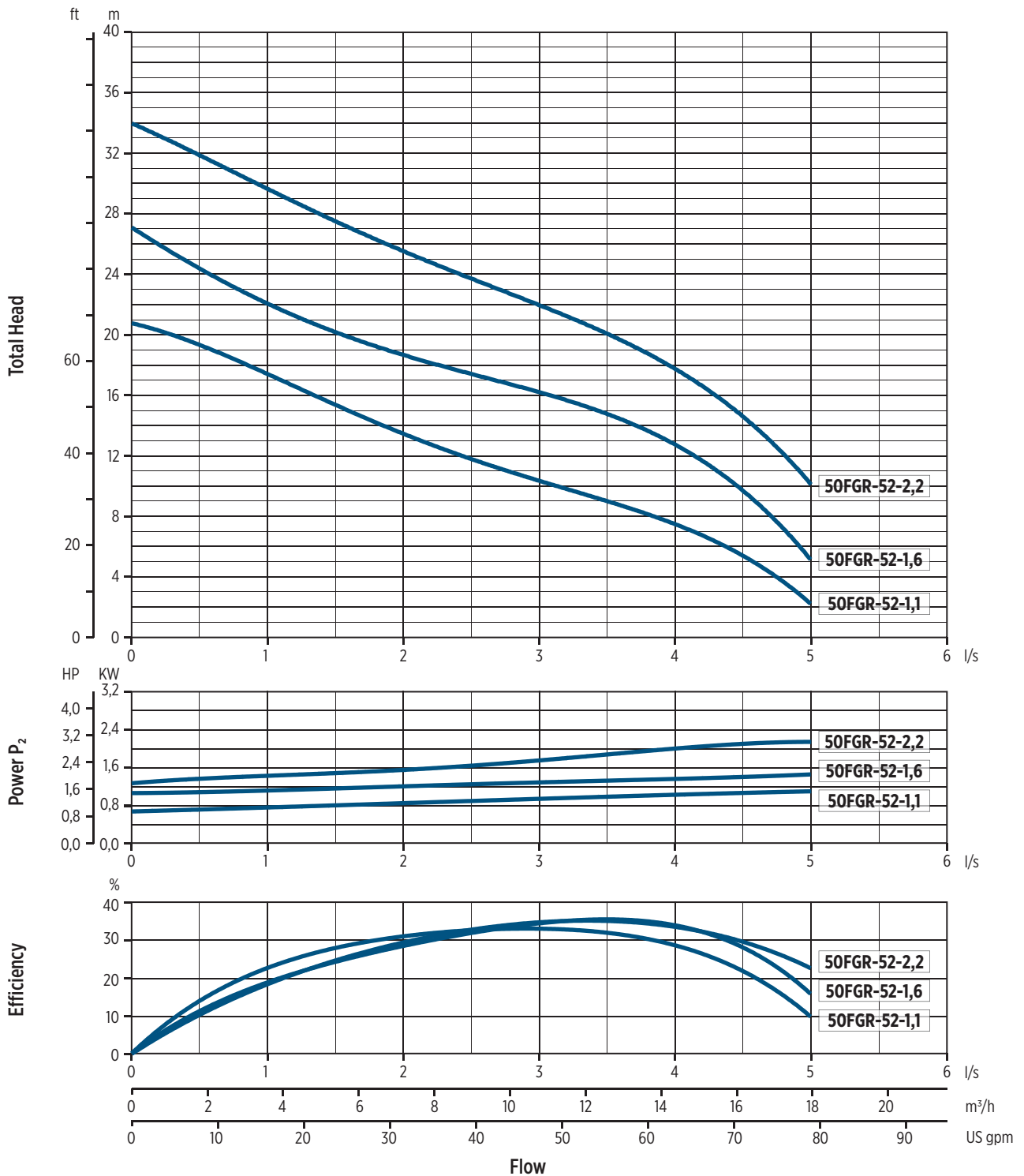

00201014_02/2023

INSTALLATION

INSTALLATION INSTRUCTIONS

PERMANENT INSTALLATION WITH COUPLING SYSTEM

It is the recommended installation for the permanent pumping station. The electric pump is guided by two pipes and it is connected automatically to the coupling system. The quick connection ensures that the pump can be easily removed and re-installed.

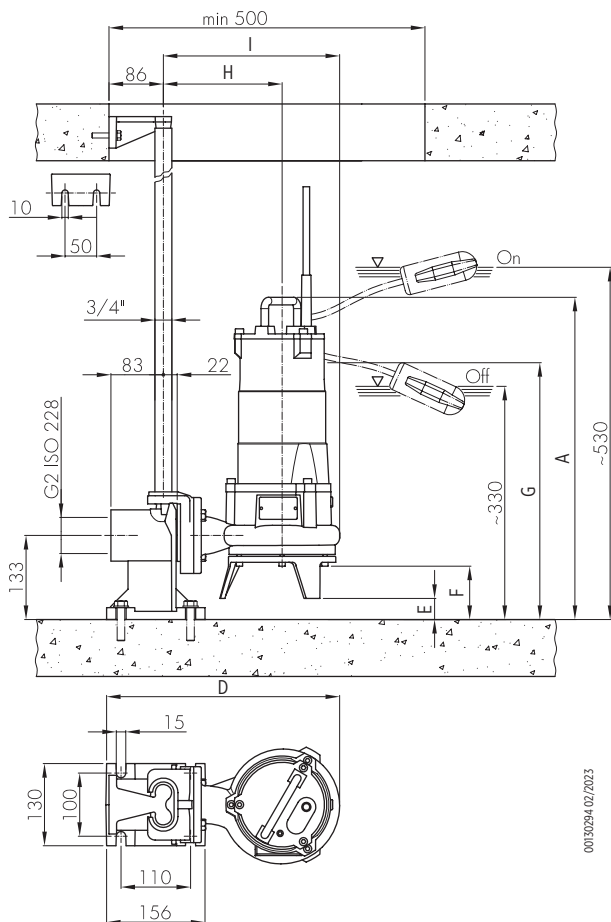

00130294 02/2023

TRANSPORTABLE INSTALLATION

Transportable as emergency pump with connection to the hose and for free installation in the well.

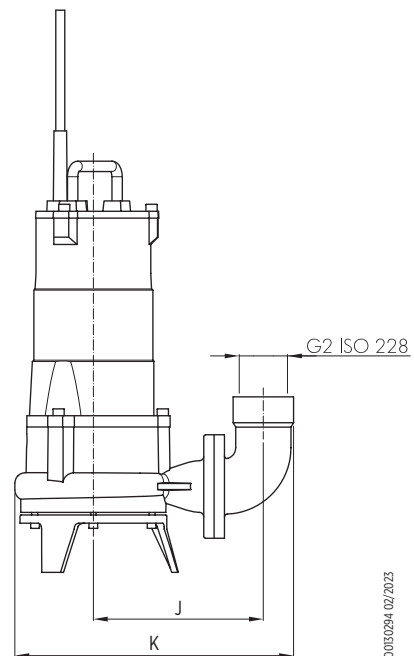

00130294 02/2023

Pump model	Installation Dimensions [mm]								
	A	D	E	F	G	H	I	J	K
50FGR-52-1,1	510	370	34	85	407	193	279	197	232
50FGR-52-1,6	574	414	24	76	464	215	324	224	368
50FGR-52-2,2	574	414	24	76	464	215	324	224	368

FLV Series - D.C. motor submersible waste water lift pumps 50 Hz



D.C. MOTOR SUBMERSIBLE WASTE WATER LIFT PUMPS

PUMP IDENTIFICATION CODE

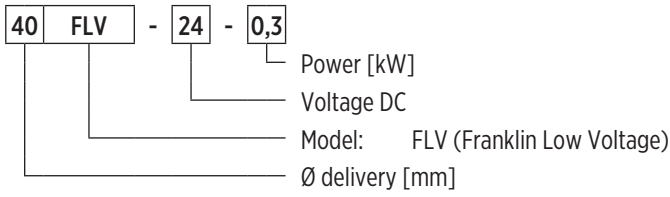

0040088 01/2023



40FLV SERIES

FEATURES & BENEFITS

APPLICATIONS



drainage



Domestic / industrial
grey water



MARKETS



D.C. MOTOR SUBMERSIBLE WASTE WATER LIFT PUMPS

The D.C. electric submersible pumps are suitable for the drainage of water from road drain wells, basements and from sites where the electric current is not available. Easy to install and silent, this model offer the maximum safety.

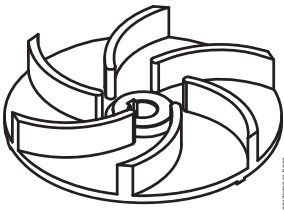

VORTEX IMPELLER

GENERAL FEATURES

Materials/Constr.design		
Vortex impeller		Cast iron EN GJL200
External casing		Stainless steel AISI304
Pump body		Cast iron EN GJL200
Cover		Cast iron EN GJL200
Mechanical seal	motor side 40FLV-24-0,3, 40FLV-24-0,5, 40FLV-24-0,75	Seal ring
	pump side 40FLV-24-0,3, 40FLV-24-0,5, 40FLV-24-0,75	Graphite/Alumina
	pump side 40FLV-12-0,3	Silicon carbide (SiC/SiC)
Motor shaft		Stainless steel AISI416
Power cable		5 m H07RN-F type, 2x6mm ²
Motor		
Constr.design		D.C. permanent magnet in dry chamber
Type		-
Insulation class		F
Protection degree		IP68
Main voltage values and relative tolerance in relation to the rated voltage value:		24V C.C. +10% / -5% 12V C.C. +10% / -5%
Limits of use		
Maximum liquid temperature		+40 °C
pH of pumped liquid		6 - 10
Liquid density		1,0 kg/dm ³
Maximum immersion depth:		2 m
Free passage		20 mm
Min. immersion depth for continuous service	40FLV-24-0,3, 40FLV-12-0,3,40FLV-24-0,5	300 mm
	40FLV-24-0,75	350 mm
Max. number of starting/hour		20
Construction options		

- Mechanical seal in Silicon carbide (SiC/SiC)
- Model 40FLV-12-0,3 with 10 m 1x16mm² cable and battery clamps
- Inlet with strainer (free passage 8 mm)

DIMENSIONAL DRAWINGS

Packaging		
Pump model	Dimensions [mm]	Weight [kg]
40FLV-24-0,3	220x180x450	11,5
40FLV-24-0,5	220x180x450	12,5
40FLV-24-0,75	220x200x450	17,7
40FLV-12-0,3	220x180x450	11,5

Pallet			
Pump model	Dimensions [mm]	N° of pumps	Weight [kg]
40FLV-24-0,3	800x1200x800	32	400
40FLV-24-0,5	800x1200x800	32	440
40FLV-24-0,75	800x1200x900	24	460
40FLV-12-0,3	800x1200x800	32	400

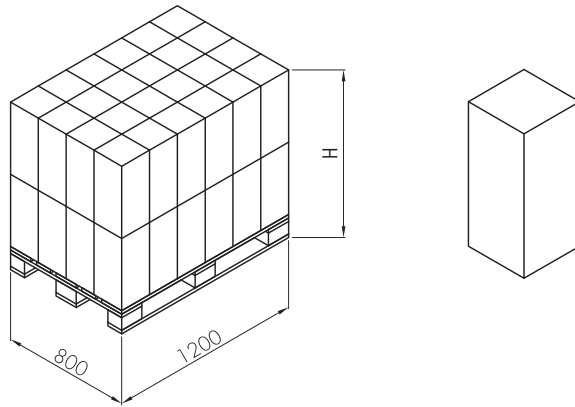

00130295 02/2023

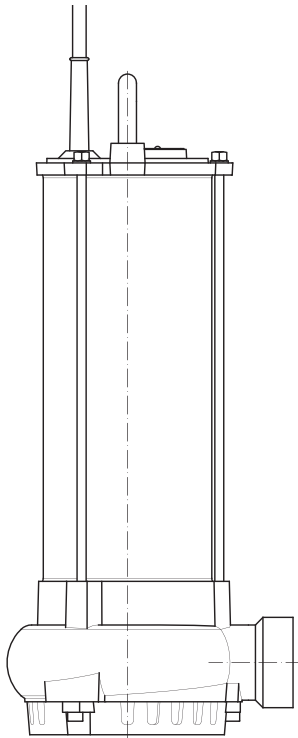

Version with filter on request

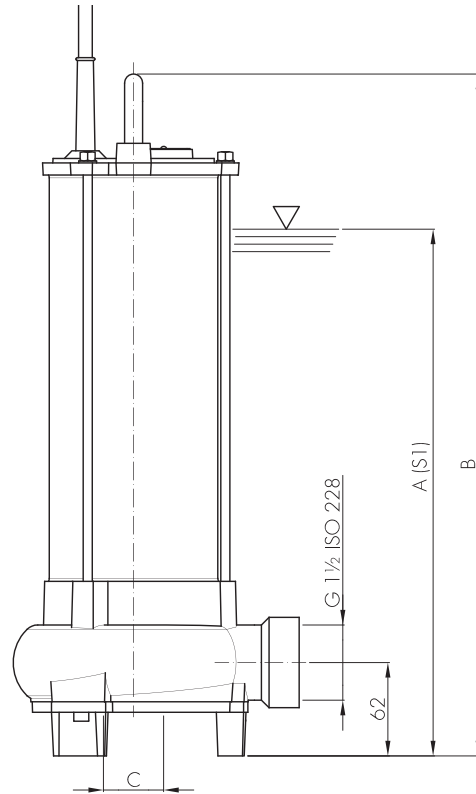

Dimensions [mm]			
Pump model	A	B	C
40FLV-24-0,3	300	402	30
40FLV-24-0,5	300	402	30
40FLV-24-0,75	350	453	40
40FLV-12-0,3	300	402	30

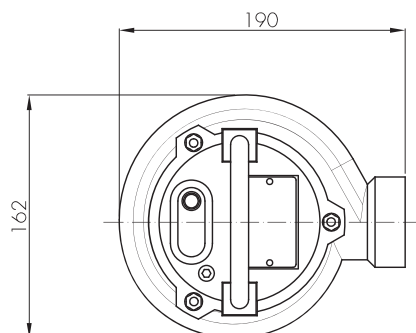

00130295 02/2023

TECHNICAL DATA

Pump model	Motor absorbed power P ₁	Rated power P ₂		Voltage	Rated current	Power cable		Delivery port	Weight [kg]
	[kW]	[kW]	[HP]	[V]	[A]	Length [m]	Type		
40FLV-24-0,3	0,4	0,3	0,4	24CC	17	5	2X6	G1½	11
40FLV-24-0,5	0,62	0,5	0,7	24CC	26	5	2X6	G1½	12
40FLV-24-0,75	0,84	0,75	1	24CC	35	5	2X6	G1½	17
40FLV-12-0,3	0,4	0,3	0,4	12CC	34	5	2X6	G1½	11

“-” = not available

• = available

HYDRAULIC PERFORMANCE AT 50 HZ

Pump model	Voltage	Q = Delivery											
		l/sec 0	0,5	1	1,5	2	2,5	3	3,5	4	4,5	5	5,5
		m ³ /h 0	1,8	3,6	5,4	7,2	9	10,8	12,6	14,4	16,2	18	19,8
	US gpm 0	7,9	15,8	23,7	31,7	39,6	47,5	55,5	63,4	71,3	79,2	87,2	
[V]	H = Total meters head of water column [m]												
40FLV-24-0,3	24CC	8	7	6,2	5,3	4,3	3,2	2,1	1				
40FLV-24-0,5	24CC	10,9	9,7	8	7,1	6,8	6	5	3,9	2,9	1,5		
40FLV-24-0,75	24CC	12	11	10	9	8	7	5,8	5,1	4,5	3,9	3	2
40FLV-12-0,3	12CC	7,5	7	6	5	4	3,1	2,5	2	0,8			

PERFORMANCE CURVES AT 50 HZ

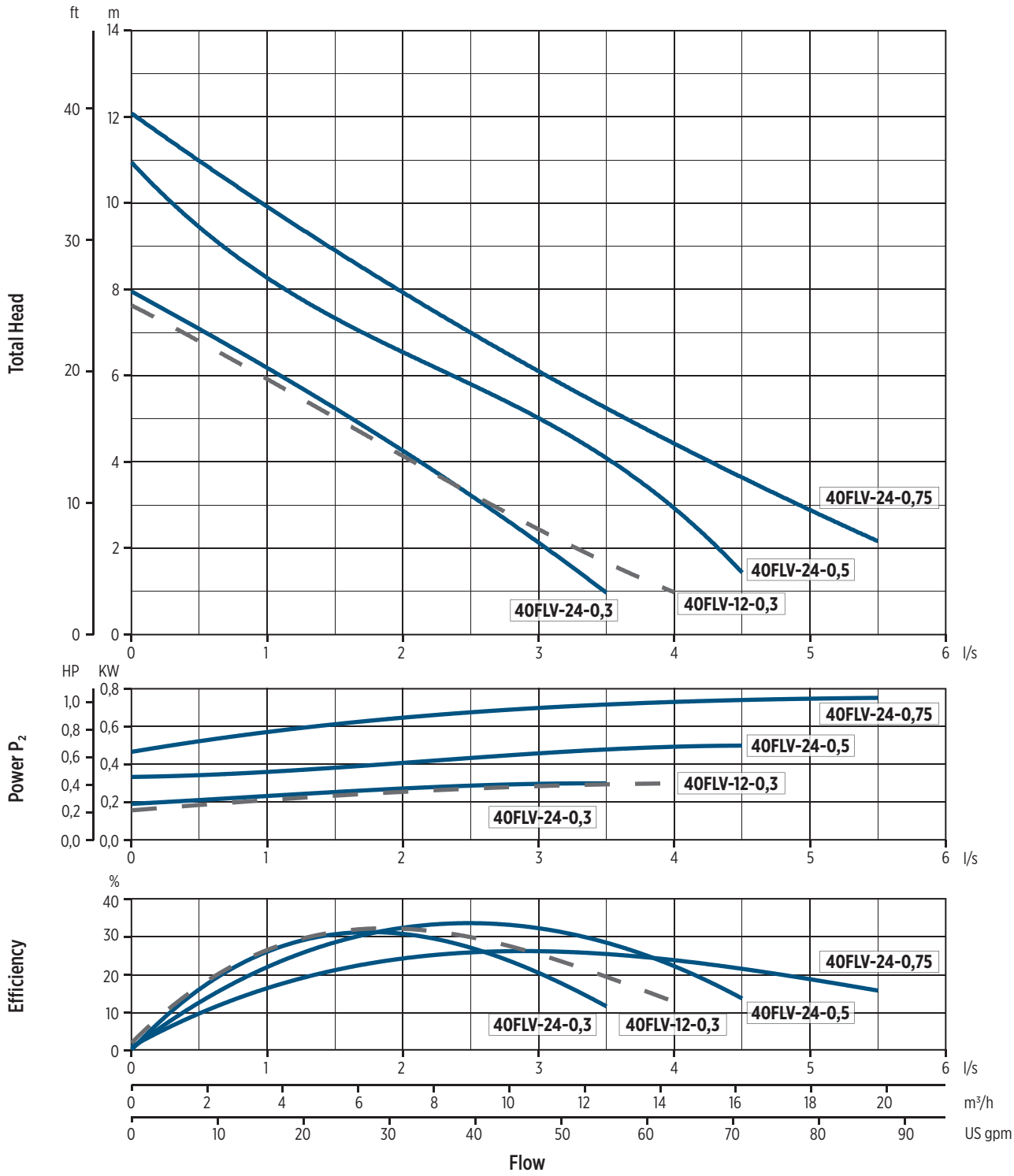

00201005 02/2023

INSTALLATION

INSTALLATION INSTRUCTIONS

TRANSPORTABLE INSTALLATION

Transportable as emergency pump with connection to the hose and for free installation in the well.

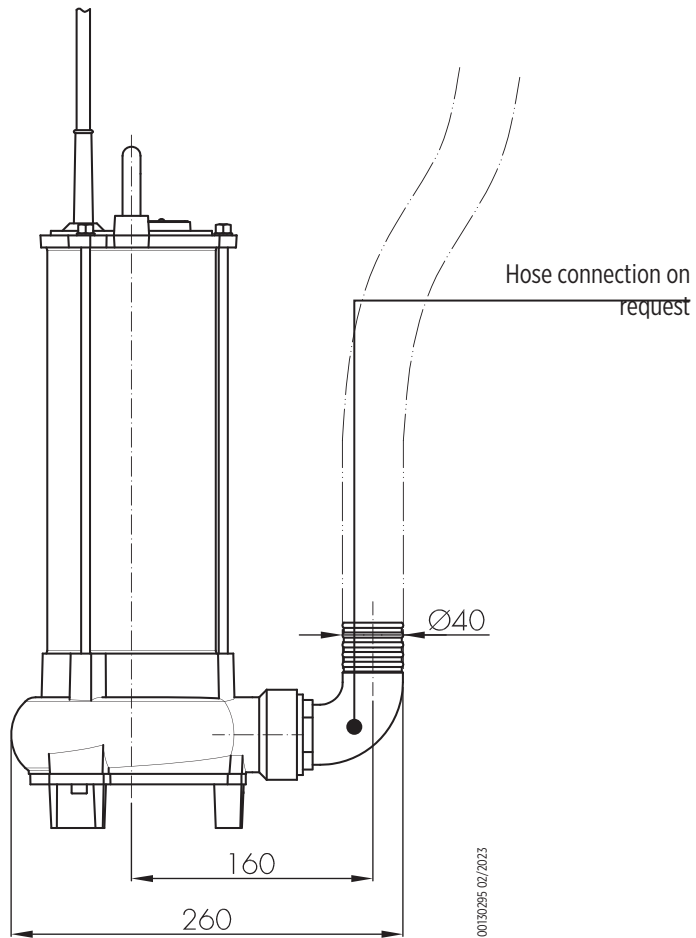

CATALOG REVISION CHANGES NOTICE

Rev. No.	Changes	Page
01	40FGR Technical data correction	84
02	Model correction: from "50FWC-V-54-1,5" to "50FWC-V-54-1,1"	38-42
03	Deleted sentence "Hose connection on request" from 50FWC and 50FGR	30, 36, 42, 92
	40FGR General Features data table correction about power cable single-phase	82
	50FGR General Features data table correction about power cable single-phase	88
	50FWC-V-52-1,6M power cable sigle-phase correction to "4G2,5mm ² , capacitor box and SCHUKO plug (CEE 7/VII)"	38
	50FWC V and 50FWC M Technical data correction from "0,75 HP" to "1,2 HP"	28, 34
	50FGR (50FGR-52-1,1T, 50FGR-52-1,1T-G, 50FGR-52-1,6M, 50FGR-52-1,6M-G) Technical data correction: Motor absorbed Power P1 and Rated Power P2	90
	50FGR Technical data correction - Running capacitor section	90
32FWS V, 40FWS V, 50FWS V General Features motor voltage single-phase correction	8, 14, 20	
04	Added ED-EGT/EGF drainage pump models	5-16
	"EDV Hydraulic Performance 50 Hz ≈ 2900 l/min" section removed	10
	"EGN - Submersible Drainage Pumps for Clean Water" section removed	Tutte
	Updated tables	6, 8, 10, 14, 15, 16
	Pump Identification Code section modified	6
	EGN model removed	All
	EDV model removed	All
	"HH" (High Head version) deleted from FWS-FWC series pump identification code	18
	50FWC V General Features update: voltage single-phase	38
	50FWC M General Features update: voltage single-phase	44
	50FWC V4 General Features update: voltage single-phase	50
	65FWC V4 General Features update: voltage single-phase	68
	50FGR Technical Data table update	102
05	Pump Identification Code section modified	6
	ED General Features update: power cable, motor standard voltage	6
	ED dimensions and weights data table update	8
	ED Hydraulic Performance three-phase data table deleted	10



Franklin Electric

Franklin Electric Europa GmbH
Rudolf-Diesel-Str. 20 - 54516 Wittlich
GERMANY

Phone: +49 (0) 6571 - 105-0
Fax: +49 (0) 6571 - 105-510
Email: info@franklin-electric.de

Franklin Electric S.r.l.
Via Asolo, 7 - 36031 Dueville (Vicenza)
ITALY

Phone: +39 0444 361114
Fax: +39 0444 365247
Email: sales.it@fele.com



10000015088 EN REV.05_12-2023



franklinwater.eu

Single member - Company subject to the control and coordination of Franklin Electric Co., Inc.
Franklin Electric S.r.l. reserves the right to amend specification without prior notice.