

Customer**Supplier**

Company name
Editor
Phone number
E-mail

Fields of Application

Hexa is a kind of multifunctional products. It can be used to convey various medium from tap water to industrial liquid at different temperature and with different flow rate and pressure.

Water supply: Water filter and transport in waterworks, boosting of main pipeline, boosting in high-rise buildings.

Industrial boosting: Process flow water system, cleaning system, high-pressure washing system, fire fighting system.

Industrial liquid conveying: Cooling and air-conditioning system, boiler water supply and condensing system, machine-associated purpose, acids and alkali.

Water treatment: Ultrafiltration system, reverse osmosis system, distillation system, separator, swimming pool.

Irrigation: Farmland irrigation, spray irrigation, dripping irrigation.

**Design Specification**

Hexa is a kind of vertical non-self priming multistage centrifugal pump, which is driven by a standard electric motor. The motor output shaft directly connects with the pump shaft through a coupling. The pressure-resistant cylinder and flow passage components are fixed between pump head and inlet & outlet section with stay bolts. The inlet and outlet are located at the pump bottom at the same plane. This kind of pump can be equipped with an intelligent protector to effectively prevent it from dry-running, out-of-phase and overload.

Operation Conditions

Thin, clean, non-flammable and non-explosive liquid containing no solid, granules and fibers.

Liquid temperature:
Normal temperature type : -15 °C ~ +70 °C
Hot water type : +70 °C ~ +120 °C
Ambient temperature : Up to +40 °C
Altitude : Up to 1000 m
Shaft Seal : Mechanical Seal

Customer
Supplier

Company name
Editor
Phone number
E-mail

Operating data specification

Pumped fluid	Water		Rated flow		m ³ /h
Solids			Rated head		m
Kind			Geodetic head		m
Percentage of solid content	0		Available system NPSH		m
pH value			Inlet pressure (pin)	0	kPa
Temperature	20	°C	Altitude above sea level	100	m
Density	998.3	kg/m ³	Max. operating pressure	844	kPa
Kin. viscosity	1.005	mm ² /s	Max. diff. pressure	844	kPa
Vapour pressure	2.34	kPa			

Pump

Make	MAS DAF		Impeller type		
Pump type	Hexa 16/06		Impeller construction		
Frame size			Impeller Ø		
Design			Max.	111	mm
Self priming	<input checked="" type="checkbox"/> No		designed	111	mm
Speed	2900	1/min	Min.	111	mm
Stages	6		Flow		
Suction port			Nominal	17.4	m ³ /h
Pressure rating	PN25		Max.	22	m ³ /h
Nominal pipe size	DN50		Min.	0	m ³ /h
Standard	DIN		Head		
Discharge port			Nominal	68.3	m
Pressure rating	PN25		Min.	52.2	m
Nominal pipe size	DN50		Max.	86.2	m
Standard	DIN		Shut off head	86.2	m
Shaft power		kW	NPSH3		m
Shaft power P2(Q=max.)	5.23	kW	Efficiency		%

Motor

Make/Type	5.5 KW-2900 RPM / 132S	
Specific design	IE3 / 50 Hz / Pole pairs 1	
Rated power	5.5	kW
Electric voltage	3~ 400	V
Speed	2900	1/min
Electric current	9.8	A
Frame size	132s	
Degree of protection	IP 55	
Type of protection		
Explosion protection		

Coupling

Make/Type	
Series	
Spacer length	mm
Frame size	

Materials

Pump		Shaft seal	VGMG - 1508
Pump Casing	A 276 Type 304 (X5CrNi18.9)	Material code	VZFZF
Base Plate	GJL-250 (GG25)	Secondary Seals	Viton
Casing Flange	GJS-400-15 (GGG40)	Primary Rings	Tungsten Carbide
Impeller	A 276 Type 304 (X5CrNi18.9)	Metal Parts	Stainless Steel
Shaft	A 276 Type 304 (X5CrNi18.9)	Mating	Tungsten Carbide
		Springs	Stainless Steel

Customer

Supplier

Company name
Editor
Phone number
E-mail

Power data referred to: Water; 20°C; 998.3kg/m³; 1.005mm²/s Sense of rotation Clockwise from the drive end

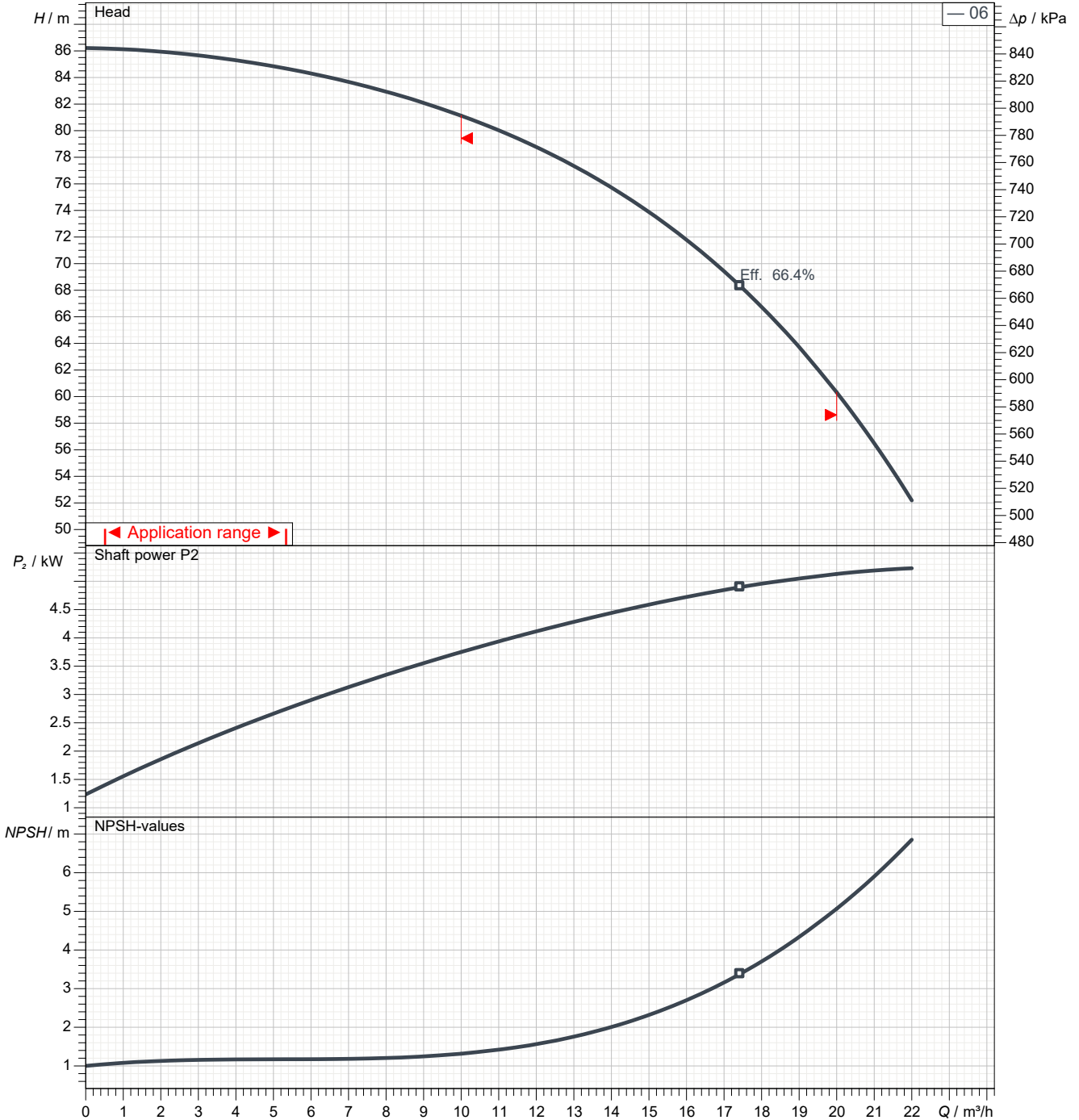

Pump curves in accordance with ISO 9906 2B

Pumped fluid	Water		Rated flow	m ³ /h
Temperature	20	°C	Rated head	m
Density	998.3	kg/m ³	Shaft power	kW
Kin. viscosity	1.005	mm ² /s	Speed	2900 1/min
Vapour pressure	2.34	kPa	NPSH3	m
Impeller Ø	111	mm	Efficiency	%

Subject to change

Projec

Issue date
2024-05-06

Last update
2024-05-06

Customer

Supplier

Company name
Editor
Phone number
E-mail

Performance curves

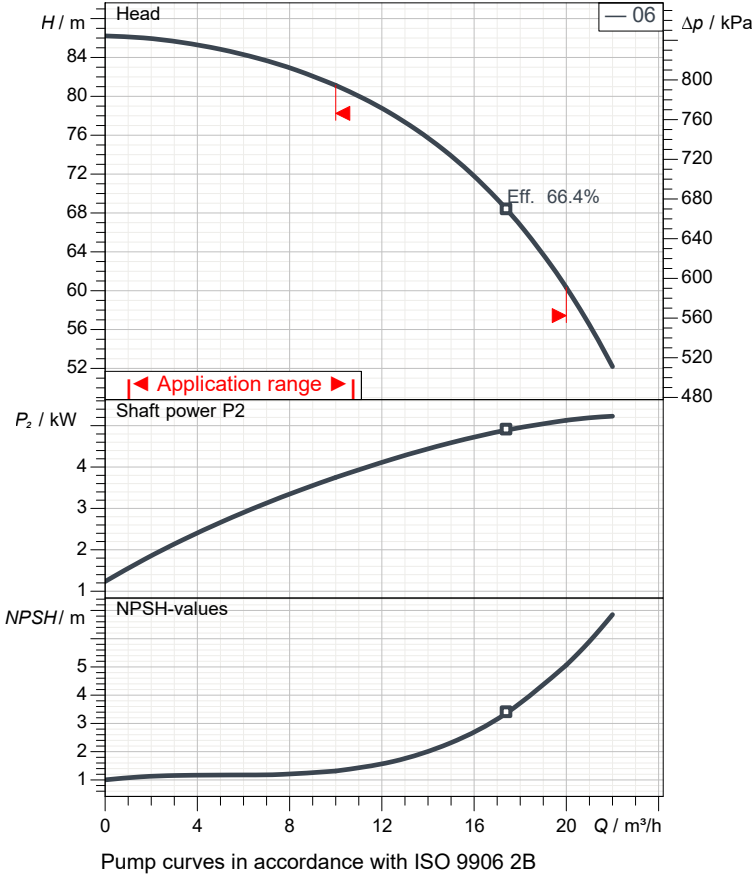

Pump

Make	MAS DAF
Pump type	Hexa 16/06
Design	
Suction port	
Pressure rating	PN25
Nominal pipe size	DN50
Standard	DIN
Discharge port	
Pressure rating	PN25
Nominal pipe size	DN50
Standard	DIN

Operating data specification

Pumped fluid	Water	
Temperature	20	°C
Density	998.3	kg/m ³
Kin. viscosity	1.005	mm ² /s
Vapour pressure	2.34	kPa
Rated flow		m ³ /h
Rated head		m
Shaft power		kW
Speed	2900	1/min
NPSH3		m
Efficiency		%
Impeller Ø	111	mm

Motor

Make/Type	5.5 KW-2900 RPM / 132S
Specific design	IE3 / 50 Hz / Pole pairs 1
Rated power	5.5 kW
Speed	2900 1/min
Electric voltage	3~ 400 V
Electric current	9.8 A
Degree of protection	IP 55

Materials

Shaft seal	VGMG - 1508
Material code	VZFZF
Secondary Seals	Viton
Primary Rings	Tungsten Carbide
Metal Parts	Stainless Steel
Mating	Tungsten Carbide
Springs	Stainless Steel
Pump Casing	A 276 Type 304 (X5CrNi18.9)
Base Plate	GJL-250 (GG25)
Casing Flange	GJS-400-15 (GGG40)
Impeller	A 276 Type 304 (X5CrNi18.9)
Shaft	A 276 Type 304 (X5CrNi18.9)

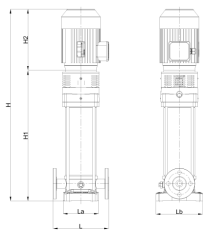

Dimensions

	mm
H	849
H0	243
H1	513
H2	336
L	300
La	200
Lb	250

Customer

Supplier

Company name
Editor
Phone number
E-mail

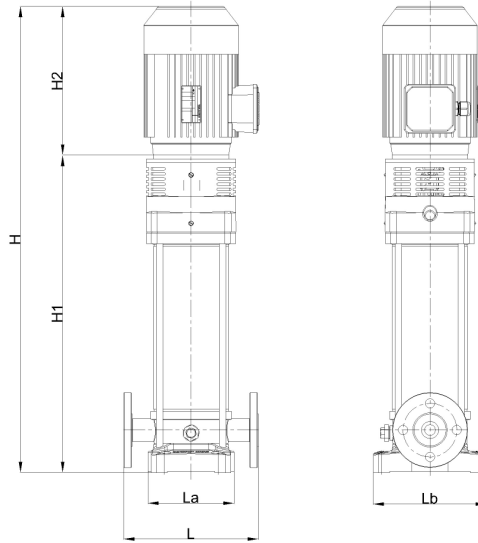

Dimensions	mm
H	849
H0	243
H1	513
H2	336
L	300
La	200
Lb	250

Inlet / outlet	
Suction port	Discharge port
DN50	DN50
PN25	PN25

Customer

Supplier

Company name
Editor
Phone number
E-mail

motor data

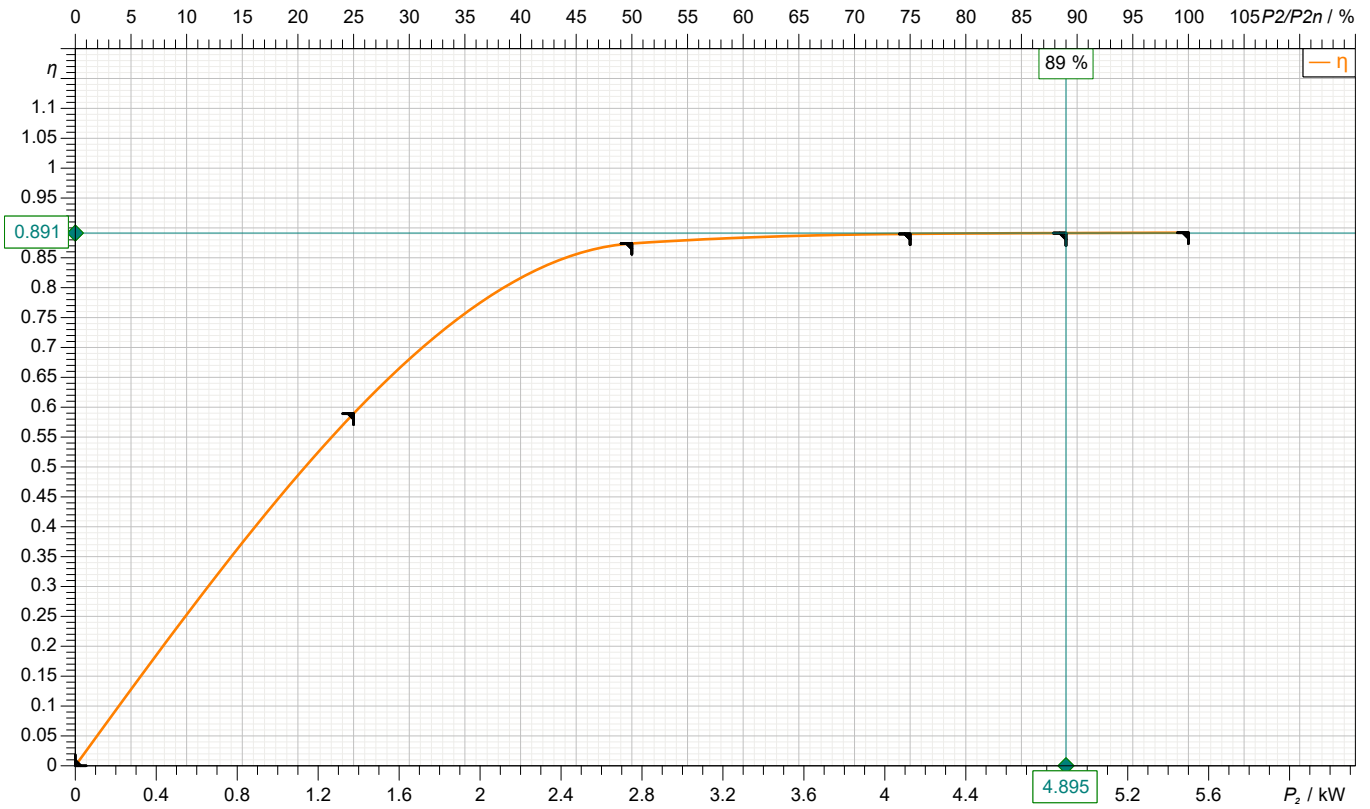

Symbol	No load	25 %	50 %	75 %	100 %	125 %
P_2 / kW	0	1.375	2.75	4.125	5.5	
P_1 / kW		2.333	3.146	4.635	6.166	
η / %	0	58.93	87.4	89	89.2	

Motor

Make/Type	5.5 KW-2900 RPM / 132S	Degree of protection	IP 55
Specific design	IE3 / 50 Hz / Pole pairs 1	Type of protection	
Rated power	5.5 kW	Explosion protection	
Electric voltage	3~ 400 V	Service factor	1.15
Number of poles	2	Starting current	
Speed	2900 1/min	Starting torque	
Electric current	9.8 A	Moment of inertia	
Power factor	0.91	No. starts per hour	
Frame size	132s	Rated torque	18.1 Nm
Efficiency class	IE3	Insulation class	F (155C°)

Customer

Supplier

Company name
Editor
Phone number
E-mail

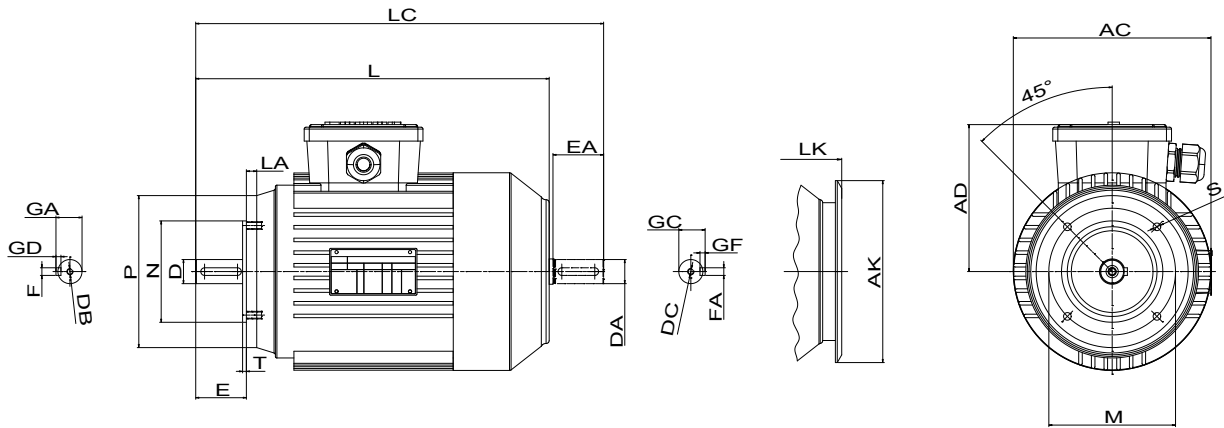

Dimensions	mm		
AC	257	LC	584
AD	168	LK	535
AK	239	M	215
D	38	N	180
DA	38	P	250
DB	M12	S	M12
DC	M12	T	4
E	80		
EA	80		
FxGF	10X8		
FxGD	10X8		
GA	41		
GC	41		
L	498		
LA	18		

Customer

Supplier

Company name
Editor
Phone number
E-mail

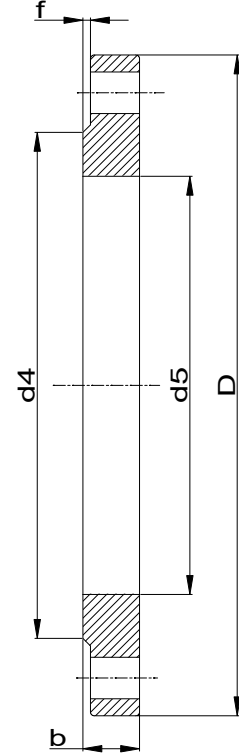
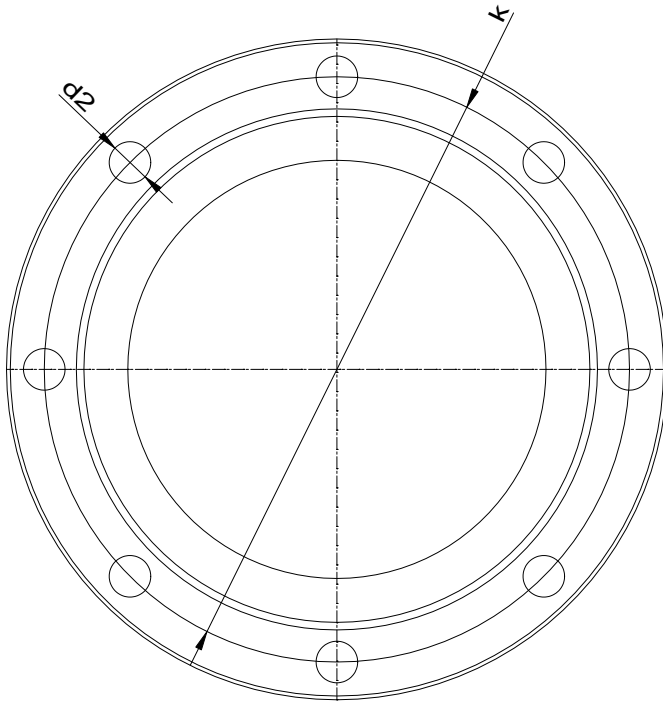

Suction connection

DN50
PN25

Discharge connection

DN50
PN25

Dimensions	mm
b	20
D	165
d2	18
d4	102
d5	61.5
DN	50
f	2
k	125
n	4

Dimensions	mm
b	20
D	165
d2	18
d4	102
d5	61.5
DN	50
f	2
k	125
n	4



Spare part list

Hexa 16/06

Revision number

Page

9

Customer

Supplier

Company name
Editor
Phone number
E-mail

Subject to change

Projec

Issue date
2024-05-06

Last update
2024-05-06



Spare part list

Hexa 16/06

Revision number

Page
10

Company name
Editor
Phone number
E-mail

Customer

Supplier

Subject to change

Projec

Issue date
2024-05-06

Last update
2024-05-06